

# CLA-VAL

**AUTOMATIC CONTROL VALVES**

**50B-4KG1/2050B-4KG1**

Place this manual with personal responsible  
for maintenance of this valve

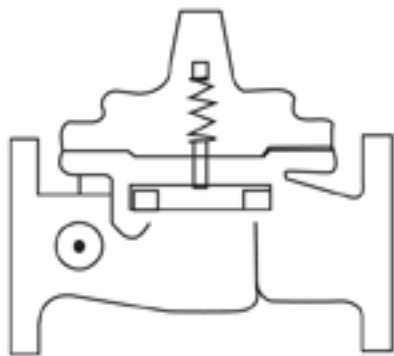

## ***INSTALLATION***

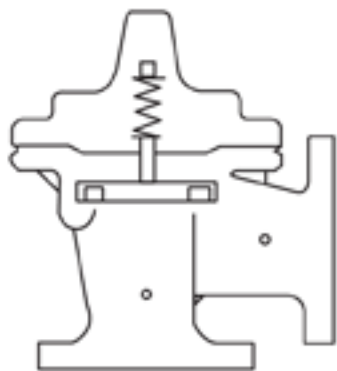

## ***OPERATION***

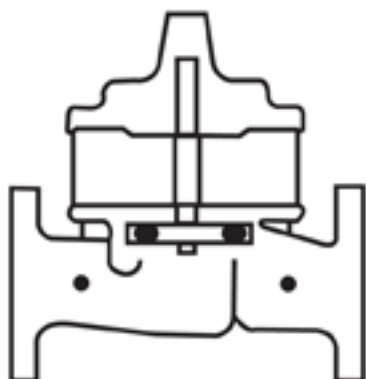

## ***MAINTENANCE***





NEWPORT BEACH, CALIFORNIA

CATALOG NO.  
50B-4KG1 (GLOBE)  
2050B-4KG1 (ANGLE)

DRAWING NO.  
80984

REV.  
R

TYPE OF VALVE AND MAIN FEATURES **PRESSURE RELIEF VALVE**  
THIS VALVE IS FACTORY MUTUAL APPROVED, FM SERIAL NO. 21102,  
DATED MAY 12, 1972, & OM6A5. AH DATED OCT. 10, 1985 FOR SIZES  
4", 6" & 8", (REF. E50B-4KG1) U.L. LISTED SIZES 3", 4" & 6".

DESIGN		
DRAW	MGR	8-18-80
CHK'D	CH	8-20-80
APVD	HWE	8-20-80

----- NOT FURNISHED BY CLA-VAL CO. ----- OPTIONAL FEATURES

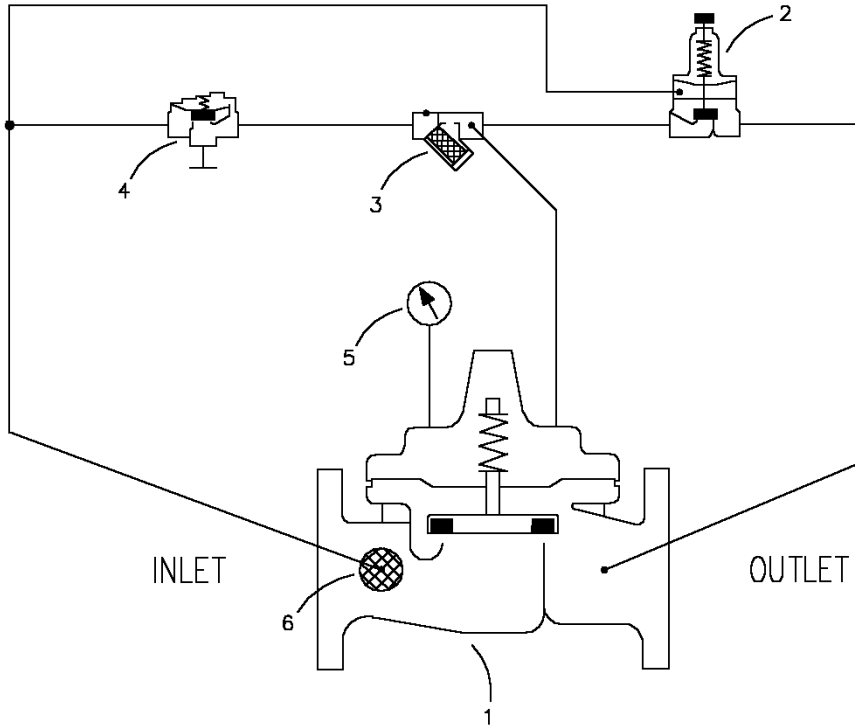

- \* FORMERLY 100HGK
- \*\* UL LISTING CRL  
RANGE 20-200 PSI  
100-300 PSI  
FM APPROVED CRL  
RANGE 20-200 PSI

NOTE: FACTORY MUTUAL APPROVAL  
NO. 21102 IS FOR SPLIT CASE PUMPS  
AND APPROVAL NO. OM6A5.AH IS FOR  
VERTICAL TURBINE PUMPS

ITEM NO.	BASIC COMPONENTS	QTY
1	*100-06 HYTROL (MAIN VALVE)	1
2	**CRL PRESSURE RELIEF CONTROL	1
3	X44A STRAINER & ORIFICE ASSEMBLY	1
4	B1-01 CHECK VALVE	1
5	PRESSURE GAGE	1
6	X46A FLOW CLEAN STRAINER	1

OPTIONAL FEATURE SUFFIX	ADDED TO CATALOG NUMBER

CAD REVISION RECORD - DO NOT REVISE MANUALLY  
 DESCRIPTION  
 BY DATE  
 A-M SEE REVISION FILE  
 N ADDED NOTE ON PRESSURE RELIEF FEATURE & REDRAWN ON CAD (ECO 11855)  
 TLC 10-17-91  
 P ADDED \*\*NOTE TO ITEM 2 & "(6)" TO OPERATING DATA NOTE 1 (ECO 13677)  
 R REMOVED 100-19 FROM ITEM 1 & REF. FOR "OLD STYLE COVER". (ECO 16491)  
 JLB 2-27-97  
 TLC 4-21-93

THIS DRAWING IS THE PROPERTY OF CLA-VAL CO. AND SAME AND COPIES MADE THEREOF, IF ANY, SHALL BE RETURNED TO IT UPON DEMAND. DELIVERY AND DISCLOSURE HEREOF ARE SOLELY UPON CONDITION THAT THE SAME SHALL NOT BE USED, COPIED OR REPRODUCED, NOR SHALL THE SUBJECT HEREOF BE DISCLOSED IN ANY MANNER TO ANYONE FOR ANY PURPOSE, EXCEPT AS HEREIN AUTHORIZED, WITHOUT PRIOR WRITTEN APPROVAL OF CLA-VAL CO. THIS DRAWING IS SUBMITTED CONFIDENTIALLY AND MAY NOT BE USED IN THE MANUFACTURE OF ANY MATERIAL OR PRODUCT OTHER THAN SUCH MATERIALS AND PRODUCTS FURNISHED TO CLA-VAL CO. WHETHER OR NOT THE EQUIPMENT OR INFORMATION SHOWN HEREON IS PATENTED OR OTHERWISE PROTECTED, FULL TITLE AND COPYRIGHTS, IF ANY, IN AND TO THIS DRAWING AND/OR INFORMATION DELIVERED OR SUBMITTED ARE FULLY RESERVED CLA-VAL CO.®



NEWPORT BEACH, CALIFORNIA

CATALOG NO.  
50B-4KG1 (GLOBE)  
2050B-4KG1 (ANGLE)

DRAWING NO.  
80984

REV.  
R

**TYPE OF VALVE AND MAIN FEATURES** PRESSURE RELIEF VALVE  
THIS VALVE IS FACTORY MUTUAL APPROVED, FM SERIAL NO. 21102,  
DATED MAY 12, 1972, & OM6A5. AH DATED OCT. 10, 1985 FOR SIZES  
4", 6" & 8", (REF. E50B-4KG1) U.L. LISTED SIZES 3", 4" & 6".

DESIGN		
DRAW	JM	8-3-71
CHK'D	JM	2-29-72
APVD	JM	2-29-72

OPERATING DATA

I. DESCRIPTION

THE CLAYTON 50B-4KG1 AND 2050B-4KG1 PRESSURE RELIEF VALVES ARE DIAPHRAGM ACTUATED PILOT CONTROLLED VALVES DESIGNED TO MAINTAIN A RELATIVELY CONSTANT PRESSURE AT THE MAIN VALVE INLET. THE PRESSURE RELIEF SET POINT IS EASILY ADJUSTED WITHIN THE RANGE SHOWN ON THE PRESSURE RELIEF CONTROL NAMEPLATE.

II. PRESSURE RELIEF FEATURE

PRESSURE RELIEF CONTROL (2) IS A SPRING LOADED, NORMALLY CLOSED PILOT CONTROL THAT RESPONDS TO SLIGHT PRESSURE CHANGES AT MAIN VALVE INLET. AN INCREASE IN INLET PRESSURE TENDS TO OPEN CONTROL (2) AND A DECREASE IN INLET PRESSURE TENDS TO CLOSE CONTROL (2). THIS CAUSES MAIN VALVE COVER PRESSURE TO VARY AND THE MAIN VALVE MODULATES (OPENS AND CLOSES) MAINTAINING A RELATIVELY CONSTANT PRESSURE AT THE MAIN VALVE INLET. A BRIEF EXPLANATION OF THE OPENING AND CLOSING CYCLE IS AS FOLLOWING:

OPENING CYCLE:

- (a) INLET PRESSURE IS DIRECTED THROUGH THE SENSING LINE TO THE ACTUATING DIAPHRAGM OF CONTROL (2).
- (b) WHEN FORCE CREATED BY INLET PRESSURE UNDER DIAPHRAGM OF CONTROL (2) EXCEEDS THE FORCE OF THE SPRING IN CONTROL (2), CONTROL (2) OPENS.
- (c) WHEN FLOW OUT OF MAIN VALVE COVER CHAMBER THROUGH CONTROL (2) EXCEEDS FLOW INTO THE MAIN VALVE COVER CHAMBER THROUGH STRAINER & ORIFICE (3), PRESSURE IN THE MAIN VALVE COVER CHAMBER IS REDUCED.
- (d) WITH REDUCED PRESSURE IN THE MAIN VALVE COVER CHAMBER AND FULL INLET PRESSURE UNDER THE MAIN VALVE DISC, THE MAIN VALVE OPENS.

CLOSING CYCLE:

- (a) WHEN FORCE CREATED BY INLET PRESSURE UNDER DIAPHRAGM OF CONTROL (2) IS LESS THE FORCE OF THE SPRING IN CONTROL (2), CONTROL (2) CLOSES.
- (b) THE MAIN VALVE COVER CHAMBER IS SLOWLY PRESSURIZED THROUGH STRAINER & ORIFICE (3) AND THE MAIN VALVE CLOSES.

III. PRESSURE RELIEF CONTROL (2) ADJUSTMENT

- (a) REMOVE PLASTIC CAP. (TURN COUNTERCLOCKWISE)
- (b) LOOSEN ADJUSTING SCREW JAM NUT. (TURN COUNTERCLOCKWISE)
- (c) TURN ADJUSTING SCREW CLOCKWISE TO INCREASE PRESSURE RELIEF SET POINT. (OR COUNTERCLOCKWISE TO DECREASE SET POINT.)
- (d) RE-TIGHTEN JAM NUT.
- (e) REPLACE PLASTIC CAP.

IV. CHECK VALVE FEATURE:

WHEN COVER PRESSURE IS HIGHER THAN INLET PRESSURE, CHECK VALVE (4) CLOSES. THIS MAINTAINS THE HIGHER PRESSURE IN THE MAIN VALVE COVER CHAMBER KEEPING THE MAIN VALVE CLOSED.

NOTES:

- 1. PERIODIC CLEANING OF STRAINER SCREEN IN ITEM (3) & (6) IS RECOMMENDED.
- 2. RELIEF VALVE (2) SHOULD BE TESTED AFTER INSTALLATION TO VERIFY SETTING.

CAD REVISION RECORD - DO NOT REVISE MANUALLY  
DATE  
BY  
DESCRIPTION  
SEE SHEET 1  
LTR

THIS DRAWING IS THE PROPERTY OF CLA-VAL CO. AND SAME AND COPIES MADE THEREOF, IF ANY, SHALL BE RETURNED TO IT UPON DEMAND. DELIVERY AND DISCLOSURE HEREOF ARE SOLELY UPON CONDITION THAT THE SAME SHALL NOT BE USED, COPIED OR REPRODUCED, NOR SHALL THE SUBJECT HEREOF BE DISCLOSED IN ANY MANNER TO ANYONE FOR ANY PURPOSE, EXCEPT AS HEREIN AUTHORIZED, WITHOUT PRIOR WRITTEN APPROVAL OF CLA-VAL CO. THIS DRAWING IS SUBMITTED CONFIDENTIALLY AND MAY NOT BE USED IN THE MANUFACTURE OF ANY MATERIAL OR PRODUCT OTHER THAN SUCH MATERIALS AND PRODUCTS FURNISHED TO CLA-VAL CO. WHETHER OR NOT THE EQUIPMENT OR INFORMATION SHOWN HEREON IS PATENTED OR OTHERWISE PROTECTED, FULL TITLE AND COPYRIGHTS, IF ANY, IN AND TO THIS DRAWING AND/OR INFORMATION DELIVERED OR SUBMITTED ARE FULLY RESERVED CLA-VAL CO.®



— MODEL — **50B-4KG-1**

# Fire Protection Pressure Relief Valve



2050B-4KG1 (Angle)

- **U.L. Listed / U.L.C. Listed**
- **Factory Mutual Approved**
- **Fast Opening to Maintain Steady Line Pressure**
- **Accommodates Wide Range of Flow Rates**
- **Closes Gradually for Surge-Free Operation**
- **Adjustable Pressure Settings, Not Affected by Pressure At Valve Discharge**

The Cla-Val Model 50B-4KG-1 Globe / 2050B-4KG Angle Pressure Relief Valve is designed specifically to automatically relieve excess pressure in fire protection pumping systems. Pilot controlled, it maintains constant system pressure at the pump discharge within very close limits as demands change.

**U.L. Listed.....Sizes 3" thru 8"**  
**F.M. Approved.....Sizes 3" thru 8"**  
**U.L.C. Listed.....Sizes 2" thru 10"**

## Typical Application

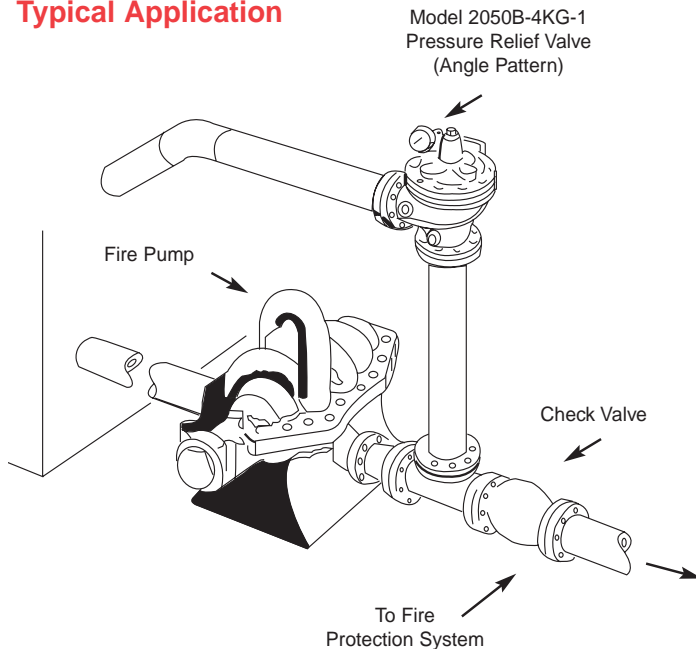

## Operation Sequence

At pump start, Cla-Val Relief Valve modulates to relieve excess pump capacity, maintaining positive system pressure at the pump discharge.

When fire demand slows or ceases, Cla-Val Model 50B-4KG-1 opens, diverting entire pump output to discharge, allowing fire pump to be stopped without causing surging in the lines.

(Please note that if the Model 50B-4KG-1 is to be used on a continuous duty basis to maintain fire-system pressure, suitable back pressure must be provided on the valve to prevent cavitation damage. Consult the factory for details.)

**"Fluid Control at It's Best"**



## Specifications

**Sizes** Globe: 2" - 12" flanged  
Angle: 2" - 12" flanged

**End Details** 150 and 300 ANSI B16.42

**Pressure Ratings** class - 175 psi Max.  
class - 300 psi Max.  
Water, to 180°F Max.

**Materials** **Main Valve Body & Cover**  
Ductile Iron ASTM A-536  
Naval Bronze ASTM B61  
Other Material Available  
**Standard Main Valve Trim:**  
Bronze Seat, Teflon Coated  
Stainless Steel Stem, Delrin Sleeved  
**Standard Pilot Control System:**  
Cast Bronze with  
Stainless Steel trim

**Adjustment Range** Available in the following relief pressure ranges:  
20-200 psi (150 Class)  
100-300 psi (300 Class)

**Optional** Protective epoxy resin coating of wetted surfaces of main valve cast iron components (UL listed HNFx EX2855)

## Purchase Specifications

The Fire Pump Pressure Relief Valve shall modulate to relieve excess pressure in a fire protection system. It shall maintain constant pressure in the system regardless of demand changes. It shall be pilot controlled and back pressure shall not affect its set point. It shall be actuated by line pressure through a pilot control system and open fast in order to maintain steady system pressure as system demand decreases. It shall close gradually to control surges and shall re-seat drip-tight within 5% of its pressure setting. The main valve shall be of the hydraulically-operated, pilot-controlled, diaphragm-type, globe or angle valve. It shall have a single, removable, teflon-coated seat, a grooved stem guided at both ends, and a resilient disc with a rectangular cross section, being contained on 3 1/2 sides. No external packing glands shall be permitted and the diaphragm shall not be used as a seating surface. The pilot control shall be a direct-acting, adjustable, spring-loaded, diaphragm-type valve designed for modulating service to permit flow when controlling pressure exceeds spring setting. This valve shall be UL Listed and Factory Mutual approved. It shall be the Model 50B-4KG-1 (globe) or Model 2050B-4KG-1 (angle) Pressure Relief Valve as manufactured by Cla-Val Newport Beach, California.

### \*Special Note:

The Model 50B-4KG-1 Pressure Relief Valve is available with 300# ANSI inlet flange and 150# ANSI outlet flange. This valve is used on higher pressure systems where 300# flange connections are required, and allows for adapting of a discharge cone (generally supplied with 150# flange) to accommodate "atmospheric break" at relief valve discharge. This relief valve, with 300# / 150# flanges is available on special order, and is UNDERWRITERS LABORATORIES LISTED AND FACTORY MUTUAL APPROVED.

## Specifications Seawater Service Option

**Sizes** Globe: 2" - 10" flanged  
Angle: 2" - 10" flanged

Consult factory for materials and flange ratings.

## Dimensions

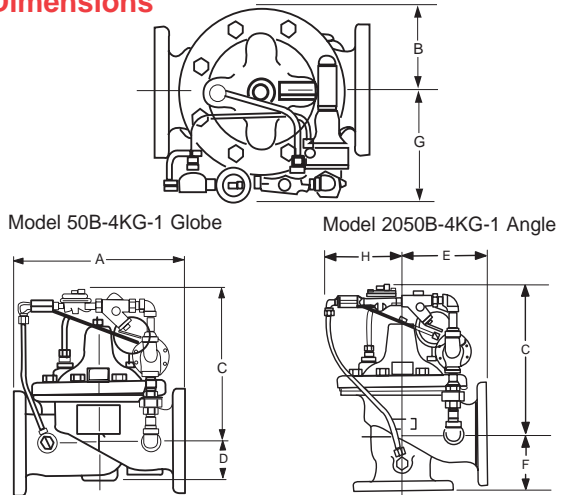

We recommend providing adequate space around valve for maintenance work.

Valve Size (inches)	2"	2 1/2"	3"	4"	6"	8"	10"	12"
<b>Threaded Ends</b>	9.38	11.00	12.50	--	--	--	--	--
<b>A 150 Flanged</b>	9.38	11.00	12.00	15.00	20.00	25.38	29.75	34.00
300 Flanged	10.00	11.62	13.25	15.62	21.00	26.38	31.12	35.50
300 x 150			12.88	15.31	20.56	25.88	30.44	34.75
<b>B</b>	3.31	4.00	4.56	5.75	7.88	10.00	11.81	14.00
<b>C</b>	12.00	12.25	12.50	13.00	14.31	16.31	18.00	20.56
<b>D</b>	1.50	1.69	2.56	3.19	4.31	5.31	9.25	10.75
<b>Threaded Ends</b>	4.75	5.60	6.25	--	--	--	--	--
<b>E 150 Flanged</b>	4.75	5.50	6.00	7.50	10.00	12.75	14.88	17.00
300 Flanged	5.00	5.88	6.38	7.88	10.50	13.25	15.56	17.75
<b>Screwed Ends</b>	3.25	4.00	4.50	--	--	--	--	--
<b>F 150 Flanged</b>	3.25	4.00	4.00	5.00	6.00	8.00	8.62	13.75
300 Flanged	3.50	4.31	4.38	5.31	6.50	8.50	9.31	14.50
<b>G &amp; H</b>	6.00	6.69	7.75	7.88	8.50	9.75	13.25	14.25

Valve Size (mm)	50	65	80	100	150	200	250	300
<b>Threaded Ends</b>	238	279	318	--	--	--	--	--
<b>A 150 Flanged</b>	238	279	305	381	508	645	756	864
300 Flanged	254	295	337	397	533	670	790	902
300 x 150	--	--	327	389	522	657	773	883
<b>B</b>	84	102	116	146	200	254	300	356
<b>C</b>	305	311	318	330	363	414	457	522
<b>D</b>	38	43	65	81	109	135	235	273
<b>Threaded Ends</b>	121	140	159	--	--	--	--	--
<b>E 150 Flanged</b>	121	140	152	191	254	324	378	432
300 Flanged	127	149	162	200	267	337	395	451
<b>Threaded Ends</b>	83	102	114	--	--	--	--	--
<b>F 150 Flanged</b>	83	102	102	127	152	203	219	349
300 Flanged	89	109	111	135	165	216	236	368
<b>G &amp; H</b>	152	170	197	200	216	248	337	362

## Valve Capacity

Valve Sizes in Inches: 2" 2 1/2" 3" 4" 6" 8" 10" 12"

NFPA 20 Maximum Recommended GPM 208 300 500 1000 2500 5000 11000 16000



E-50B-4KG-1 (R-7/04)

## CLA-VAL

PO Box 1325 Newport Beach CA 92659-0325 • Phone: 949-722-4800  
Fax: 949-548-5441 • Web Site: cla-val.com • E-mail: cla-val@cla-val.com

**CLA-VAL CANADA**  
4687 Christie Drive  
Beamsville, Ontario  
Canada L0R 1B4  
Phone: 905-563-4963  
Fax: 905-563-4040  
E-Mail: sales@cla-val.ca

**CLA-VAL EUROPE**  
Chemin des M sanges 1  
CH-1032 Romanel/  
Lausanne, Switzerland  
Phone: 41-21-643-15-55  
Fax: 41-21-643-15-50  
E-Mail: cla-val@cla-val.ch

**CLA-VAL UK**  
Dainton House, Goods Station Road  
GB - Tunbridge Wells  
Kent TN11 2 DH England  
Phone: 44-1892-514-400  
Fax: 44-1892-543-423  
E-Mail: info@cla-val.co.uk

## Represented By:





—MODEL— **100-01**  
**Hytrol Valve**

**Description**

The Cla-Val Model 100-01 Hytrol Valve is a main valve for Cla-Val Automatic Control Valves. It is a hydraulically operated, diaphragm-actuated, globe or angle pattern valve.

This valve consists of three major components; body, diaphragm assembly, and cover. The diaphragm assembly is the only moving part. The diaphragm assembly uses a diaphragm of nylon fabric bonded with synthetic rubber. A synthetic rubber disc, contained on three and one half sides by a disc retainer and disc guide, forms a seal with the valve seat when pressure is applied above the diaphragm. The diaphragm assembly forms a sealed chamber in the upper portion of the valve, separating operating pressure from line pressure.

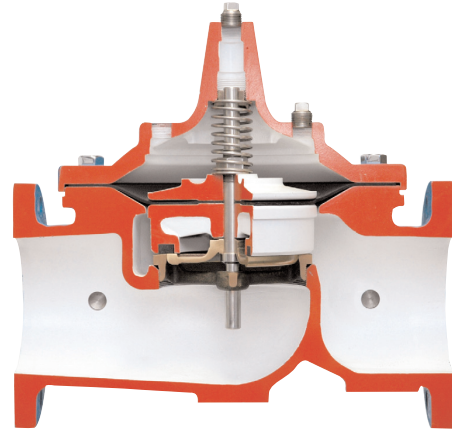

**Installation**

1. Before valve is installed, pipe lines should be flushed of all chips, scale and foreign matter.
2. It is recommended that either gate or block valves be installed on both ends of the 100-01 Hytrol Valve to facilitate isolating the valve for preventive maintenance and repairs.
3. Place the valve in the line with flow through the valve in the direction indicated on the inlet nameplate. (See "Flow Direction" Section)
4. Allow sufficient room around valve to make adjustments and for disassembly.
5. Cla-Val 100-01 Hytrol Valves operate with maximum efficiency when mounted in horizontal piping with the cover UP, however,

- other positions are acceptable. Due to size and weight of the cover and internal components of 8 inch and larger valves, installation with the cover UP is advisable. This makes internal parts readily accessible for periodic inspection.
6. If a pilot control system is installed on the 100-01 Hytrol Valve, use care to prevent damage. If it is necessary to remove fittings or components, be sure they are kept clean and replaced exactly as they were.
7. After the valve is installed and the system is first pressurized, vent air from the cover chamber and pilot system tubing by loosening fittings at all high points.

**Principles of Operation**

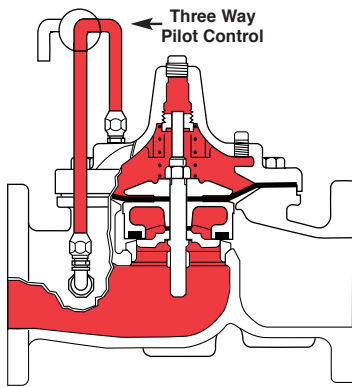

**Tight Closing Operation**

When pressure from the valve inlet (or an equivalent independent operating pressure) is applied to the diaphragm chamber the valve closes drip-tight.

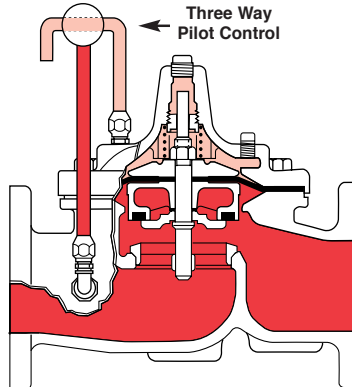

**Full Open Operation**

When pressure in diaphragm chamber is relieved to a zone of lower pressure (usually atmosphere) the line pressure (5 psi Min.) at the valve inlet opens the valve.

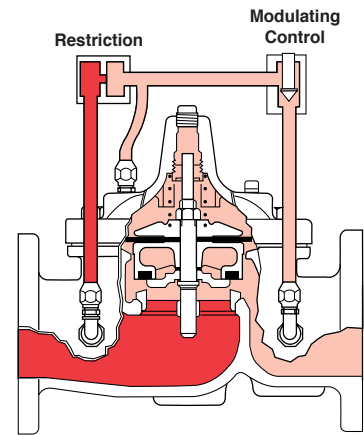

**Modulating Action**

Valve modulates when diaphragm pressure is held at an intermediate point between inlet and discharge pressure. With the use of a Cla-Val. "modulating control," which reacts to line pressure changes, the pressure above the diaphragm is varied, allowing the valve to throttle and compensate for the change.

## Flow Direction

The flow through the 100-01 Hytrol Valve can be in one of two directions. When flow is “up-and-over the seat,” it is in “normal” flow and the valve will fail in the open position. When flow is “over-the seat-and down,” it is in “reverse” flow and the valve will fail in the closed position. There are no permanent flow arrow markings.

**The valve must be installed according to nameplate data.**

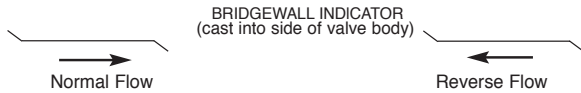

## Recommended Tools

1. Three pressure gauges with ranges suitable to the installation to be put at Hytrol inlet, outlet and cover connections.
2. Cla-Val Model X101 Valve Position Indicator. This provides visual indication of valve position without disassembly of valve.
3. Other items are: suitable hand tools such as screwdrivers, wrenches, etc. soft jawed (brass or aluminum) vise, 400 grit wet or dry sandpaper and water for cleaning.

## Troubleshooting

The following troubleshooting information deals strictly with the Model 100-01 Hytrol Valve. This assumes that all other components of the pilot control system have been checked out and are in proper working condition. (See appropriate sections in Technical Manual for complete valve).

All trouble shooting is possible without removing the valve from the line or removing the cover. It is highly recommended to permanently install a Model X101 Valve Position Indicator and three gauges in unused Hytrol inlet, outlet and cover connections.

SYMPTOM	PROBABLE CAUSE	REMEDY
Fails to Close	Closed isolation valves in control system, or in main line.	Open Isolation valves.
	Lack of cover chamber pressure.	Check upstream pressure, pilot system, strainer, tubing, valves, or needle valves for obstruction.
	Diaphragm damaged. (See Diaphragm Check.)	Replace diaphragm.
	Diaphragm assembly inoperative. Corrosion or excessive scale build up on valve stem. (See Freedom of Movement Check)	Clean and polish stem. Inspect and replace any damaged or badly eroded part.
	Mechanical obstruction. Object lodged in valve. (See Freedom of Movement Check)	Remove obstruction.
	Worn disc. (See Tight Sealing Check)	Replace disc.
	Badly scored seat. (See Tight Sealing Check)	Replace seat.
Fails to Open	Closed upstream and/or downstream isolation valves in main line.	Open isolation valves.
	Insufficient line pressure.	Check upstream pressure. (Minimum 5 psi flowing line pressure differential.)
	Diaphragm assembly inoperative. Corrosion or excessive buildup on valve stem. (See Freedom of Movement Check)	Clean and polish stem. Inspect and replace any damaged or badly eroded part.
	Diaphragm damaged. (For valves in "reverse flow" only)	Replace diaphragm.

**After checking out probable causes and remedies, the following three checks can be used to diagnose the nature of the problem before maintenance is started. They must be done in the order shown.**

### Three Checks

The 100-01 Hytrol Valve has only one moving part (the diaphragm and disc assembly). So, there are only three major types of problems to be considered.

**First:** Valve is stuck - that is, the diaphragm assembly is not free to move through a full stroke either from open to close or vice versa.

**Second:** Valve is free to move and can't close because of a worn out diaphragm.

**Third:** Valve leaks even though it is free to move and the diaphragm isn't leaking.

#### **CAUTION:**

*Care should be taken when doing the troubleshooting checks on the 100-01 Hytrol Valve. These checks do require the valve to open fully. This will either allow a high flow rate through the valve, or the downstream pressure will quickly increase to the inlet pressure. In some cases, this can be very harmful. Where this is the case, and there are no block valves in the system to protect the downstream piping, it should be realized that **the valve cannot be serviced under pressure.** Steps should be taken to remedy this situation before proceeding any further.*

## Diaphragm Check (#1)

1. Shut off pressure to the Hytrol Valve by slowly closing upstream and downstream isolation valves. **SEE CAUTION.**
2. Disconnect or close all pilot control lines to the valve cover and leave only one fitting in highest point of cover open to atmosphere.
3. With the cover vented to atmosphere, slowly open upstream isolation valve to allow some pressure into the Hytrol Valve body. Observe the open cover tapping for signs of continuous flow. It is not necessary to fully open isolating valve. Volume in cover chamber capacity chart will be displaced as valve moves to open position. Allow sufficient time for diaphragm assembly to shift positions. If there is no continuous flow, you can be quite certain the diaphragm is sound and the diaphragm assembly is tight. If the fluid appears to flow continuously this is a good reason to believe the diaphragm is either damaged or it is loose on the stem. In either case, this is sufficient cause to remove the valve cover and investigate the leakage. (See "Maintenance" Section for procedure.)

### COVER CHAMBER CAPACITY (Liquid Volume displaced when valve opens)

Valve size (inches)	Displacement	
	Gallons	Liters
1 1/4	.020	.07
1 1/2	.020	.07
2	.032	.12
2 1/2	.043	.16
3	.080	.30
4	.169	.64
6	.531	2.0
8	1.26	4.8
10	2.51	9.5
12	4.00	15.1
14	6.50	24.6
16	9.57	36.2
24	29.00	109.8
36	42.00	159.0

## Freedom of Movement Check (#2)

4. Determining the Hytrol Valve's freedom of movement can be done by one of two methods.
5. For most valves it can be done after completing Diaphragm Check (Steps 1, 2, and 3). **SEE CAUTION.** At the end of step 3 the valve should be fully open.
6. If the valve has a Cla-Val X101 Position Indicator, observe the indicator to see that the valve opens wide. Mark the point of maximum opening.
7. Re-connect enough of the control system to permit the application of inlet pressure to the cover. Open pilot system cock so pressure flows from the inlet into the cover.
8. While pressure is building up in the cover, the valve should close smoothly. There is a hesitation in every Hytrol Valve closure, which can be mistaken for a mechanical bind. The stem will appear to stop moving very briefly before going to the closed position. This slight pause is caused by the diaphragm flexing at a particular point in the valve's travel and is not caused by a mechanical bind.
9. When closed, a mark should be made on the X101 Valve position indicator corresponding to the "closed" position. The distance between the two marks should be approximately the stem travel shown in chart.

## STEM TRAVEL

(Fully Open to Fully Closed)

Valve Size (inches)		Travel (inches)	
Inches	MM	Inches	MM
1 1/4	32	0.4	10
1 1/2	40	0.4	10
2	50	0.6	15
2 1/2	65	0.7	18
3	80	0.8	20
4	100	1.1	28
6	150	1.7	43
8	200	2.3	58
10	250	2.8	71
12	300	3.4	86
14	350	4.0	100
16	400	4.5	114
24	600	6.5	165
36	900	8.5	216

10. If the stroke is different than that shown in stem travel chart this is a good reason to believe something is mechanically restricting the stroke of the valve at one end of its travel. If the flow does not stop through the valve when in the indicated "closed" position, the obstruction probably is between the disc and the seat. If the flow does stop, then the obstruction is more likely in the cover. In either case, the cover must be removed, and the obstruction located and removed. The stem should also be checked for scale build-up. (See "Maintenance, section for procedure.)

11. For valves 6" and smaller, the Hytrol Valve's freedom of movement check can also be done after all pressure is removed from the valve. **SEE CAUTION.** After closing inlet and outlet isolation valves and bleeding pressure from the valve, check that the cover chamber and the body are temporarily vented to atmosphere. Insert fabricated tool into threaded hole in top of valve stem, and lift the diaphragm assembly manually. Note any roughness. The diaphragm assembly should move smoothly throughout entire valve stroke. The tool is fabricated from rod that is threaded on one end to fit valve stem and has a "T" bar handle of some kind on the other end for easy gripping. (See chart in Step 4 of "Disassembly" Section.)

12. Place marks on this diaphragm assembly lifting tool when the valve is closed and when manually positioned open. The distance between the two marks should be approximately the stem travel shown in stem travel chart. If the stroke is different than that shown, there is a good reason to believe something is mechanically restricting the stroke of the valve. The cover must be removed, and the obstruction located and removed. The stem should also be checked for scale build-up. (See "Maintenance" Section for procedure.)

## Tight Sealing Check (#3)

13. Test for seat leakage after completing checks #1 & #2 (Steps 1 to 12). **SEE CAUTION.** Close the isolation valve downstream of the Hytrol Valve. Apply inlet pressure to the cover of the valve, wait until it closes. Install a pressure gauge between the two closed valves using one of the two ports in the outlet side of the Hytrol. Watch the pressure gauge. If the pressure begins to climb, then either the downstream isolation valve is permitting pressure to creep back, or the Hytrol is allowing pressure to go through it. Usually the pressure at the Hytrol inlet will be higher than on the isolation valve discharge, so if the pressure goes up to the inlet pressure, you can be sure the Hytrol is leaking. Install another gauge downstream of isolating valve. If the pressure between the valves only goes up to the pressure on the isolation valve discharge, the Hytrol Valve is holding tight, and it was just the isolation valve leaking.

## Maintenance

### Preventative Maintenance

The Cla-Val Co. Model 100-01 Hytrol Valve requires no lubrication or packing and a minimum of maintenance. However, a periodic inspection schedule should be established to determine how the operating conditions of the system are affecting the valve. The effect of these actions must be determined by inspection.

### Disassembly

Inspection or maintenance can be accomplished without removing the valve from the line. Repair kits with new diaphragm and disc are recommended to be on hand before work begins.

**WARNING:** Maintenance personnel can be injured and equipment damaged if disassembly is attempted with pressure in the valve. **SEE CAUTION.**

1. Close upstream and downstream isolation valves **and independent operating pressure when used** to shut off all pressure to the valve.
2. Loosen tube fittings in the pilot system to remove pressure from valve body and cover chamber. After pressure has been released from the valve, use care to remove the controls and tubing. Note and sketch position of tubing and controls for re-assembly. The schematic in front of the Technical Manual can be used as a guide when reassembling pilot system.
3. Remove cover nuts and remove cover. If the valve has been in service for any length of time, chances are the cover will have to be loosened by driving upward along the edge of the cover with a **dull cold chisel**.

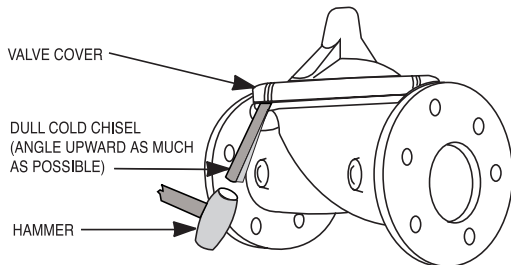

On 6" and smaller valves block and tackle or a power hoist can be used to lift valve cover by inserting proper size eye bolt in place of the center cover plug. on 8" and larger valves there are 4 holes (5/8" – 11 size) where jacking screws and/or eye bolts may be inserted for lifting purposes. **Pull cover straight up** to keep from damaging the integral seat bearing and stem.

#### COVER CENTER PLUG SIZE

Valve Size	Thread Size (NPT)
1 1/4" – 1 1/2"	1/4"
2" – 3"	1/2"
4" – 6"	3/4"
8" – 10"	1"
12"	1 1/4"
14"	1 1/2"
16"	2"
24"	2"
36"	2"

4. Remove the diaphragm and disc assembly from the valve body. With smaller valves this can be accomplished by hand by **pulling straight up on the stem so as not to damage the seat bearing**. On large valves, an eye bolt of proper size can be installed in the stem and the diaphragm assembly can be then lifted with a block and tackle or power hoist. Take care not to damage the stem or bearings. The valve won't work if these are damaged.

#### VALVE STEM THREAD SIZE

Valve Size	Thread Size (UNF Internal)
1 1/4" – 2 1/2"	10–32
3" – 4"	1/4–28
6" – 14"	3/8–24
16"	1/2–20
24"	3/4–16
36"	3/4–16

5. The next item to remove is the stem nut. Examine the stem threads above the nut for signs of mineral deposits or corrosion. If the threads are not clean, use a wire brush to remove as much of the residue as possible. Attach a good fitting wrench to the nut and give it a sharp "rap" rather than a steady pull. Usually several blows are sufficient to loosen the nut for further removal. On the smaller valves, the entire diaphragm assembly can be held by the stem in a vise **equipped with soft brass jaws** before removing the stem nut.

The use of a pipe wrench or a vise without soft brass jaws scars the fine finish on the stem. No amount of careful dressing can restore the stem to its original condition. Damage to the finish of the stem can cause the stem to bind in the bearings and the valve will not open or close.

6. After the stem nut has been removed, the diaphragm assembly breaks down into its component parts. Removal of the disc from the disc retainer can be a problem if the valve has been in service for a long time. Using two screwdrivers inserted along the outside edge of the disc usually will accomplish its removal. Care should be taken to preserve the spacer washers in water, particularly if no new ones are available for re-assembly.

7. The only part left in the valve body is the seat which ordinarily does not require removal. Careful cleaning and polishing of inside and outside surfaces with 400 wet/dry sandpaper will usually restore the seat's sharp edge. If, however, it is badly worn and replacement is necessary, it can be easily removed.

Seats in valve sizes 1 1/4" through 6" are threaded into the valve body. They can be removed with accessory X109 Seat Removing Tool available from the factory. On 8" and larger valves, the seat is held in place by flat head machine screws. Use a tight-fitting, long shank screwdriver to prevent damage to seat screws. If upon removal of the screws the seat cannot be lifted out, it will be necessary to use a piece of angle or channel iron with a hole drilled in the center. Place it across the body so a long stud can be inserted through the center hole in the seat and the hole in the angle iron. By tightening the nut a uniform upward force is exerted on the seat for removal.

**NOTE:** Do not lift up on the end of the angle iron as this may force the integral bearing out of alignment, causing the stem to bind.

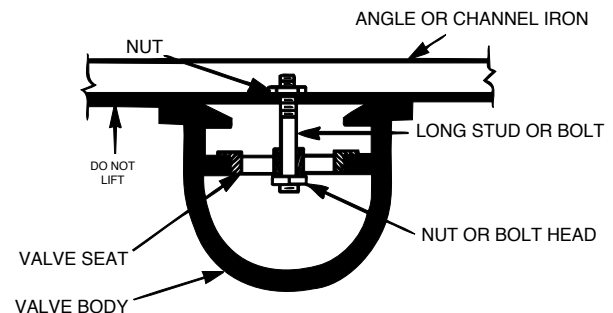

---

## Lime Deposits

One of the easiest ways to remove lime deposits from the valve stem or other metal parts is to dip them in a 5-percent muriatic acid solution just long enough for the deposit to dissolve. This will remove most of the common types of deposits. **CAUTION: USE EXTREME CARE WHEN HANDLING ACID.** Rinse parts in water before handling. If the deposit is not removed by acid, then a fine grit (400) wet or dry sandpaper can be used with water.

## Inspection of Parts

After the valve has been disassembled, each part should be examined carefully for signs of wear, corrosion, or any other abnormal condition. Usually, it is a good idea to replace the rubber parts (diaphragm and disc) unless they are free of signs of wear. These are available in a repair kit. Any other parts which appear doubtful should be replaced. **WHEN ORDERING PARTS, BE SURE TO GIVE COMPLETE NAMEPLATE DATA, ITEM NUMBER AND DESCRIPTION.**

**NOTE:** If a new disc isn't available, the existing disc can be turned over, exposing the unused surface for contact with the seat. The disc should be replaced as soon as practical.

---

## Reassembly

1. Reassembly is the reverse of the disassembly procedure. If a new disc has been installed, it may require a different number of spacer washers to obtain the right amount of "grip" on the disc. When the diaphragm assembly has been tightened to a point where the diaphragm cannot be twisted, the disc should be compressed very slightly by the disc guide. Excessive compression should be avoided. Use just enough spacer washers to hold the disc firmly without noticeable compression.

**2. MAKE SURE THE STEM NUT IS VERY TIGHT.** Attach a good fitting wrench to the nut and give it a sharp "rap" rather than a steady pull. Usually several blows are sufficient to tighten the stem nut for final tightening. Failure to do so could allow the diaphragm to pull loose and tear when subjected to pressure.

3. Carefully install the diaphragm assembly by lowering the stem through the seat bearing. Take care not to damage the stem or bearing. Line up the diaphragm holes with the stud or bolt holes on the body. On larger valves with studs, it may be necessary to hold the diaphragm assembly up part way while putting the diaphragm over the studs.

4. Put spring in place and replace cover. Make sure diaphragm is lying smooth under the cover.

5. Tighten cover nuts firmly using a cross-over pattern until all nuts are tight.

6. Test Hytrol Valve before re-installing pilot valve system.

---

## Test Procedure After Valve Assembly

There are a few simple tests which can be made in the field to make sure the Hytrol Valve has been assembled properly. Do these before installing pilot system and returning valve to service. These are similar to the three troubleshooting tests.

1. Check the diaphragm assembly for freedom of movement after all pressure is removed from the valve. **SEE CAUTION.** Insert fabricated tool into threaded hole in top of valve stem, and lift the diaphragm assembly manually. Note any roughness, sticking or grabbing. The diaphragm assembly should move smoothly throughout entire valve stroke. The tool is fabricated from rod that is threaded on one end to fit valve stem (See chart in Step 4 of "Disassembly" section.) and has a "T" Bar handle of some kind on the other end for easy gripping.

Place marks on this diaphragm assembly lifting tool when the valve is closed and when manually positioned open. The distance between the two marks should be approximately the stem travel shown in stem travel chart. (See "Freedom of Movement Check" section.) If the stroke is different than that shown, there is a good reason to believe something is mechanically restricting the stroke of the valve. The cover must be removed, the obstruction located and removed. (See "Maintenance" Section for procedure.)

Due to the weight of the diaphragm assembly this procedure is not possible on valves 8" and larger. On these valves, the same determination can be made by carefully introducing a low pressure-less than five psi) into the valve body with the cover vented. **SEE CAUTION.** Looking in cover center hole see the diaphragm assembly lift easily without hesitation, and then settle back easily when the pressure is removed.

2. To check the valve for drip-tight closure, a line should be connected from the inlet to the cover, and pressure applied at the inlet of the valve. If properly assembled, the valve should hold tight with as low as ten PSI at the inlet. See "Tight Sealing Check" section.)

3. With the line connected from the inlet to the cover, apply full working pressure to the inlet. Check all around the cover for any leaks. Re-tighten cover nuts if necessary to stop leaks past the diaphragm.

4. Remove pressure, then re-install the pilot system and tubing exactly as it was prior to removal. **Bleed air from all high points.**

5. Follow steps under "Start-Up and Adjustment" Section in Technical Manual for returning complete valve back to service.

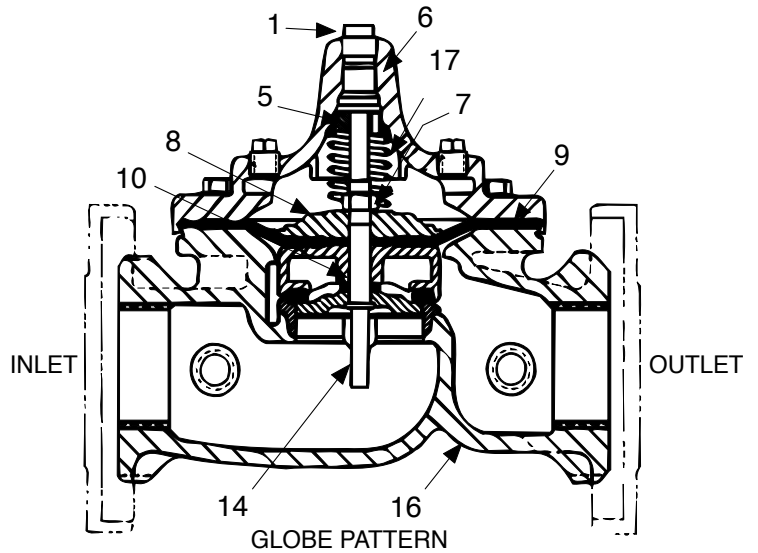
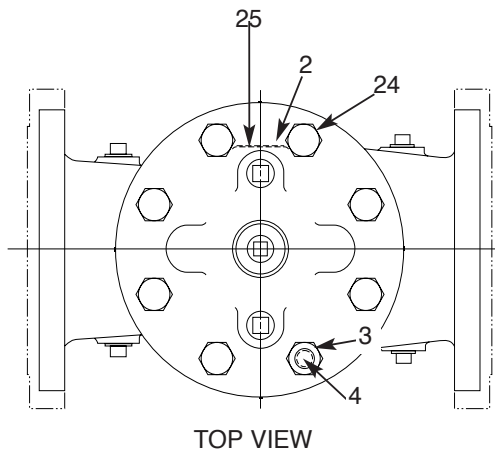

### PARTS LIST

Item	Description
1.	Pipe Plug
2.	Drive Screws (for nameplate)
3.	Hex Nut (8" and larger)
4.	Stud (8" and larger)
5.	Cover Bearing
6.	Cover
7.	Stem Nut
8.	Diaphragm Washer
9.	Diaphragm
10.	Spacer Washers
11.	Disc Guide
12.	Disc Retainer
13.	Disc
14.	Stem
15.	Seat
16.	Body
17.	Spring
22.	Flat Head Screws (8" and larger)
23.	Seat O-Ring
24.	Hex head Bolt (1 1/4" thru 4")
25.	Nameplate
26.	Upper Spring Washer (Epoxy coated valves only)
27.	Lower Spring Washer (Epoxy coated valves only)
28.	Cover Bearing Housing (16" only)
29.	Cover O-Ring (16" only)
30.	Hex Bolt (16" only)
31.	Pipe Cap (16" only)

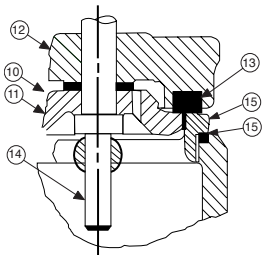
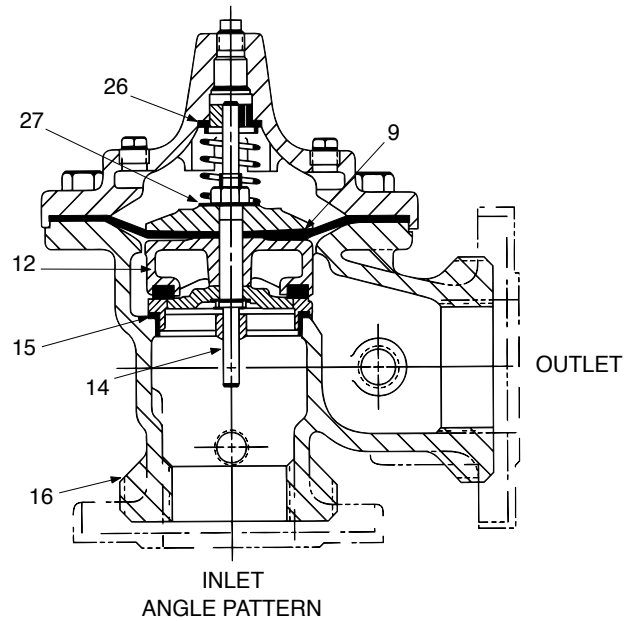

1 1/4" - 6" SEAT DETAIL

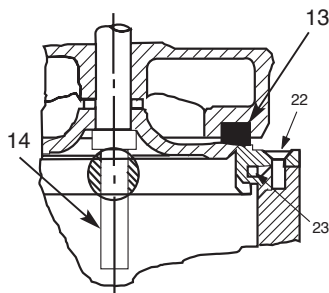

8" - 24" SEAT DETAIL

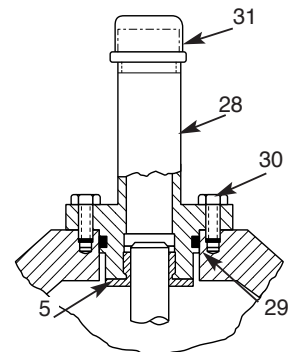

16" COVER DETAIL



# — MODEL — 100-01 Hytrol Valve Service Data

## Description 100-01 Hytrol Valve

The Cla-Val Model 100-01 Hytrol Valve is a main valve for Cla-Val Automatic Control Valves. It is a hydraulically operated, diaphragm-actuated, globe or angle pattern valve.

This valve consists of three major components; body, diaphragm assembly, and cover. The diaphragm assembly is the only moving part. The diaphragm assembly uses a diaphragm of nylon fabric bonded with synthetic rubber. A synthetic rubber disc, contained on three and one half sides by a disc retainer and disc guide, forms a seal with the valve seat when pressure is applied above the diaphragm. The diaphragm assembly forms a sealed chamber in the upper portion of the valve, separating operating pressure from line pressure.

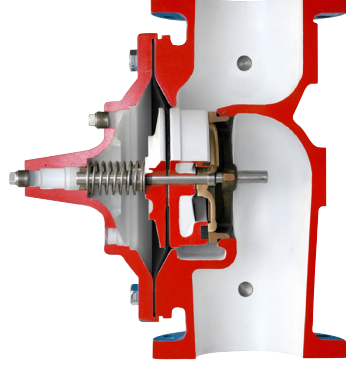

## Description 100-20 600 Series Hytrol Valve

The Cla-Val Model 100-20 Hytrol Valve (600 Series main valve) have only one part -the body- that is different from standard 100 Series Cla-Val main valve parts. The remaining parts of the 600 series main valve are standard Cla-Val main valve parts. All service and maintenance information for the standard 100 Series main valves also apply to the 600 series main valves.

The most important thing to remember when ordering main valve repair kits and replacement parts, except for the body, all other parts are going to be for a smaller size main valve. Cla-Val identifies main valve parts with the flange size of the standard 100 Series main valve. Refer to the "Main Valve Sizes" chart below.

## HYTROL Service Data

HYTROL SIZE		Stem Travel		Cover Capacity		Valve Stem Thread	Cover Center Plug NPT	Cover Nut or Bolt		Cover Lifting Holes UNC	Cover Plug	Cover Torque	Stem Nut Torque	
inches	mm	inches	mm	Gallons	Liters	UNF-Internal		Thread (Bolt)	Socket		Thread	in. Lbs.	Thread	Socket (Long)
1"	25	0.3	8	0.020	0.07	10-32	1/4"	1/4" - 20 (B)	7/16"	8		4	3/8" - 24	
1 1/4"	32	0.4	10	0.020	0.07	10-32	1/4"	5/16" - 18 (B)	1/2"	8		8	7/16" 20	
1 1/2"	40	0.4	10	0.020	0.07	10-32	1/4"	5/16" - 18 (B)	1/2"	8		8	7/16" 20	
2"	50	0.6	15	0.032	0.12	10-32	1/2"	3/8" - 16 (B)	9/16"	8	3/8"	12	1/2" - 20	3/4"
2 1/2"	65	0.7	18	0.043	0.16	10-32	1/2"	7/16" - 14 (B)	5/8"	8	1/2"	20	5/8" - 18	15/16"
3"	80	0.8	20	0.080	0.30	1/4 - 28	3/4"	1/2" - 13 (B)	3/4"	8	1/2"	30	5/8" - 18	15/16"
4"	100	1.1	23	0.169	0.64	3/8 - 24	1"	3/4" - 10 (B)	1 1/8"	8	3/4"	110	3/4" - 16	1 1/16"
6"	150	1.7	43	0.531	2.00	3/8 - 24	3/4"	3/4" - 10 (B)	1 1/8"	12	3/4"	110	7/8" - 14	1 5/16"
8"	200	2.3	58	1.26	4.80	3/8 - 24	1"	7/8" - 9	1 7/16	16	1"	110	1 1/8" - 12	1 13/16"
10"	250	3.0	71	2.51	9.50	3/8 - 24	1 1/2"	1-1/8" - 7	1 13/16	20	1 1/2"	160	1 1/2" - 12	1 7/8"
12"	300	3.4	86	4.0	15.10	3/8 - 24	1 1/2"	1-1/8" - 7	1 13/16	20	1 1/2"	390	1 1/2" - 12	2 1/2"
14"	350	3.9	99	6.5	24.60	3/8 - 24	2"	1-1/4" - 7	2"	20	1"	545	1 1/2" - 12	2 1/2"
16"	400	4.5	114	9.5	36.20	1/2 - 20	2"	1-1/4" - 7	2"	20	1"	545	2" - 16	3"
24"	600	6.5	165	29.0	108.80	3/4 - 16 *	3/4"	1-1/2" - 12	2 3/8"	24	1"	800	3" - 12	Special

Grade 5 Bolts  
"Heavy" Grade Nuts

\* Adapter p/n 2594101E  
inside 1/4" - 28  
Tighten cover nuts in a "star" cross-over pattern

\*\*Must Use ONLY  
Cla-Val Supplied part

# 100-01 Hytrol Main Valve Assembly

## BOLT/NUT TORQUING PROCEDURES ON VALVE COVERS

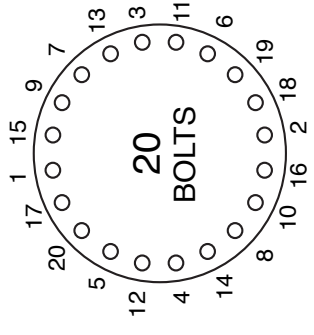
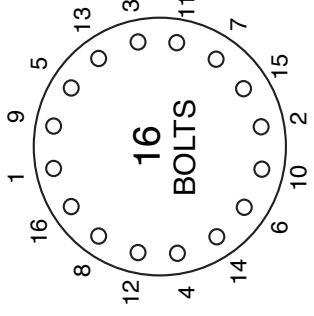
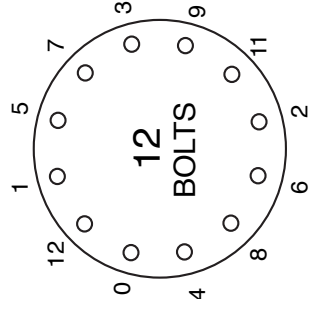
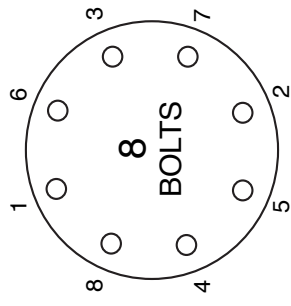
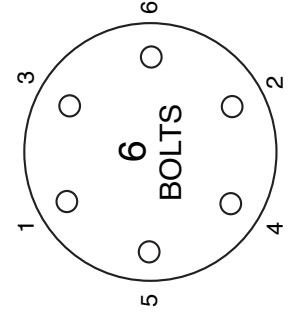
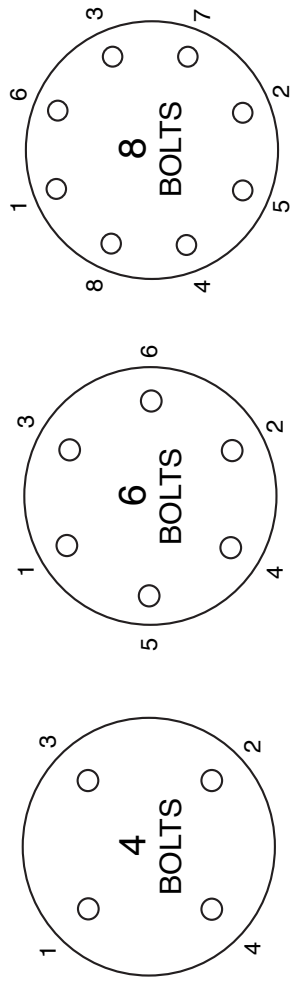
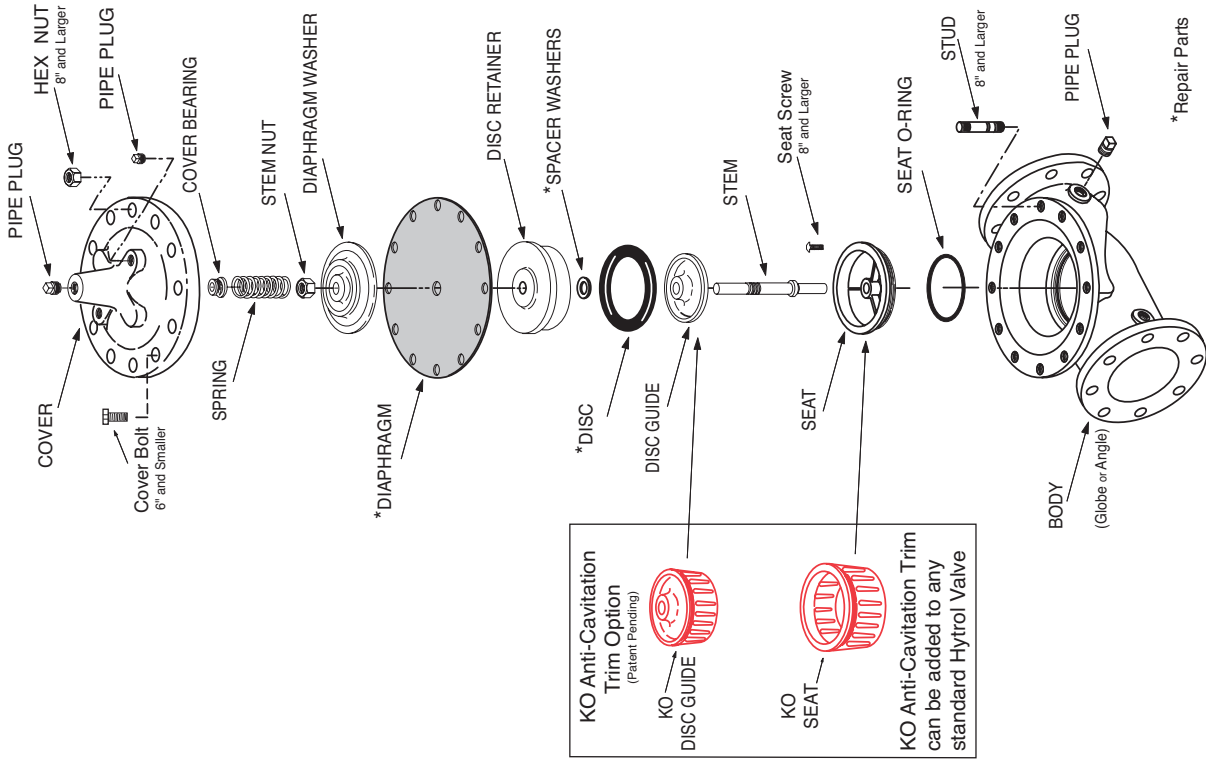

Follow this procedure when reassembling MAIN Valve:

1. Tightens bolts/nuts in a "Star" or "Cross-Over" Pattern following the numbers shown above to insure that cover seats evenly on the diaphragm material and body.
2. Torque the bolt/nuts in three stages:
  - A. To approximately 10% of final torque valve.
  - B. To approximately 75% of final torque valve.
  - C. To final required torque valve.
3. Valves that are to be tested to 375 PSI or higher should be retorqued after 24 hours.

\*Repair Parts

**KO Anti-Cavitation Trim Option**  
(Patent Pending)

**KO DISC GUIDE**

**KO SEAT**

KO Anti-Cavitation Trim can be added to any standard Hytrol Valve



— MODEL — **CRL**

# Pressure Relief Control

**DESCRIPTION**

The CRL Pressure Relief Control is a direct acting, spring loaded, diaphragm type relief valve. It may be used as a self-contained valve or as a pilot control for a Cla-Val Main valve. It opens and closes within very close pressure limits.

**INSTALLATION**

The CRL Pressure Relief Control may be installed in any position. The control body (7) has one inlet and one outlet port with a side pipe plug (24) at each port. These plugs are used for control connections or gauge applications. The inlet in the power unit body (6) is the sensing line port. A flow arrow is marked on the body casting.

**OPERATION**

The CRL Pressure Relief Control is normally held closed by the force of the compression spring above the diaphragm; control pressure is applied under the diaphragm.

When the controlling pressure exceeds the spring setting, the disc is lifted off its seat, permitting flow through the control.

When controlling pressure drops below spring setting, the spring returns the control to its normally closed position.

**ADJUSTMENT PROCEDURE**

The CRL Pressure Relief Control can be adjusted to provide a relief setting at any point within the range found on the nameplate.

Pressure adjustment is made by turning the adjustment screw (9) to vary the spring pressure on the diaphragm. Turning the adjustment screw clockwise increases the pressure required to open the valve. Counterclockwise decreases the pressure required to open the valve.

When pressure adjustments are complete the jam nut (10) should be tightened and the protective cap (1) replaced. If there is a problem of tampering, lock wire holes have been provided in cap and cover. Wire the cap to cover and secure with lead seal.

**DISASSEMBLY**

The CRL Pressure Relief Control does not need to be removed from the line for disassembly. Make sure that pressure shut down is accompanied prior to disassembly. If the CRL is removed from the line for disassembly be sure to use a soft jawed vise to hold body during work.

Refer to Parts List Drawing for Item Numbers.

1. Remove cap (1), loosen jam nut (10) and turn adjusting screw counterclockwise until spring tension is relieved.
2. Remove the eight screws (4) holding the cover (3) and powerunit body (6). Hold the cover and powerunit together and place on a suitable work surface.  
See NOTE under REASSEMBLY.
3. Remove the cover (3) from powerunit body (6). The spring (12) and two spring guides (11).
4. Remove nut (13) from stem (19) and slide off the belleville washer (14), the upper diaphragm washer (15) and the diaphragm (16).
5. Pull the stem (19) with the disc retainer assembly (21) through the bottom of powerunit. The lower diaphragm washer (17) will slide off of stem top.
6. Remove jam nut (23) and disc retainer assembly (21) from stem. Use soft jawed pliers or vise to hold stem. The polished surface of stem must not be scored or scratched.
7. The seat (22) need not be removed unless it is damaged. If removal is necessary use proper size socket wrench and turn counterclockwise.  
Note: Some models have an integral seat in the body (7).

**INSPECTION**

Inspect all parts for damage, or evidence of cross threading. Check diaphragm and disc retainer assembly for tears, abrasions or other damage. Check all metal parts for damage, corrosion or excessive wear.

**REPAIR AND REPLACEMENT**

Minor nicks and scratches may be polished out using 400 grit wet or dry sandpaper fine emery or crocus cloth. Replace all O-rings and any damaged parts.

When ordering replacement parts, be sure to specify parts list item number and all nameplate data.

**REASSEMBLY**

In general, reassembly is the reverse of disassembly. However, the following steps should be observed:

1. Lubricate the O-Ring (18) with a small amount of a good grade of waterproof grease, (Dow Corning 44 medium grade or equal). Use grease sparingly and install O-ring in powerunit body (6).
2. Install stem (19) in powerunit body (6). Use a rotating motion with minimum pressure to let stem pass through O-ring.  
Do Not Cut O-Ring.
3. Install O-ring (5) at top of stem (19). Place lower diaphragm washer (17) on the stem with the serrated side up. Position diaphragm (16), upper diaphragm washer (15), with serration down, and belleville washer (14) with concave side down.
4. Position powerunit body (6) as shown on parts list drawing (top view).
5. Continue reassembly as outlined in disassembly steps 1 through 3.

**Note:** Item (4) Screw will have a quantity of 8 for the 0-75 and 20-200psi design and a quantity of 4 for the 100-300psi design. Item (25) Screw is used on the 100-300psi design only. Install item (25), before item (4) for preload of item (12) spring.

SYMPTOM	PROBABLE CAUSE	REMEDY
Fails to open.	Controlling pressure too low.	Back off adjusting screw until valve opens.
Fails to open with spring compression removed.	Mechanical obstruction, corrosion, scale build-up on stem.	Disassemble, locate, and remove obstruction, scale.
Leakage from cover vent hole when controlling pressure is applied.	Diaphragm Damage	Disassembly replace damaged diaphragm.
	Loose diaphragm assembly.	Tighten upper diaphragm washer.
Fails to close.	No spring compression.	Re-set pressure adjustment.
Fails to close with spring compressed.	Mechanical obstruction.	Disassemble, locate and remove obstruction.



**CRL**

# 1/2" & 3/4" PRESSURE RELIEF CONTROL

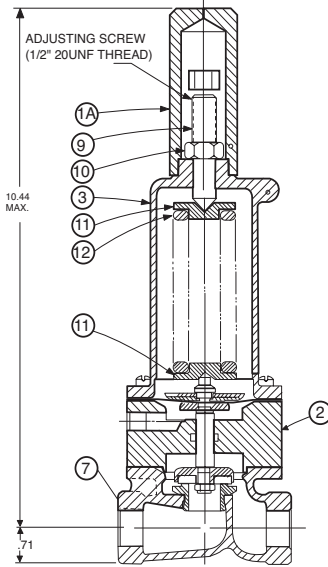
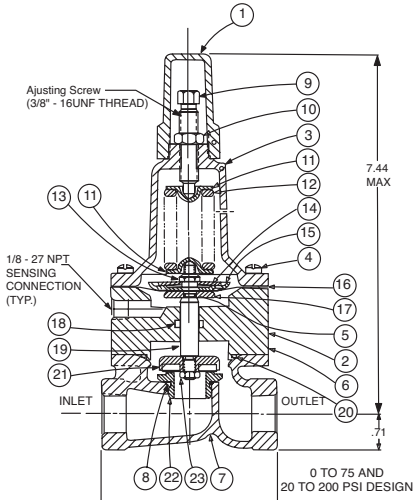
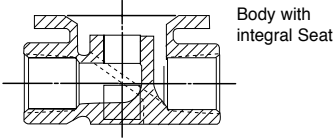
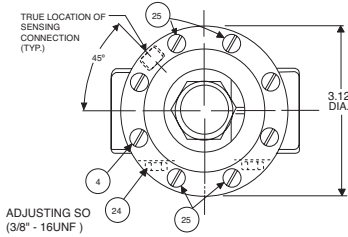

SIZE	SPRING RANGE	PART NUMBER
1/2"	0-75 PSI	79222-01E
1/2"	20-200 PSI	79222-02C
1/2"	100-300 PSI	82809-01D
3/4"	0-75 PSI	79229-01K
3/4"	20-200 PSI	79229-02H
3/4"	100-300 PSI	86005-01E

For 100-450 PSI Contact Factory

CRL RANGE PSI	APPROX. INCREASE FOR EACH CLOCKWISE TURN OF ADJUSTING SCREW
0 to 75	8.5 PSI
20 to 200	28.0 PSI
100 to 300	18.0 PSI

**When ordering parts please specify:**  
 1. All Nameplate Data  
 2. Item Part Number  
 3. Item Description

Item	Description	Material	Part Number		
			0-75	20-200	100-300
1	Cap	Plastic	67628J	67628J	1257601D
1A	Cap 100 to 300 psi Design	Plastic	1257601D	1257601D	1257601D
2	Nameplate	Brass	--	--	--
3	Cover	Bronze	C2544K	C2544K	44587E
4*	Screw Fil.Hd.10-32 x 1.88	303 SS	6757867E	6757867E	6757867E
5*	O-Ring	Rubber	00902H	00902H	00902H
6	Body, Powerunit	Bronze	7920504D	7920504D	7920504D
7	1/2" Body	Bronze	C7928K	C7928K	C7928K
	3/4" Body	Bronze	C9083B	C9083B	C9083B
8*	O-Ring, Seat	Rubber	00718H	00718H	00718H
9	Screw, Adjusting	Brass	7188201D	7188201D	7188201D
10	Nut Hex (Locking)	303 SS	6780106J	6780106J	6780106J
11	Guide, Spring	303 SS	71881H	71881H	1630301J
12	Spring,	CHR/VAN	71881H	71881H	1630201A
13	Nut, Stem, Upper	Bronze	73034B	73034B	73034B
14	Washer, Belleville	Steel	7055007E	7055007E	7055007E
15	Washer, Diaphragm (upper)	303 SS	71891G	71891G	71891G
16*	Diaphragm	Rubber	C1505B	C1505B	C1505B
17	Washer, Diaphragm (lower)	303 SS	45871B	45871B	45871B
18*	O-Ring, Stem	Rubber	00746J	00746J	00746J
19	Stem	303 SS	8982401F	8982401F	8982401F
20*	O-Ring, Body	Rubber	00767E	00767E	00767E
21*	Retainer Assembly, Disc	303 SS	C8964D	C8964D	C8964D
22	Seat	303 SS	62187A	62187A	62187A
23	Nut, hex, Stem, Lower	Bronze	6779806G	6779806G	6779806G
24	Pipe Plug	Bronze	6784701C	6784701C	6784701C
25*	Screw Fil.Hd, 10-32 x 2.25 (Qty 4 on 100-300 psi)	303 SS	6757867E	6757867E	6757867E
	<b>FACTORY SET POINT</b>		<b>50 PSI</b>	<b>60 PSI</b>	<b>100 PSI</b>
	<b>REPAIR KIT*</b>		9170007A	9170007A	9170007A



# Regulator Spring Color Coding Chart

## Dwg#47117

\* THESE FIGURES ARE ONLY APPROXIMATE. FINAL ADJUSTMENTS SHOULD BE MADE WITH A PRESSURE GAGE.

WIRE SIZE	SPRING NUMBER	COLOR	WIRE MATERIAL	CATALOG NUMBER	PSI RANGE	*PSI PER TURN
.080 DIA.	C0492D	BLUE	S.S.	CDB-7	0-7 0-7	.75 .75
.080 DIA.	82575C	--	S.S.	CRD CRD-10A	1.9-6.5 1.9-6.5	.61 .49
.116 DIA.	81594E	--	S.S.	CRD CRD-10A	2-30 2-30	3.0 2.4
.120 DIA.	V5654J	GREEN	CHR VAN	CRL-5A CRD	5-25 10-40	4.0 4.0
.162 DIA.	32447F	NATURAL	S.S.	CDB-7 CRL-5A CRL-13	10-60 10-60 10-60	12.0 12.0 12.0
.162 DIA.	V5695B	YELLOW	MUSIC WIRE	CDB-7 CRL-5A CRL-13	20-80 20-80 20-80	14.5 14.5 14.5
.207 DIA.	C1124B	CAD PLT	MUSIC WIRE	CDB-7 CRL-13 CRL-5A	50-150 50-150 50-150	29.5 29.5 29.5
.225 DIA.	V6515A	RED	MUSIC WIRE	CDB-7 CRL-13 CRL-5A	65-180 65-180 65-180	44.0 44.0 44.0
.115 X .218	71884B	RED	CHR VAN	CRL CRD CRD-10A	0-75 15-75 15-75	8.5 9.0 7.2
.118 X .225	71885J	GREEN	CHR VAN	CRL CRD CRD-10A	20-200 30-300 30-300	28.0 27.0 22.4
.225 X .295	163021A	CAD PLT	CHR VAN	CRL-5A CRL	100-300 100-300	18.0 18.0
.440 X .219	48211H	CAD PLT	STEEL	CRA-18 CRD-22 CRL-4A	200-450 200-450 100-450	17.0 17.0 17.0
WIRE SIZE	SPRING NUMBER	COLOR	WIRE MATERIAL	CATALOG NUMBER	RANGE FEET	*FEET PER TURN
.080 DIA.	C0492D	BLUE	S.S.	CRA CRD-2	4.5-15 4.5-15	.82 .82
.375 DIA.	87719B 1 SPRING 2 SPRINGS 3 SPRINGS 4 SPRINGS 5 SPRINGS	EPOXY COATED	CHROME SILICON	CDS-5	5.40 30-80 70-120 110-120 150-200	1.0 2.0 3.0 4.0 5.0
.072 DIA.	V0597A	--	302SS	CVC	1-17	.7
.375 DIA.	V2933502H 1 SPRING 2 SPRINGS 3 SPRINGS 4 SPRINGS 5 SPRINGS	EPOXY COATED	CHROME SILICON	CDS-6	5.40 30-80 70-120 110-120 150-200	.75 1.50 2.20 3.00 3.70

THE FOLLOWING CONTROL & SPRING P/N#S WERE REMOVED, 32656B, 31554K, 44591G, V65695B, & V5695B.  
ADDED CRL-13, CRL-5A, CRA, CRA-10A, CHANGED SPRING RANGES TO MATCH CURRENT CONTROLS.

\*This drawing is the property of CLA-VAL and same and copies made thereof, if any, shall be returned to it upon demand. Delivery and disclosure hereof are made solely upon condition that the same shall not be used, copied or reproduced, nor shall the subject hereof be disclosed in any manner to anyone for any purpose, except as herein authorized, without prior approval of CLA-VAL. Whether or not the equipment or information shown hereon is patented or otherwise protected, full title and copyrights if any, in and to this drawing and/or information delivered or submitted are fully reserved by CLA-VAL.



# X44A

## Strainer and Orifice Assembly

BRONZE BODY — S.S. ORIFICE

3/8" x 3/8"

X44A STOCK NO.	ORIFICE DIA.	ORIFICE PLUG PART # (ITEM 5)
71310-01	.031	94132-01
-02	.046	-02
-03	.062	-03
-04	.078	-04
-05	.093	-05
-06	.109	-06
*-07	.125	-07
-08	.140	-08
-09	.156	-09
-10	.187	-10

\*Standard

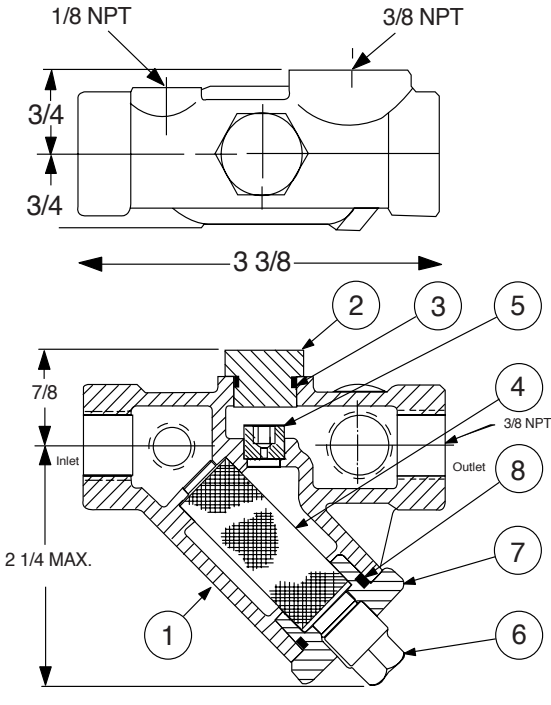

**When ordering parts, please specify:**

- All Nameplate Data
- Item Number
- Description
- Recommended Spare Parts

ITEM	DESCRIPTION	MATERIAL	QTY.
1	Body	Red Brs.	1
2	Plug, Top	Brass	1
3	"O" Ring, Plug Top	Syn. Rub.	1
4	Screen	Monel	1
5	Orifice Plug	Delrin	1
6	Plug, Pipe	Brass	1
7	Strainer Plug	S.S.	1
8	"O" Ring, Strainer Plug	Syn. Rub.	1



# 81-01

## 3/8" Check Valve

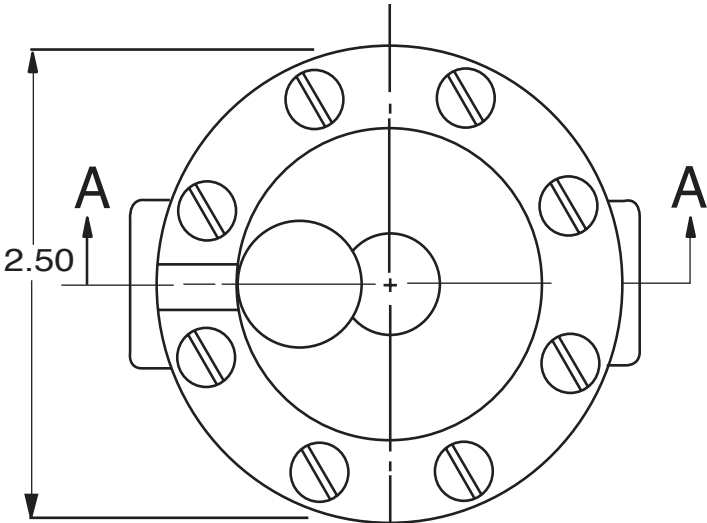

ITEM DESCRIPTION

1.	Cover Screw (8 Required)
2.	Cover
*3.	Spring
4.	Diaphragm Washer
*5.	Diaphragm
*6.	Disc Retainer Assembly
7.	Body Plug (3/8 NPT)
8.	Body (Threaded)

\*Recommended Spare Parts

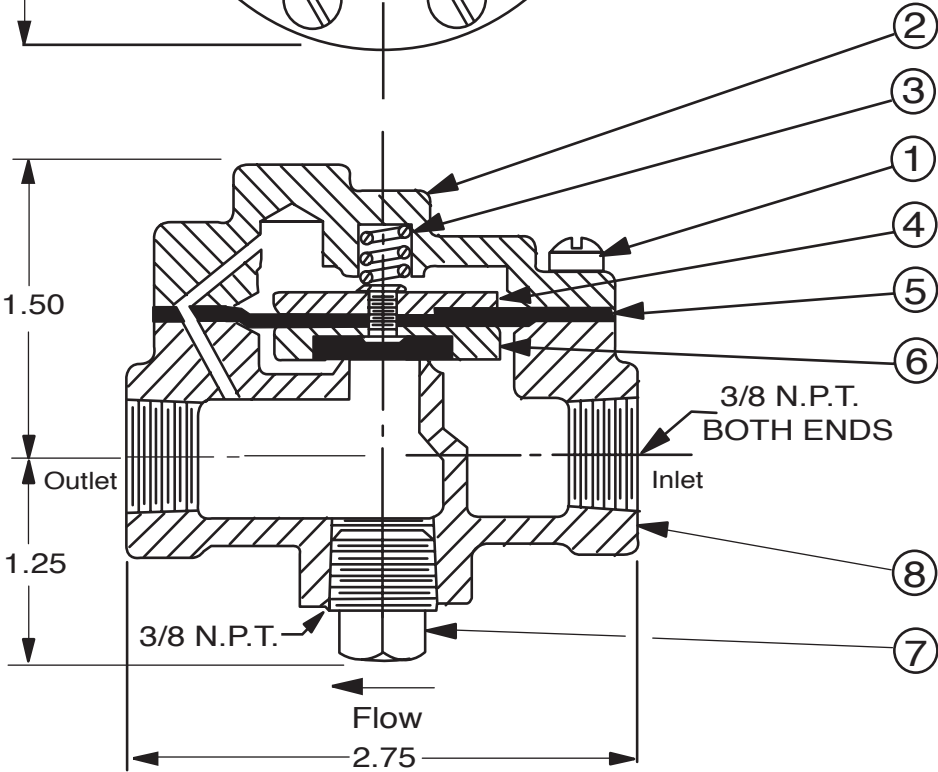

SECTION AA

**When ordering parts, please specify:**

- All nameplate data
- Description
- Part Number
- Item Number
- Material



# 81-01

## 1/2" & 3/4 Check Valve

### ITEM DESCRIPTION

1.	Body	1
2.	Cover	1
*3.	Diaphragm	1
4.	Guide Disc	1
*5.	Disc Retainer Assembly	1
7.	Nut Hex 3/8 - 24UNF 28	1
8.	Plug Pipe Hex NPT	2
9.	Screw, Fil HD 10 32UNF 2 x 2LG	8
10.	Spring	1
11.	Nameplate	1

\*Recommended Spare Parts

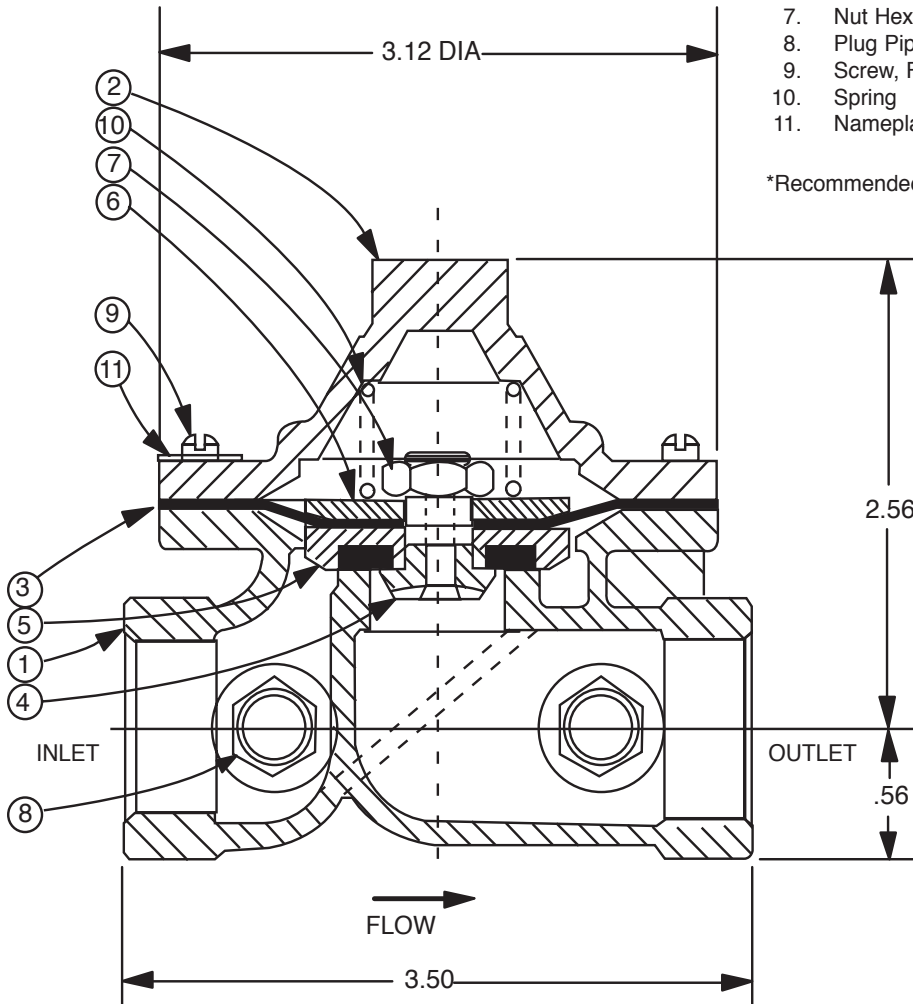

### When ordering parts, please specify:

- All nameplate data
- Description
- Part Number
- Item Number
- Material



— MODEL — **Pressure Gauge**  
**Fire Protection Sprinkler Service**

- **UL listed and Factory Mutual approved**
- **Corrosion-resistant ABS case**
- **Heat-resistant polycarbonate push-in window**
- **Patented PowerFlex™ movements with polyester segment**
- **True Zero indication™, a unique safety feature**

**Description**

Ashcroft fire protection sprinkler gauges are Underwriters Laboratory listed and Factory Mutual approved for fire protection sprinkler service. The case material on Type 1 005P XUL gauges is ABS. The 0-300 psi pressure range is used on "wet" systems where water is available to the sprinkler heads. The 0-80 retard to 250 psi pressure range is used on dry systems where the lines are filled with air pressure until system activation.

The patented PowerFlex movement with polyester segment is designed to provide unequalled shock and vibration resistance resulting in superior performance and extended gauge life.

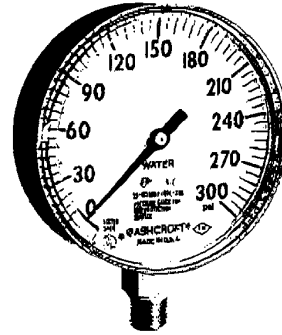

True Zero indication, a standard feature on these gauges, reduces the potential risk of installing a damaged gauge on your equipment.

**Gauge Options**

- Customized dials
- Other UL listed ranges on application

**Specification**

<b>Type no:</b>	1005P, XUL
<b>Size:</b>	3 1/2"
<b>Case:</b>	ABS (Acrylonitrile Butadiene Styrene)
<b>Ring:</b>	None
<b>Window:</b>	Polycarbonate. push-in
<b>Dial:</b>	Black figures on white Background
<b>Pointer:</b>	Black, aluminum
<b>Bourdon tube:</b>	"C" shaped bronze
<b>Movement:</b>	Patented PowerFlex
<b>Socket:</b>	Brass, soft soldered
<b>Restrictor:</b>	None
<b>Connection:</b>	1/4 NPT lower
<b>Ranges:</b>	0-300 psi (water) 0-80 retard to 250 psi (air) UL 393 Listed, UL of Canada Listed and FM approved. Equivalent (single or dual scale) metric scales are available

P/N 9028433C



— MODEL — **X46**

# Flow Clean Strainer



**X46A Straight**

- Self Scrubbing Cleaning Action
- Straight Type or Angle Type

The Cla-Val Model X46 Strainer is designed to prevent passage of foreign particles larger than .015". It is especially effective against such contaminant as algae, mud, scale, wood pulp, moss, and root fibers. There is a model for every Cla-Val. valve.

**X46B Angle**

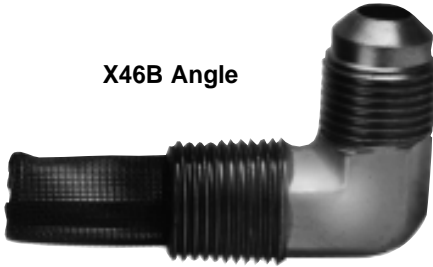

The X46 Flow Clean strainer operates on a velocity principle utilizing the circular "air foil" section to make it self cleaning. Impingement of particles is on the "leading edge" only. The low pressure area on the downstream side of the screen prevents foreign particles from clogging the screen. There is also a scouring action, due to eddy currents, which keeps most of the screen area clean.

## Dimensions (In Inches)

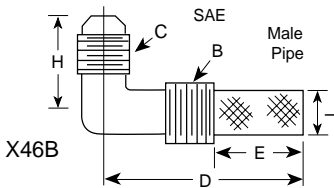

X46 Angle Type B (In Inches)						
B(NPT)	C(SAE)	D	E	H	I	
1/8	1/4	1-3/8	5/8	7/8	1/4	
1/4	1/4	1-3/4	3/4	1	3/8	
3/8	1/4	2	7/8	1	1/2	
3/8	3/8	1-7/8	7/8	1	1/2	
1/2	3/8	2-3/8	1	1-1/4	5/8	

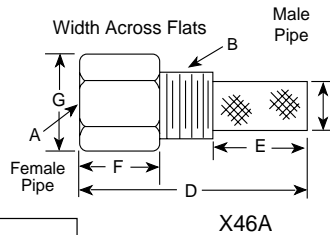

X46A Straight Type A (In Inches)						
A (NPT)	B (NPT)	D	E	F	G	I
1/8	1/8	1-3/4	3/4	1/2	1/2	1/4
1/4	1/4	2-1/4	1	3/4	3/4	3/8
3/8	3/8	2-1/2	1	7/8	7/8	1/2
3/8	1/2	2-1/2	1-1/4	1/2	7/8	3/4
1/2	1/2	3	1-1/4	1	1-1/8	3/4
3/8	3/4	3-3/8	2	1/2	1	7/8
3/4	3/4	4	2	1	1-1/2	7/8
3/8	1	4-1/4	2-3/4	1/2	1-3/8	7/8
1	1	4-1/2	2-3/4	1-1/4	1-3/4	7/8
1/2	1	4-1/4	2-3/4	1/2	1-3/8	7/8

### When Ordering, Please Specify:

- Catalog Number X46
- Straight Type or Angle Type
- Size Inserted Into and Size Connection
- Materials

## INSTALLATION

The strainer is designed for use in conjunction with a Cla-Val Main Valve, but can be installed in any piping system where there is a moving fluid stream to keep it clean. When it is used with the Cla-Val Valve, it is threaded into the upstream body port provided for it on the side of the valve. It projects through the side of the Main Valve into the flow stream. All liquid shunted to the pilot control system and to the cover chamber of the Main Valve passes through the X46 Flow Clean Strainer.

## INSPECTION

Inspect internal and external threads for damage or evidence of cross-threading. Check inner and outer screens for clogging, embedded foreign particles, breaks, cracks, corrosion, fatigue, and other signs of damage.

## DISASSEMBLY

Do not attempt to remove the screens from the strainer housing.

## CLEANING

After inspection, cleaning of the X46 can begin. Water service usually will produce mineral or lime deposits on metal parts in contact with water. These deposits can be cleaned by dipping X46 in a 5-percent muriatic acid solution just long enough for deposit to dissolve. This will remove most of the common types of deposits. **Caution: use extreme care when handling acid.** If the deposit is not removed by acid, then a fine grit (400) wet or dry sandpaper can be used with water. Rinse parts in water before handling. An appropriate solvent can clean parts used in fueling service. Dry with compressed air or a clean, lint-free cloth. Protect from damage and dust until reassembled.

## REPLACEMENT

If there is any sign of damage, or if there is the slightest doubt that the Model X46 Flow Clean Strainer may not afford completely satisfactory operation, replace it. Use Inspection steps as a guide. Neither inner screen, outer screen, nor housing is furnished as a replacement part. Replace Model X46 Flow Clean Strainer as a complete unit.

When ordering replacement Flow-Clean Strainers, it is important to determine pipe size of the tapped hole into which the strainer will be inserted (refer to column A or F), and the size of the external connection (refer to column B or G).



# — MODEL — 50B-4KG1/2050B-4KG1

## Product Identification

### How to Order

#### Proper Identification

For ordering repair kits, replacement parts, or for inquiries concerning valve operation it is important to properly identify Cla-Val products already in service. Include all nameplate data with your inquiry. Pertinent product data includes valve function, size, material, pressure rating, end details, type of pilot controls used and control adjustment ranges.

#### Identification Plate

For product identification, cast in body markings are supplemented by the identification plate illustrated on this page. The plate is mounted in the most practical position. **It is extremely important that this identification plate is not painted over, removed, or in any other way rendered illegible.**

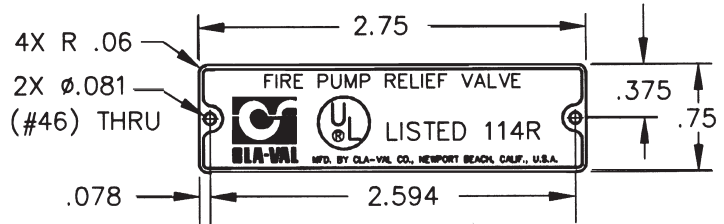

#### Specify when ordering

- Model Number
- Adjustment Range (As Applicable)
- Valve Size
- Optional Features
- Pressure Class

#### How To Order

There are many valves and controls manufactured by Cla-Val that are not listed due to the sheer volume. For information not listed, please contact your local Cla-Val representative.

#### Unless Otherwise Specified

- X43 "Y" Strainer is included.
- CK2 Isolation Valves is included in price on 6" and larger valve sizes.

#### Limited Warranty

Automatic valves and controls as manufactured by Cla-Val are warranted for one year from date of shipment against manufacturing defects in material and workmanship which develop in the service for which they are designed, provided the products are installed and used in accordance with all applicable instructions and limitations issued by Cla-Val.

We will repair or replace defective material, free of charge, which is returned to our factory, transportation charges prepaid, provided that, after inspection, the material is found to have been defective at time of shipment. This warranty is expressly conditioned on the purchaser's giving Cla-Val immediate written notice upon discovery of the defect.

Components used by Cla-Val but manufactured by others, are warranted only to the extent of that manufacturer's guarantee.

This warranty shall not apply if the product has been altered or repaired by others, and Cla-Val shall make no allowance or credit for such repairs or alterations unless authorized in writing by Cla-Val.

#### Terms Of Sale

##### ACCEPTANCE OF ORDERS

All orders are subject to acceptance by our main office at Newport Beach, California.

##### CREDIT TERMS

Credit terms are net thirty (30) days from date of invoice.

##### PURCHASE ORDER FORMS

Orders submitted on customer's own purchase order forms will be accepted only with the express understanding that no statements, clauses, or conditions contained in said order form will be binding on the Seller if they in any way modify the Seller's own terms and conditions of sales.

##### PRODUCT CHANGES

The right is reserved to make changes in pattern, design or materials when deemed necessary, without prior notice.

##### PRICES

All prices are F.O.B. Newport Beach, California, unless expressly stated otherwise on our acknowledgement of the order. Prices are subject to change without notice. The prices at which any order is accepted are subject to adjustment to the Seller's price in effect at the time of shipment. Prices do not include sales, excise, municipal, state or any other Government taxes. Minimum order charge \$75.00.

##### RESPONSIBILITY

We will not be responsible for delays resulting from strikes, accidents, negligence of carriers, or other causes beyond our control. Also, we will not be liable for any unauthorized product alterations or charges accruing there from.



## Disclaimer Of Warranties And Limitations Of Liability

The foregoing warranty is exclusive and in lieu of all other warranties and representations, whether expressed, implied, oral or written, including but not limited to any implied warranties or merchantability or fitness for a particular purpose. All such other warranties and representations are hereby cancelled.

Cla-Val shall not be liable for any incidental or consequential loss, damage or expense arising directly or indirectly from the use of the product. Cla-Val shall not be liable for any damages or charges for labor or expense in making repairs or adjustments to the product. Cla-Val shall not be liable for any damages or charges sustained in the adaptation or use of its engineering data and services. No representative of Cla-Val may change any of the foregoing or assume any additional liability or responsibility in connection with the product. The liability of Cla-Val is limited to material replacements F.O.B. Newport Beach, California.

## Risk

All goods are shipped at the risk of the purchaser after they have been delivered by us to the carrier. Claims for error, shortages, etc., must be made upon receipt of goods.

## EXPORT SHIPMENTS

Export shipments are subject to an additional charge for export packing.

## RETURNED GOODS

1. Customers must obtain written approval from Cla-Val prior to returning any material.
2. Cla-Val reserves the right to refuse the return of any products.
3. Products more than six (6) months old cannot be returned for credit.
4. Specially produced, non-standard models cannot be returned for credit.
5. Rubber goods cannot be returned for credit, unless as part of an unopened repair kit which is less than six months old.
6. Goods authorized for return are subject to a 35% (\$75 minimum) restocking charge and a service charge for inspection, reconditioning, replacement of rubber parts, retesting and repackaging as required.
7. Authorized returned goods must be packaged and shipped prepaid to Cla-Val., 1701 Placentia Avenue, Costa Mesa, California 92627-4475.



E-50B-4KG1 P.I.D. (R-8/05)

## CLA-VAL

PO Box 1325 Newport Beach CA 92659-0325  
Phone: 949-722-4800 • Fax: 949-548-5441

### CLA-VAL CANADA

4687 Christie Drive  
Beamsville, Ontario  
Canada LOR 1B4  
Phone: 905-563-4963  
Fax: 905-563-4040

### CLA-VAL EUROPE

Chemin des Mesanges 1  
CH-1032 Romanel/  
Lausanne, Switzerland  
Phone: 41-21-643-15-55  
Fax: 41-21-643-15-50

©COPYRIGHT CLA-VAL 2005 Printed in USA  
Specifications subject to change without notice.

[www.cla-val.com](http://www.cla-val.com)

Represented By:



— MODEL — **REPAIR KITS**

**Complete Replacement Diaphragm Assemblies for 100-01 and 100-20 Hytrol Main Valves**

**For:** Hytrol Main Valves with Ductile Iron, Bronze Trim Materials—**125/150 Pressure Class Only.**

**FACTORY ASSEMBLED**

Includes: Stem, Disc Guide, Disc, Disc Retainer, Spacer Washers, Diaphragm, Diaphragm Washer and Stem Nut.

Valve Size	Diaphragm Assembly Stock Number		Valve Size	Diaphragm Assembly Stock Number	
	100-01	100-20		100-01	100-20
3/8" (Also 81-01)	49097K	N/A	6"	40456G	33273E
1/2" - 3/4" (Also 81-01)	C2518D	N/A	8"	45276D	40456G
1"	C2520K	N/A	10"	81752J	45276D
1 1/4"-1 1/2"	C2522 F	N/A	12"	85533J	81752J
2"	C2524B	N/A	14"	89067D	N/A
2 1/2"	C2523D	N/A	16"	89068B	85533J
3"	C2525J	C2524B	20"	N/A	89068B
4"	33273E	C2525J	24"	N/A	89068B

**Repair Kits for 100-01/100-20 Hytrol Valves**

**For:** Hytrol Main Valves—**125/150 Pressure Class Only.**

Supplied Shrink Wrapped (4" and smaller) or Bagged (6" and larger)

Includes: Diaphragm, Disc (or Disc Assembly) and spare Spacer Washers.

Buna-N® Standard Material				Viton (For KB Valves)			
Valve Size	Repair Kit Stock Number		Valve Size	Repair Kit Stock Number			
	100-01	100-20		100-01	100-20		
3/8" (Also 81-01)	9169801K	N/A	3/8" (Also 81-01)	9169806J	N/A		
1/2" - 3/4" (Also 81-01)	9169802H	N/A	1/2" - 3/4" (Also 81-01)	9169807G	N/A		
1"	9169803F	N/A	1"	9169808E	N/A		
1 1/4" - 1 1/2"	9169804D	N/A	1 1/4" - 1 1/2"	9169809C	N/A		
2"	9169805A	N/A	2"	9169810A	N/A		
2 1/2"	9169811J	N/A	2 1/2"	9169817F	N/A		
3"	9169812G	9169805A	3"	9169818D	9169810A		
4"	9169813E	9169812G	4"	9169819B	9169818D		
6"	9169815K	9169813E	6"	9169820K	9169819B		
8"	9817901D	9169815K	8"	N/A	9169820K		
10"	9817902B	9817901D					
12"	9817903K	9817902B					
14"	9817904H	N/A					
16"	9817905E	9817903K					
20"	N/A	9817905E					
24"	N/A	9817905E					

When ordering, please give complete nameplate data of the valve and/or control being repaired.  
**MINIMUM ORDER CHARGE APPLIES.**

## Repair Kits for 100-02/100-21 Powertrol and 100-03/100-22 Powercheck Main Valves

**For:** Powertrol and Powercheck Main Valves—125/150 Pressure Class Only

Supplied Shrink Wrapped (4" and Smaller) or Bagged (6" and larger)

Includes: Diaphragm, Disc (or Disc Assembly) and spare Spacer Washers.

Valve Size	Kit Stock Number		Valve Size	Kit Stock Number	
	100-02			100-02 & 100-03	100-21 & 100-22
3/8"	9169901H		2 1/2"	9169910J	N/A
1/2" - 3/4"	9169902F		3"	9169911G	9169905J
1"	9169903D		4"	9169912E	9169911G
1 1/4" & 1 1/2"	9169904B		6"	9169913C	9169912E
2"	9169905J		8"	99116G	9169913C
			10"	N/A	99116G

Larger Sizes: Consult Factory.

## Repair Kits for 100-04/100-23 Hy-Check Main Valves

**For:** Hy-Check Main Valves—125/150 Pressure Class Only

Supplied Shrink Wrapped (4" and Smaller) or Bagged (6" and larger)

Includes: Diaphragm, Disc and O-Rings and full set of spare Spacer Washers.

Valve Size	Kit Stock Number		Valve Size	Kit Stock Number	
	100-04	100-23		100-04	100-23
4"	20210901B	N/A	12"	20210905H	20210904J
6"	20210902A	20210901B	14"	20210906G	N/A
8"	20210903K	20210902A	16"	20210907F	20210905H
10"	20210904J	20210903K	20", 24"	N/A	20210907F

Larger Sizes: Consult Factory.

## Repair Kits for Pilot Control Valves

Supplied Shrink Wrapped Includes: Diaphragm, Disc (or Disc Assembly), O-Rings, Gaskets or spare Screws as appropriate.

BUNA-N® (Standard Material)				VITON (For KB Controls)	
Pilot Control	Kit Stock Number	Pilot Control	Kit Stock Number	Pilot Control	Kit Stock Number
CDB	9170006C	CFM-7 & 7-A	1263901K	CDB-KB	9170012A
CDB-7	9170017K	CRA (w/bucking spring)	9170001D	CRA-KB	9170018H
CDH-2	18225D	CRD (w/bucking spring)	9170002B	CRD-KB (w/bucking spring)	9170008J
CDHS-2	44607A	CRD (no bucking spring)	9170003K	CRL-KB	9170013J
CDHS-2B	9170004H	CRD-22	98923G	CDHS-2BKB	9170010E
CDHS-2F	9170005E	CRL (55F, 55L)	9170007A	CDHS-2FKB	9170011C
CDHS-3C-A2	24657K	CRL-4A	43413E	CDHS-18KB (no bucking spring)	9170009G
CDHS-8A	2666901A	CRL-5 (55B)	65755B	102C-KB	1726202D
CDHS-18	9170003K	CRL-5A (55G)	20666E	Buna-N®	
CDS-4	9170014G	CV	9170019F	CRD DISC RET. (SOLID)	C5256H
CDS-5	14200A	X105L (O-ring)	00951E	CRD DISC RET. (SPRING)	C5255K
CDS-6	20119301A	102B-1	1502201F		
CFM-2, CFM-9, CFCM-M1	12223E	102C-2 & -3	1726201F		

## Repair Assemblies (In Standard Materials Only)

Control	Description	Stock Number
CF1-C1	Pilot Assembly Only	89541H
CF1-CI	Complete Float Control less Ball & Rod	89016A
CFC2-C1	Disc, Distributor & Seals	2674701E
CSM 11-A2-2	Mechanical Parts Assy.	97544B
CSM 11-A2-2	Pilot Assembly Only	18053K
33A 1"	Complete Internal Assembly & Seal	2036030B
33A 2"	Complete Internal Assembly & Seal	2040830J

When ordering, please give complete nameplate data of the valve and/or control being repaired. MINIMUM ORDER CHARGE APPLIES