

Hy-Check Valve

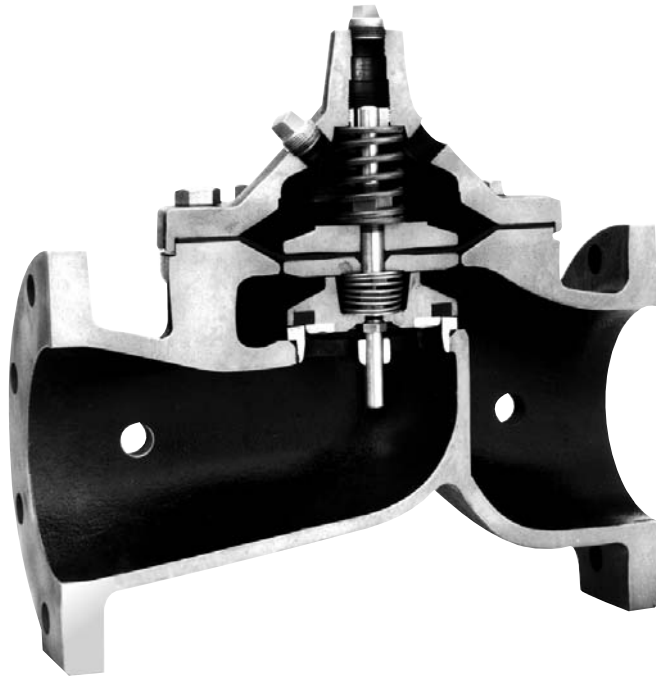

- **Built-in Automatic Check Valve**
- **Improved Flow Characteristics**
- **Drip Tight, Positive Seating**
- **Globe or Angle Pattern**
- **Packless Construction**

The Cla-Val Model 100-23 Hy-Check Valve is a hydraulically operated diaphragm valve with a built-in check feature to prevent return flow. Available in a globe or angle pattern, it consists of three parts: body, cover and diaphragm assembly. The only moving part is the diaphragm assembly which is guided top and bottom by a precision machined stem.

When operating pressure is applied above the non-wicking diaphragm, a synthetic rubber disc retained on three and one-half sides forms a drip-tight seal with the renewable seat. When pressure above the diaphragm is relieved the valve opens wide. The rate of closing or opening can be controlled by modulating the flow into or out of the diaphragm chamber. When a pressure reversal occurs the split valve stem will allow the disc retainer assembly to check closed **regardless of the position of the diaphragm.**

The Model 100-23 is used on system applications requiring remote control, pressure regulation, solenoid control, rate of flow control, liquid level control, or wherever a positive check feature is necessary to prevent reverse flow.

Principle of Operation

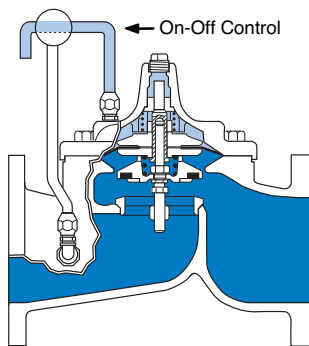

Full Open Operation

When pressure in the cover chamber is relieved to a zone of lower pressure, the line pressure at the valve inlet opens the valve, allowing full flow.

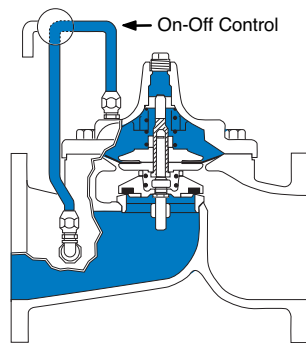

Tight Closing Operation

When pressure from the valve inlet is applied to the cover chamber, the valve closes drip-tight.

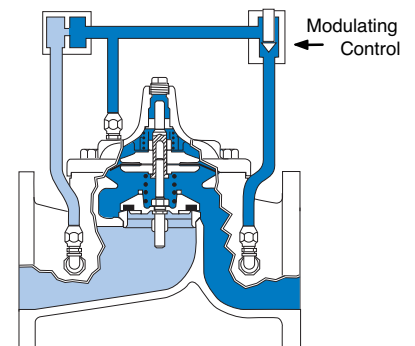

Check Action

When a static condition or pressure reversal occurs, the split stem design allows the valve to instantly check closed. Return flow is prevented regardless of the diaphragm's position.

Note: For optimum operation of built-in check feature, installation with stem vertically up is recommended.

Specifications

Available Sizes

Pattern	Flanged
Globe	3, 4, 6", 8", 10", 12", 14", 16", 18", 20", 24"
Angle	6", 8"

Operating Temp. Range

Fluids
-40° to 180° F

Pressure Ratings (Recommended Maximum Pressure - psi)

Valve Body & Cover		Pressure Class		
		Flanged		
Grade	Material	ANSI Standards*	150 Class	300 Class
ASTM A536	Ductile Iron	B16.42	250	400
ASTM A216-WCB	Cast Steel	B16.5	285	400
ASTM B62	Bronze	B16.24	225	400

Note: * ANSI standards are for flange dimensions only.
Flanged valves are available faced but not drilled.
Valves for higher pressure are available; consult factory for details

Materials

Component	Standard Material Combinations		
Body & Cover	Ductile Iron	Cast Steel	Bronze
Available Sizes	3" - 24"	3" - 16"	3" - 16"
Disc Retainer & Diaphragm Washer	Cast Iron	Cast Steel	Bronze
Trim: Disc Guide, Seat & Cover Bearing	Bronze is Standard Stainless Steel is optional		
Disc	Buna-N® Rubber		
Diaphragm	Nylon Reinforced Buna-N® Rubber		
Stem, Nut & Spring	Stainless Steel		

For material options on sizes not listed, consult factory.
Cla-Val manufactures valves in more than 50 different alloys.

Options

Epoxy Coating - suffix KC

This option NSF 61 Listed and FDA approved, fusion bonded epoxy coating is for use with cast iron, ductile iron or steel valves. This coating is resistant to various water conditions, certain acids, chemicals, solvents and alkalies. Epoxy coatings are applied in accordance with AWWA coating specifications C116-03. Do not use with temperatures above 175° F.

Viton® Rubber Parts - suffix KB

Optional diaphragm, disc and o-ring fabricated with Viton® synthetic rubber. Viton® is well suited for use with mineral acids, salt solutions, chlorinated hydrocarbons, and petroleum oils; and is primarily used in high temperature applications up to 250° F. Do not use with epoxy coating above 175°F.

For assistance in selecting appropriate valve options or valves manufactured with special design requirements, please contact our Regional Sales Office or Factory.



6" Globe, Flanged



6" Angle, Flanged



12" Globe, Flanged



20" Globe, Flanged

Functional Data

Model 100-23

Valve Size		Inches	3	4	6	8	10	12	14	16	18	20	24
		mm.	80	100	150	200	250	300	350	400	460	500	600
C_V Factor	Globe Pattern	Gal./Min. (gpm.)	62	136	229	480	930	1458	1725	2110	2940*	3400*	4020
		Litres/Sec. (l/s.)	15	32.5	55	115	223	350	414	506	705	816	965
	Angle Pattern	Gal./Min. (gpm.)	—	135	233	545	—	—	—	—	—	—	—
		Litres/Sec. (l/s.)	—	32	56	132	—	—	—	—	—	—	—
Equivalent Length of Pipe	Globe Pattern	Feet (ft.)	293	251	777	748	621	654	750	977	983	1125	3005
		Meters (m.)	89.3	76.4	237.1	228.1	189.5	199.4	228.7	298.1	299.9	343.2	916.6
	Angle Pattern	Feet (ft.)	—	254	751	580	—	—	—	—	—	—	—
		Meters (m.)	—	77.6	229	176.9	—	—	—	—	—	—	—
K Factor	Globe Pattern		20.6	12.7	23.1	15.7	10.4	8.5	8.9	10.2	8.4	8.8	19.1
	Angle Pattern		—	12.9	22.3	12.2	—	—	—	—	—	—	—
Liquid Displaced from Cover Chamber When Valve Opens		Fl. Oz	—	—	—	—	—	—	—	—	—	—	—
		U.S. Gal.	0.32	.08	.17	.53	1.26	2.51	4.0	4.0	9.6	9.6	9.6
		ml	—	—	—	—	—	—	—	—	—	—	—
		Litres	.12	.30	.64	2.0	4.8	9.5	15.1	15.1	36.2	36.2	36.2

*Estimated

C_V Factor

Formulas for computing C_V Factor, Flow (Q) and Pressure Drop (ΔP):

$$C_V = \frac{Q}{\sqrt{\Delta P}} \quad Q = C_V \sqrt{\Delta P} \quad \Delta P = \left(\frac{Q}{C_V} \right)^2$$

K Factor (Resistance Coefficient)

The Value of K is calculated from the formula: $K = \frac{894d^4}{C_V^2}$
(U.S. system units)

Equivalent Length of Pipe

Equivalent lengths of pipe (L) are determined from the formula: $L = \frac{Kd}{12f}$
(U.S. system units)

Fluid Velocity

Fluid velocity can be calculated from the following formula: $V = \frac{.4085 Q}{d^2}$
(U.S. system units)

Where:

C_V = U.S. (gpm) @ 1 psi differential at 60° F water
or

= (l/s) @ 1 bar (14.5 PSIG) differential
at 15° C water

d = inside pipe diameter of Schedule 40 Steel Pipe (inches)

f = friction factor for clean, new Schedule 40 pipe
(dimensionless) (from Cameron Hydraulic Data,
18th Edition, P 3-119)

K = Resistance Coefficient (calculated)

L = Equivalent Length of Pipe (feet)

Q = Flow Rate in U.S. (gpm) or (l/s)

V = Fluid Velocity (feet per second) or (meters per second)

ΔP = Pressure Drop in (psi) or (bar)

Model 100-23 Flow Chart (Based on normal flow through a wide open valve)

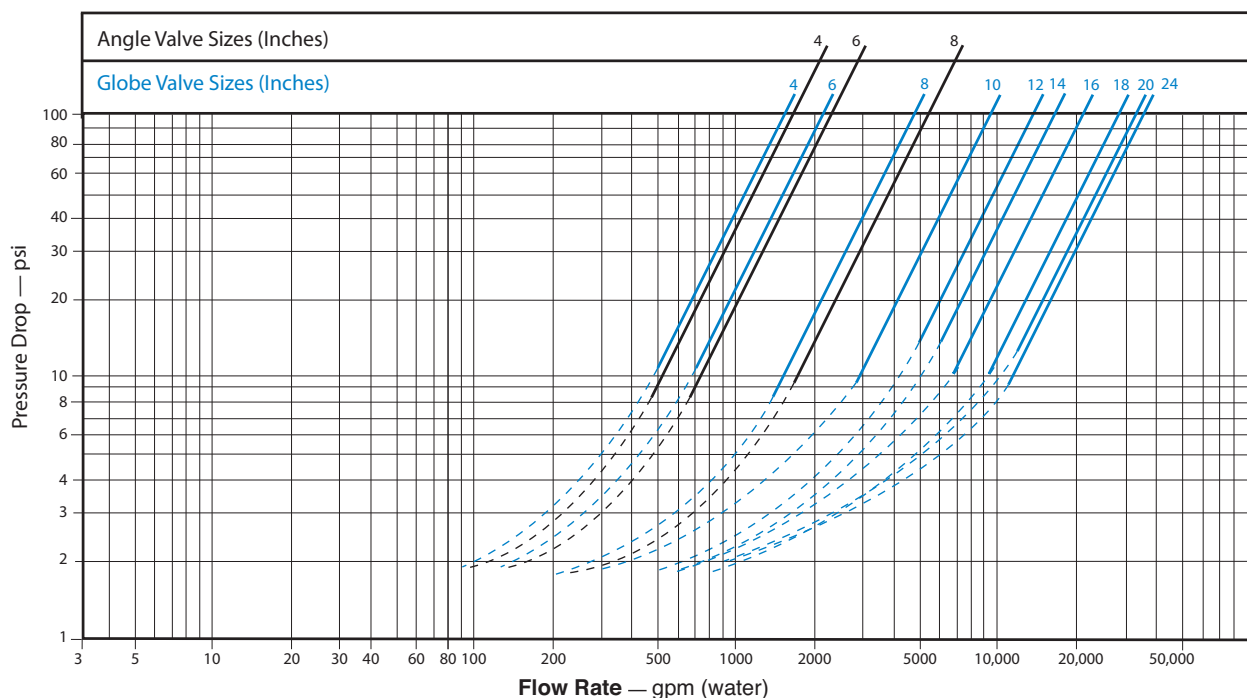

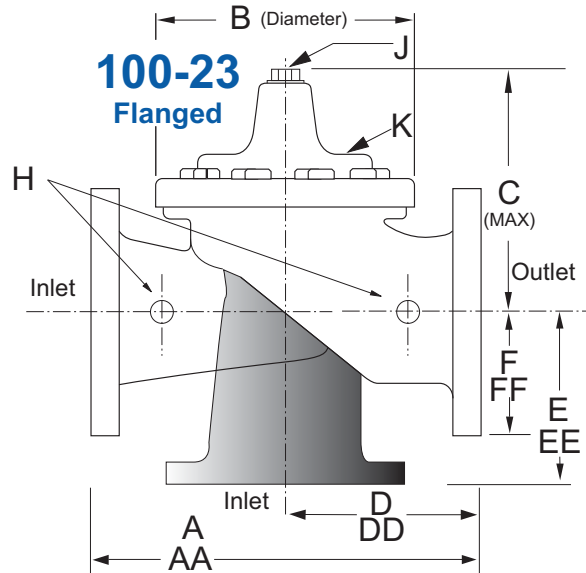

Valve Size (Inches)	3	4	6	8	10	12	14	16	18	20	24	30	36	42	48
A 150 ANSI	10.25	13.88	17.75	21.38	26.00	30.00	34.25	35.00	42.12	48.00	48.00	63.25	65.00	76.00	94.50
AA 300 ANSI	11.00	14.50	18.62	22.38	27.38	31.50	35.75	36.62	43.63	49.62	49.75	63.75	67.00	76.00	94.50
B Dia.	6.62	9.12	11.50	15.75	20.00	23.62	27.47	28.00	35.44	35.44	35.44	53.19	56.00	66.00	66.00
C Max.	7.00	8.62	11.62	15.00	17.88	21.00	20.88	25.75	25.00	31.50	31.50	43.94	54.60	61.50	61.50
D 150 ANSI	—	6.94	8.88	10.69	—	—	—	—	—	—	—	—	—	—	—
DD 300 ANSI	—	7.25	9.38	11.19	—	—	—	—	—	—	—	—	—	—	—
E 150 ANSI	—	5.50	6.75	7.25	—	—	—	—	—	—	—	—	—	—	—
EE 300 ANSI	—	5.81	7.25	7.75	—	—	—	—	—	—	—	—	—	—	—
F 150 ANSI	3.75	4.50	5.50	6.75	8.00	9.50	11.00	11.75	15.88	14.56	17.00	19.88	25.50	28.00	31.50
FF 300 ANSI	4.12	5.00	6.25	7.50	8.75	10.25	—	12.75	15.88	16.06	19.00	22.00	27.50	28.00	31.50
H NPT Body Tapping	.375	.50	.75	.75	1	1	1	1	1	1	1	1	2	2	2
J NPT Cover Center Plug	.50	.50	.75	.75	1	1	1.25	1.25	2	2	2	2	2	2	2
K NPT Cover Tapping	.375	.50	.75	.75	1	1	1	1	1	1	1	1	2	2	2
Valve Stem Internal Thread UNF	10-32	¼-28	¼-28	¾-24	¾-24	¾-24	¾-24	¾-24	½-20	½-20	½-20	¾-16	¾-16	M20	M20
Stem Travel	0.6	0.8	1.1	1.7	2.3	2.8	3.4	3.4	3.4	4.5	4.5	6.5	7.5	8.5	8.5
Approx. Ship Wt. Lbs.	45	85	195	330	625	900	1250	1380	2365	2551	2733	6500	8545	12450	13100

Note: The top two flange holes on valve sizes 36 thru 48 are threaded to 1 1/2"-6 UNC.

Valve Size (mm)	80	100	150	200	250	300	350	400	450	500	600	750	900	1000	1200
A 150 ANSI	260	353	451	543	660	762	870	889	1070	1219	1219	1607	1651	1930	2400
AA 300 ANSI	279	368	473	568	695	800	908	930	1108	1260	1263	1619	1702	1930	2400
B Dia.	168	232	292	400	508	600	698	711	900	900	900	1351	1422	1676	1676
C Max.	178	219	295	381	454	533	530	654	635	800	800	1116	1387	1562	1562
D 150 ANSI	—	176	226	272	CF*	CF*	CF*	CF*	CF*	CF*	CF*	—	—	—	—
DD 300 ANSI	—	184	238	284	CF*	CF*	CF*	CF*	CF*	CF*	CF*	—	—	—	—
E 150 ANSI	—	140	171	184	CF*	CF*	CF*	CF*	CF*	CF*	CF*	—	—	—	—
EE 300 ANSI	—	148	184	197	CF*	CF*	CF*	CF*	CF*	CF*	CF*	—	—	—	—
F 150 ANSI	95	114	140	171	203	241	279	298	403	370	432	505	648	711	800
FF 300 ANSI	105	127	159	191	222	260	—	324	403	408	483	559	699	711	800
H NPT Body Tapping	.375	.50	.75	.75	1	1	1	1	1	1	1	1	2	2	2
J NPT Cover Center Plug	.50	.50	.75	.75	1	1	1.25	1.25	2	2	2	2	2	2	2
K NPT Cover Tapping	.375	.50	.75	.75	1	1	1	1	1	1	1	1	2	2	2
Valve Stem Internal Thread UNF	10-32	¼-28	¼-28	¾-24	¾-24	¾-24	¾-24	¾-24	½-20	½-20	½-20	¾-16	¾-16	M20	M20
Stem Travel	15	20	28	43	58	71	86	86	86	114	114	165	191	216	216
Approx. Ship Wt. Kgs.	20	39	89	150	284	409	568	627	681	1157	1249	2951	3876	5647	5942

For assistance in selecting appropriate valve options or valves manufactured with special design requirements, please contact our Regional Sales Office or Factory.

Cla-Val Control Valves operate with maximum efficiency when mounted in horizontal piping with the main valve cover UP, however, other positions are acceptable. Due to component size and weight of 10 inch and larger valves, installation with cover UP is advisable. We recommend isolation valves be installed on inlet and outlet for maintenance. Adequate space above and around the valve for service personnel should be considered essential. A regular maintenance program should be established based on the specific application data. However, we recommend a thorough inspection be done at least once a year. Consult factory for specific recommendations.