

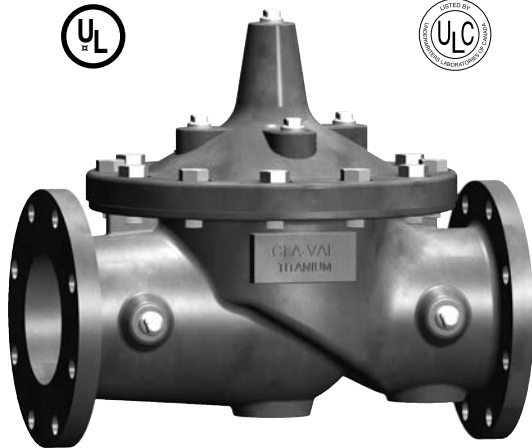

MODEL

Ti 100GS Seawater Version

Titanium Deluge Valve



- U.L. Listed / U.L.C. Listed
- Globe Pattern
- Proven Reliable Design

The Cla-Val Model Ti 100GS Deluge Valve is designed for use in controlling water flow to Deluge, Pre-Action, or Foam-Water type fire protection sprinkler systems. This valve is U.L. Listed in "Special Systems Water Control Valves Class I (VLFT)". The Model Ti 100GS is a hydraulically-operated, diaphragm-actuated, globe or angle pattern Deluge Valve. It consists of three major components: the body, the cover, and the diaphragm assembly. The only moving part is the diaphragm assembly. Packless construction and simplicity of design assures long service life and dependable low maintenance for this valve.

The Ti 100GS are manufactured in materials suitable for seawater.

Typical Application

The Model Ti 100GS is installed to control the water flow to the sprinklers in Deluge, Pre-Action, or Foam-Water type systems. A simplified system is used to illustrate typical operation. The Model Ti 100GS Deluge Valve (3) is maintained in the closed position by means of system water pressure controlled by a pilot control (4). When the pilot control valve receives a signal from the fire detection system, it allows the deluge valve to open. Firefighting water (1) then enters system piping (5) and discharges from sprinklers (6).

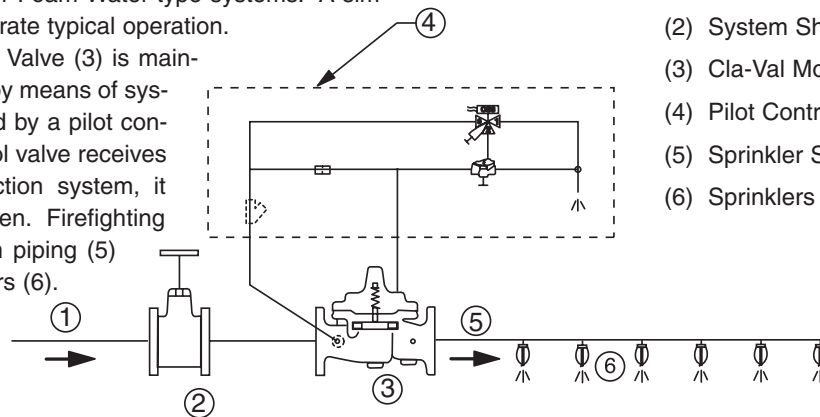

- (1) From System Water Supply
- (2) System Shut-off Valve (Visual Stem)
- (3) Cla-Val Model Ti 100GS
- (4) Pilot Control System
- (5) Sprinkler System Piping
- (6) Sprinklers

Specifications

Sizes:	Globe: 3" - 4" - 6"
End Details:	ISO 7005-2 PN 10-16 150 ANSI B16.42 flanged
Pressure Rating:	26 bar max.
Temperature Range:	Water, to 180°F MAX.
Material:	Main Valve Body & Cover Titanium ASTM B367 Grade C2 Standard Main Valve Trim: Titanium ASTM B367, Grade C2 Diaphragm and Disc: Buna-N, synthetic rubber

Friction Loss

For use in hydraulically calculated systems, friction loss equivalent to:

Ti 100GS (Globe):

- 3" Size=42 Ft. of 3" Pipe
- 4" Size=92 Ft. of 4" Pipe
- 6" Size=116 Ft. of 6" Pipe

When Ordering, Please Specify

- | | |
|-------------------------|---------------------------|
| 1. Catalog No. Ti 100GS | 2. Size |
| 3. Pressure Class | 4. Internal Trim Material |

Specifications Ti 100GS Seawater Service Option

Sizes Globe: 3" - 4" - 6" flanged

"Fluid Control at It's Best"



To calculate the maximum wet sprinkler pilot height above the valve, use the graph below.

CLA-VAL Ti 100GS
WET PILOT LINE DESIGN CRITERIA
 For All Valve Sizes

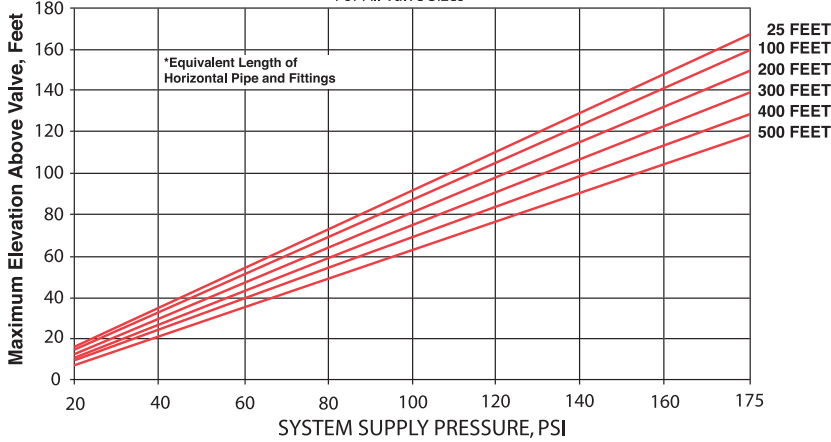

*Based on 1/2 inch schedule 40 pipe, C=120
 If system supply pressure is variable, use minimum value

WET PILOT LINE EQUIVALENT LENGTHS MUST BE RECALCULATED FOR SYSTEMS USING PILOT LINE SIZES AND FITTINGS OTHER THAN THAT SPECIFIED IN THE ABOVE GRAPH

Functional Data

Valve Size		Inches	3	4	6
		mm	80	100	150
Cv Factor	Globe Pattern	Gal./Min. (gpm)	115	200	440
		Litres/Sec. (l/s)	27.6	48	105.6

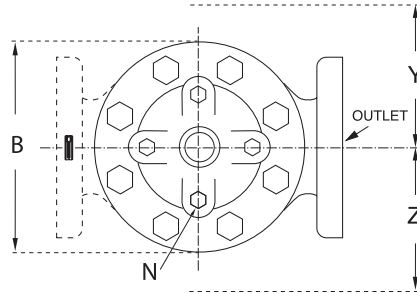
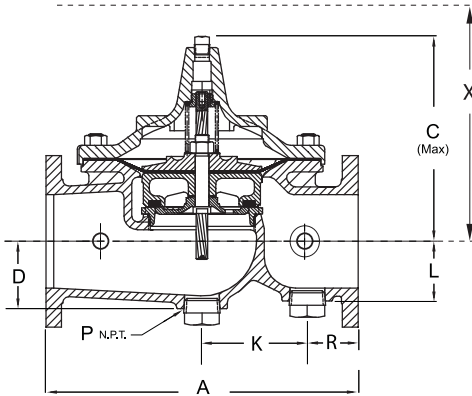

Valve Size (Inches)	3	4	6
A 150 ANSI	12.00	15.00	20.00
B Dia.	9.12	11.50	15.75
C Max.	8.19	10.62	13.38
D	2.56	3.19	4.31
K	7.00	4.03	6.75
L	2.56	2.81	3.81
N NPT	1/2"-14	3/4"-14	3/4"-14
P NPT	1 1/4"-11 1/2	2"-11 1/2"	2"-11 1/2"
R 150 ANSI	2.50	3.47	3.25
X Pilot System	15.00	17.00	29.00
Y Pilot System	11.00	12.00	20.00
Z Pilot System	11.00	12.00	20.00

Valve Size (mm)	80	100	150
A 150 ANSI	305	381	508
B Dia.	232	292	400
C Max.	208	270	340
D	65	81	110
K	178	102	171
L	65	71	97
N NPT	1/2"-14	3/4"-14	3/4"-14
P NPT	1 1/4"-11 1/2	2"-11 1/2"	2"-11 1/2"
R 150 ANSI	64	88	83
X Pilot System	381	432	737
Y Pilot System	279	305	508
Z Pilot System	279	305	508



CLA-VAL

PO Box 1325 Newport Beach CA 92659-0325 • Phone: 949-722-4800
 Fax: 949-548-5441 • Web Site: cla-val.com • E-mail: claval@cla-val.com

CLA-VAL CANADA

4687 Christie Drive
 Beamsville, Ontario
 Canada L0R 1B4
 Phone: 905-563-4963
 Fax: 905-563-4040
 E-Mail: sales@cla-val.ca

CLA-VAL EUROPE

Chemin des Mésanges 1
 CH-1032 Romanell/
 Lausanne, Switzerland
 Phone: 41-21-643-15-55
 Fax: 41-21-643-15-50
 E-Mail: cla-val@cla-val.ch

CLA-VAL UK

Dainton House, Goods Station Road
 GB - Tunbridge Wells
 Kent TN1 2 DH England
 Phone: 44-1892-514-400
 Fax: 44-1892-543-423
 E-Mail: info@cla-val.co.uk

Represented By: