

Modulating Float Valve



- **Accurate Level Control**
- **Completely Automatic Operation**
- **Simple Operation**
- **Drip-Tight Shut-Off**
- **Easy Installation and Maintenance**

The Cla-Val Model 428-01/628-01 Float Valve modulates to maintain a constant liquid level in a storage tank by compensating for variations in supply or demand. It can be installed to control the flow into or out of the tank by either closing on a rising level or opening on a rising level. This valve is a hydraulically operated, pilot controlled diaphragm valve.

The pilot control system consists of an integral variable orifice in the main valve cover and a remotely mounted float control. A slight change in liquid level moves the float control. This action varies the pressure in the valve cover, causing the main valve to seek a new position. The integral variable orifice automatically regulates the flow into the cover chamber until the valve reaches a position that is in direct relation to the position of the float control.

Schematic Diagram

Item	Description
1	Hytrol Main Valve
2	CFM-9 Float Control
3	CK2 (Isolation Valve)

Optional Features

Item	Description
A	X46A Flow Clean Strainer
D	Check Valves with Isolation Valve
C	CV Speed Control
F	Independent Operating Pressure
P	X141 Pressure Gauge
S	CV Speed Control
Y	X43 "Y" Strainer

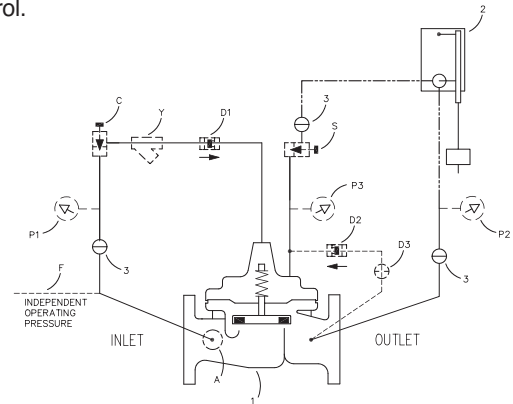

Installation Data

The valve may be installed in any position. The remote float control may be mounted at any convenient location above the liquid level. Float rods are available in lengths from 2' to 12' in one-foot increments.

A stilling well (8" min. diameter) should be provided around the float if the liquid surface is subject to turbulence, ripples or wind.

The float control may be installed at any elevation above the valve providing that the amount of flowing line pressure (in psi) is equal to or greater than the vertical distance in feet between the valve and the float control.

When a separate source of supply pressure (Option F) is used by the pilot control system, that pressure must at all times be constant and equal to or greater than the pressure at the valve inlet.

DO NOT USE FOR ON-OFF SERVICE.

Note: We recommend protecting tubing and valve from freezing temperatures.

Typical Applications

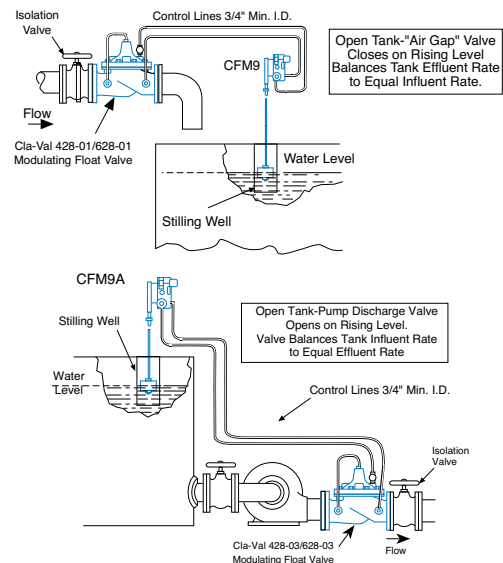

Model 428-01 (Uses Basic Valve Model 100-32)

Pressure Ratings (Recommended Maximum Pressure - psi)

Valve Body & Cover		Pressure Class				
		Flanged		Grooved	Threaded	
Grade	Material	ANSI Standards*	150 Class	300 Class	300 Class	End‡ Details
ASTM A536	Ductile Iron	B16.42	250	400	400	400
ASTM A216-WCB	Cast Steel	B16.5	285	400	400	400
ASTM B62	Bronze	B16.24	225	400	400	400

Note: * ANSI standards are for flange dimensions only.
 Flanged valves are available faced but not drilled.
 ‡ End Details machined to ANSI B2.1 specifications.
Valves for higher pressure are available; consult factory for details

Materials

Component	Standard Material Combinations		
Body & Cover	Ductile Iron	Cast Steel	Bronze
Available Sizes	1" - 6"	1" - 6"	1" - 6"
Disc Retainer & Diaphragm Washer	Cast Iron	Cast Steel	Bronze
Trim: Disc Guide, Seat & Cover Bearing	Bronze is Standard Stainless Steel is Optional		
Disc	Buna-N® Rubber		
Diaphragm	Nylon Reinforced Buna-N® Rubber		
Stem, Nut & Spring	Stainless Steel		

For material options not listed, consult factory.
 Cla-Val manufactures valves in more than 50 different alloys.

Dimensions
(In inches)

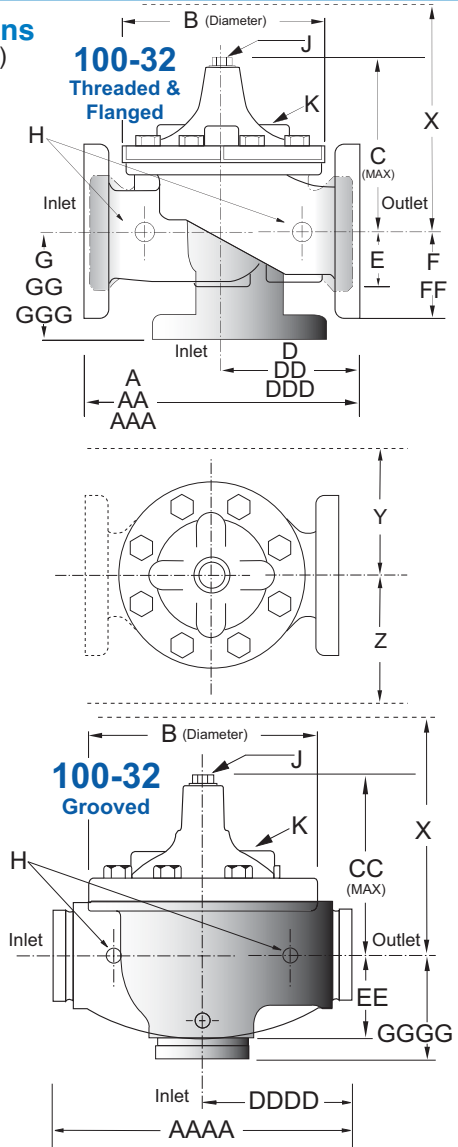

Model 428-01 Dimensions (In Inches)

Valve Size (Inches)	1	1 1/4	1 1/2	2	2 1/2	3	4	6
A Threaded	7.25	7.25	7.25	9.38	11.00	12.50	—	—
AA 150 ANSI	—	—	8.50	9.38	11.00	12.00	15.00	20.00
AAA 300 ANSI	—	—	9.00	10.00	11.62	13.25	15.62	21.00
AAAA Grooved End	—	—	8.50	9.00	11.00	12.50	15.00	20.00
B Dia.	5.62	5.62	5.62	6.62	8.00	9.12	11.50	15.75
C Max.	5.50	5.50	5.50	6.50	7.56	8.19	10.62	13.38
CC Max. Grooved End	—	—	4.75	5.75	6.88	7.25	9.31	12.12
D Threaded	3.25	3.25	3.25	4.75	5.50	6.25	—	—
DD 150 ANSI	—	—	4.00	4.75	5.50	6.00	7.50	10.00
DDD 300 ANSI	—	—	4.25	5.00	5.88	6.38	7.88	10.50
DDDD Grooved End	—	—	—	4.75	—	6.00	7.50	—
E	1.12	1.12	1.12	1.50	1.69	2.06	3.19	4.31
EE Grooved End	—	—	2.00	2.50	2.88	3.12	4.25	6.00
F 150 ANSI	—	—	2.50	3.00	3.50	3.75	4.50	5.50
FF 300 ANSI	—	—	3.06	3.25	3.75	4.13	5.00	6.25
G Threaded	1.88	1.88	1.88	3.25	4.00	4.50	—	—
GG 150 ANSI	—	—	4.00	3.25	4.00	4.00	5.00	6.00
GGG 300 ANSI	—	—	4.25	3.50	4.31	4.38	5.31	6.50
GGGG Grooved End	—	—	—	3.25	—	4.25	5.00	—
H NPT Body Tapping	.375	.375	.375	.375	.50	.50	.75	.75
J NPT Cover Center Plug	.25	.25	.25	.50	.50	.50	.75	.75
K NPT Cover Tapping	.375	.375	.375	.375	.50	.50	.75	.75
Stem Travel	0.4	0.4	0.4	0.6	0.7	0.8	1.1	1.7
Approx. Ship Wt. Lbs.	15	15	15	35	50	70	140	285
X Pilot System	11	11	11	13	14	15	17	29
Y Pilot System	9	9	9	9	10	11	12	20
Z Pilot System	9	9	9	9	10	11	12	20

Model 628-01 (Uses Basic Valve Model 100-33)

Dimensions
(In inches)

Pressure Ratings (Recommended Maximum Pressure - psi)

Valve Body & Cover		Pressure Class		
		Flanged		
Grade	Material	ANSI Standards*	150 Class	300 Class
ASTM A536	Ductile Iron	B16.42	250	400
ASTM A216-WCB	Cast Steel	B16.5	285	400
ASTM B62	Bronze	B16.24	225	400

Note: * ANSI standards are for flange dimensions only.
Flanged valves are available faced but not drilled.
Valves for higher pressure are available; consult factory for details

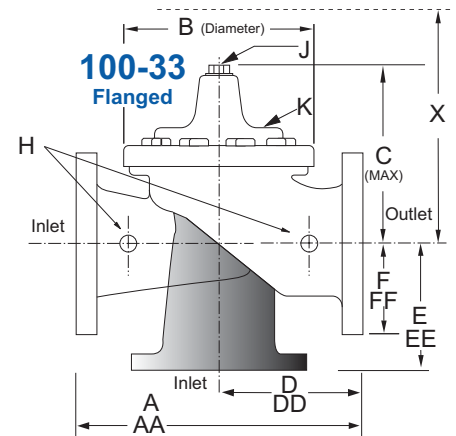

Materials

Component	Standard Material Combinations		
Body & Cover	Ductile Iron	Cast Steel	Bronze
Available Sizes	3" - 8"	3" - 8"	3" - 8"
Disc Retainer & Diaphragm Washer	Cast Iron	Cast Steel	Bronze
Trim: Disc Guide, Seat & Cover Bearing	Bronze is Standard Stainless Steel is Optional		
Disc	Buna-N® Rubber		
Diaphragm	Nylon Reinforced Buna-N® Rubber		
Stem, Nut & Spring	Stainless Steel		

For material options not listed, consult factory.
Cla-Val manufactures valves in more than 50 different alloys.

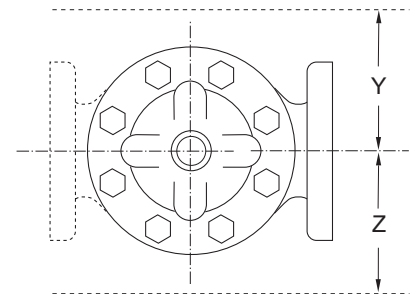

Model 628-01 Dimensions (In Inches)

Valve Size (Inches)	3	4	6	8
A 150 ANSI	10.25	13.88	17.75	21.38
AA 300 ANSI	11.00	14.50	18.62	22.38
B Dia.	6.62	9.12	11.50	15.75
C Max.	7.00	8.62	11.62	15.00
D 150 ANSI	—	6.94	8.88	10.69
DD 300 ANSI	—	7.25	9.38	11.19
E 150 ANSI	—	5.50	6.75	7.25
EE 300 ANSI	—	5.81	7.25	7.75
F 150 ANSI	3.75	4.50	5.50	6.75
FF 300 ANSI	4.12	5.00	6.25	7.50
H NPT Body Tapping	.375	.50	.75	.75
J NPT Cover Center Plug	.50	.50	.75	.75
K NPT Cover Tapping	.375	.50	.75	.75
Stem Travel	0.6	0.8	1.1	1.7
Approx. Ship Wt. Lbs.	45	85	195	330
X Pilot System	13	15	27	30
Y Pilot System	10	11	18	20
Z Pilot System	10	11	18	20

428-01 Valve Selection	100-32 Pattern: Globe (G), Angle (A), End Connections: Threaded (T), Grooved (GR), Flanged (F) Indicate Available Sizes									
	Inches	1	1¼	1½	2	2½	3	4	6	8
	mm	25	32	40	50	65	80	100	150	200
Basic Valve 100-32	Pattern	G, A	G, A	G, A	G, A	G, A	G, A	G, A	G, A	G, A
	End Detail	T	T	T, F, Gr*	T, F, Gr	T, F, Gr*	T, F, Gr	F, Gr	F, Gr*	F, Gr*
Suggested Flow (gpm)	Maximum	55	93	125	210	300	460	800	1800	3100
	Maximum Intermittent	68	120	160	260	370	580	990	2250	3900
Suggested Flow (Liters/Sec)	Maximum	3.5	6	8	13	19	29	50	113	195
	Maximum Intermittent	4.3	7.6	10	16	23	37	62	142	246

100-32 Series is the full internal port Hytrol. *Globe Grooved Only

627-01 Valve Selection	100-33 Pattern: Globe (G), Angle (A), End Connections: Flanged (F) Indicate Available Sizes					
	Inches	3	4	6	8	10
	mm	80	100	150	200	250
Basic Valve 100-33	Pattern	G	G, A	G, A	G, A	G
	End Detail	F	F	F	F	F
Suggested Flow (gpm)	Maximum	260	580	1025	2300	4100
Suggested Flow (Liters/Sec)	Maximum	16	37	65	145	258

100-33 Series is the reduced internal port size version of the 100-32 Series.

Important Notice: Do Not Oversize

**Pilot System
Specifications**

Temperature Range
Water: to 180°F

Materials:

In contact with operating fluid: Bronze, Stainless Steel, Monel, with Buna-N® Rubber seals.
 Float linkage: Brass, PVC
 Base plate: Enameled Steel
 Float: 304 Stainless Steel
 Float Rod: Standard - Two 12" sections of PVC rod, with 12" extension increments.

Float Rod: Optional - 24" stainless steel rod, with 24" extension increments.

A larger counterweight is required if float rod length exceeds 4'. Consult factory for details.

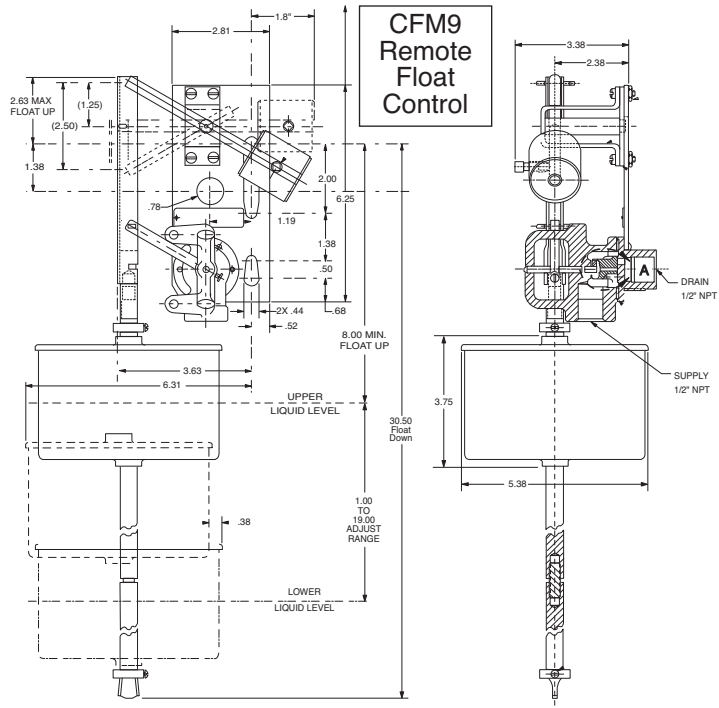

**When Ordering,
Please Specify**

1. Catalog No. 428-01 or No. 628-01
2. Valve Size
3. Pattern - Globe or Angle
4. Pressure Class
5. Materials Desired
6. Threaded or Flanged
7. Valve Closing or Valve Opening on Rising Water Level
8. Desired Options