



550-01
(Full Internal Port)
MODEL
6550-01
(Reduced Internal Port)

Pressure Relief, Pressure Sustaining Valve



- **Accurate Pressure Control**
- **Optional Check Feature**
- **Fast Opening – maintains line pressure**
- **Slow Closing – prevents surges**
- **Completely Automatic Operation**

The Cla-Val Model 550-01 Pressure Relief Valve is a hydraulically operated, pilot-controlled, modulating valve designed to maintain constant upstream pressure within close limits. This valve can be used for pressure relief, pressure sustaining, back pressure, or unloading functions in a by-pass system.

In operation, the valve is actuated by line pressure through a pilot control system, opening fast to maintain steady line pressure but closing gradually to prevent surges. Operation is completely automatic and pressure settings may be easily changed.

If the optional check feature "D" is added, and a pressure reversal occurs, the valve closes to prevent return flow.

Schematic Diagram

Item	Description
1	Hytrol (100-46 Main Valve - Full Internal Port) Hytrol (100-44 Main Valve - Reduced Internal Port)
2	X42N-2 Strainer & Needle Valve
3	CRL Pressure Relief Control

Optional Features

Item	Description
B	CK2 (Isolation Valve)
D	Check Valves with Isolation Valve
F	Remote Pilot Sensing
P	X141 Pressure Gauge
S	CV Speed Control (Opening)
V	X101 Valve Position Indicator

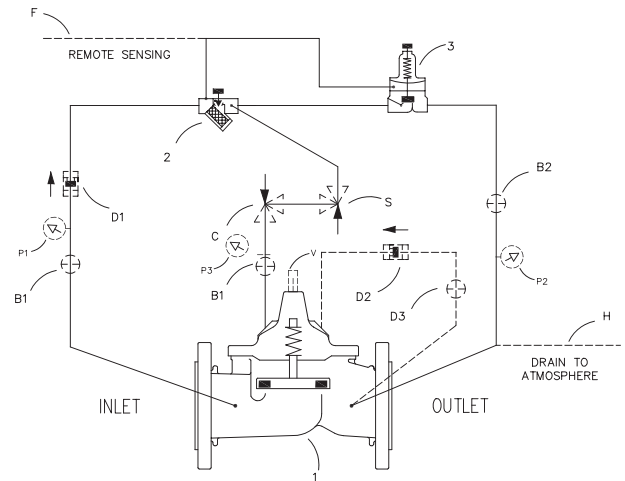

The "D" feature on a vertically installed 6" and larger valve must be horizontally oriented.

Typical Applications

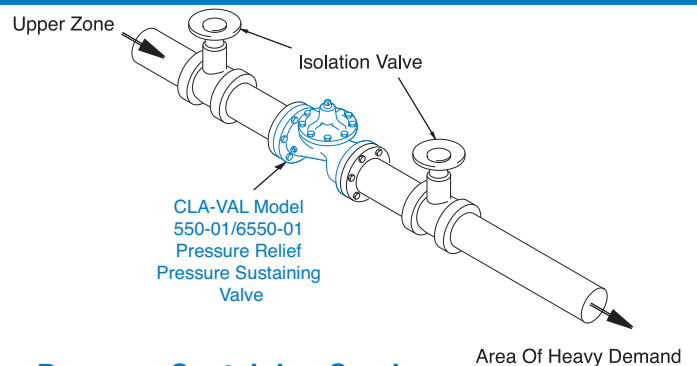
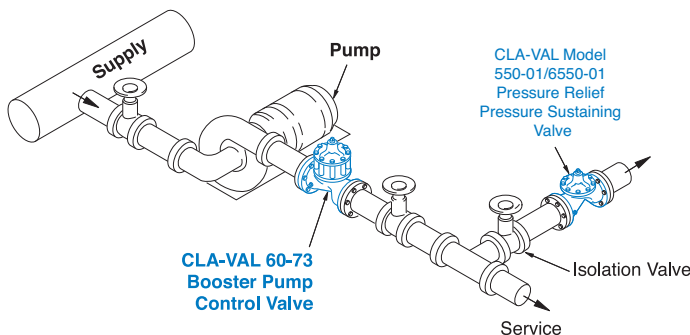

Pressure Relief Service

To provide protection for the system against high pressure surges when pumps are shut down, this fast opening – slow closing relief valve dissipates the excess pressure.

Pressure Sustaining Service

When installed in a line between an upper zone and a lower area of heavy demand, the valve acts to maintain desired upstream pressure to prevent "robbing" of the upper zone. Water in excess of pressure setting flows to area of heavy demand; control is smooth, and pressure regulation is positive.



Specifications

Sizes

Globe (inch):
1½", 2", 2-1/2", 3", 4", 6"

End Detail

Slip-on Two Piece Flange
Dimensions Per ANSI B16.5

Pressure Rating

ANSI Class 150:
Maximum 285 psi
ANSI Class 300:
Maximum 400 psi

Higher Pressure Available
Please Contact Factory

Operating Temperature

Fluids Compatible with Valve
Materials
-40° to 180° F (-40° to 82° C)

Materials

Body, Cover, Trim,
Diaphragm Assembly,
Flanges, and Fasteners
316 Series
Stainless Steel
Electropolished

Disc:

Buna-N® Rubber*

Diaphragm:

Nylon Fabric Reinforced
Synthetic Buna-N® Rubber*

*Contact Factory for Other
Disc or Diaphragm Materials

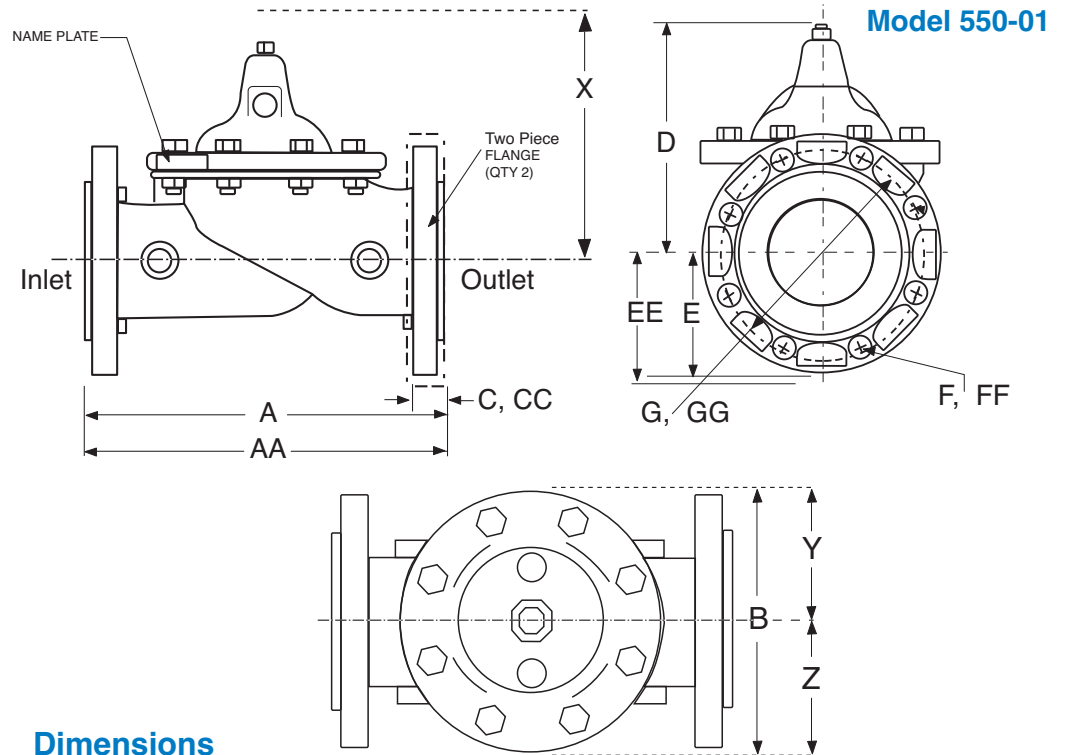

Dimensions

Size (In)	1½	2	2½	3	4	6
(mm)	40	50	65	80	100	150
A 150 ANSI	7.87	9.38	11.00	12.00	15.00	20.00
AA 300 ANSI	7.87	9.38	11.00	12.00	15.00	20.00
B	5.62	6.61	8.00	9.13	11.50	15.75
C	.56	.62	.69	.75	.94	1.00
CC 300 ANSI	.81	.88	1.00	1.12	1.25	1.44
D	5.90	6.25	7.25	8.20	10.21	13.32
E	2.56	3.05	3.54	3.75	4.53	5.61
EE 300 ANSI	3.05	3.25	3.74	4.13	5.02	6.30
F	.62	.75	.75	.75	.75	.88
FF 300 ANSI	.88	.75	.88	.88	.88	.88
G	3.88	4.75	5.50	6.00	7.50	9.50
GG 300 ANSI	4.50	5.00	5.88	6.62	7.88	10.62
Flange Bolts (150 Class)	4	4	4	4	8	8
Flange Bolts (300 Class)	4	8	8	8	8	12
Approx. Ship Wt. Lbs.	25	35	55	75	160	290
Approx. Ship Wt. Kgs.	11.4	16	25	35	73	132

Full Port Functional Data

Size (Inches)	Cv (gpm)*	Cv (l/s)**
1½	32	8
2	54	13
2½	85	20
3	115	27
4	200	48
6	440	105

*Cv = gpm flow at 1 psi drop

**Cv = l/s flow at 1 bar drop



Specifications

Sizes

Globe (inch):
2", 2½", 3", 4", 6", 8", 10", 12"

End Detail

Slip-on Two Piece Flange
Dimensions Per ANSI B16.5

Pressure Rating

ANSI Class 150:
Maximum 285 psi
ANSI Class 300:
Maximum 400 psi

Higher Pressure Available
Please Contact Factory

Operating Temperature

Fluids Compatible with Valve
Materials
-40° to 180° F (-40° to 82° C)

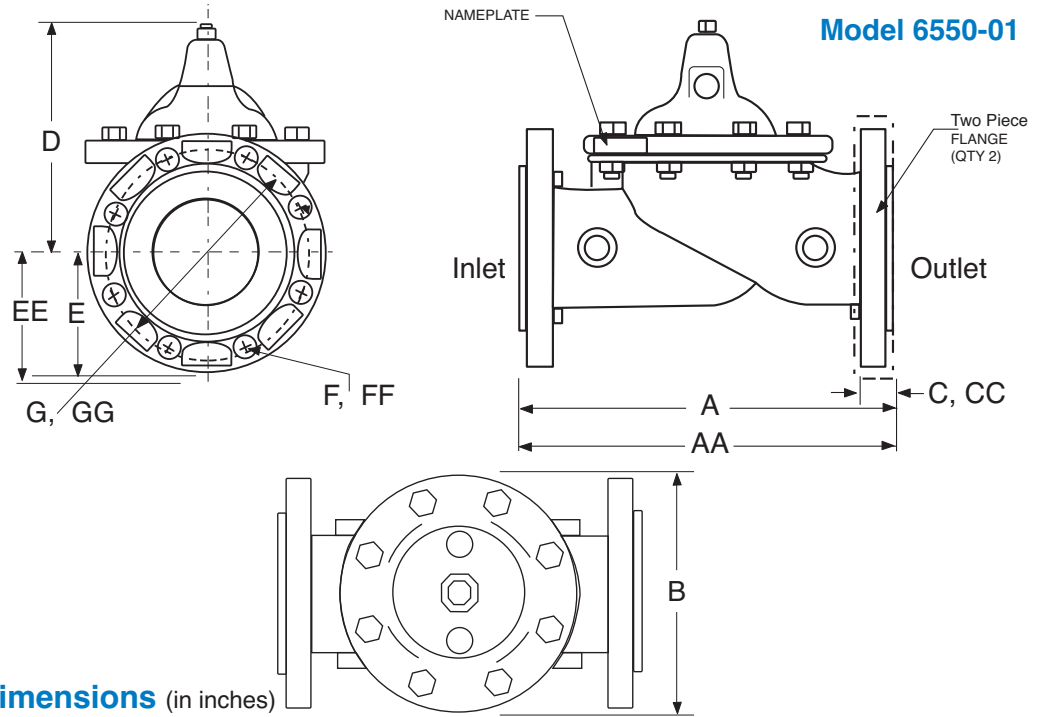

Dimensions (in inches)

Materials

Body, Cover, Trim,
Diaphragm Assembly,
Flanges, and Fasteners
316 Series
Stainless Steel
Electropolished

Disc:
Buna-N® Rubber*

Diaphragm:
Nylon Fabric Reinforced
Synthetic Buna-N® Rubber*

*Contact Factory for Other
Disc or Diaphragm Materials

Size (Inches)	2	2 1/2	3	4	6	8	10	12
Size (mm)	50	65	80	100	150	200	250	300
A 150 ANSI	9.06	11.42	12.20	13.78	18.90	23.62	28.74	33.46
AA 300 ANSI	9.06	11.42	12.20	13.78	18.90	23.62	28.74	33.46
B	5.70	8.06	6.69	9.25	11.61	15.75	20.08	23.62
C	.89	.89	.93	.93	1.02	1.15	1.15	1.25
CC 300 ANSI	.96	.96	1.00	1.00	1.10	1.15	1.46	1.50
D	6.50	7.95	8.20	10.12	13.32	16.39	19.12	20.95
E	3.05	3.54	3.74	4.53	5.61	6.79	7.97	9.55
EE 300 ANSI	3.25	3.75	4.13	5.01	6.30	7.48	8.76	10.24
F	.71	.71	.71	.71	.91	.87	1.02	1.02
FF 300 ANSI	.71	.75	.87	.87	.87	1.03	1.16	1.34
G	4.75	5.50	6.00	7.50	9.50	11.75	14.25	17.00
GG 300 ANSI	5.00	5.88	6.62	7.88	10.62	13.00	15.25	17.72
Flange Bolts (150 Class)	4	4	4	8	8	8	12	12
Flange Bolts (300 Class)	8	8	8	8	12	12	16	16
Approx. Ship Wt. Lbs.	25	40	40	75	160	290	419	728
Approx. Ship Wt. Kgs.	11.4	19	19	35	73	132	190	330
X Pilot System	13.00	14.00	15.00	17.00	29.00	31.00	33.00	36.00
Y Pilot System	9.00	10.00	11.00	12.00	20.00	22.00	24.00	26.00
Z Pilot System	9.00	10.00	11.00	12.00	20.00	22.00	24.00	26.00

100-44 Reduced Port Functional Data

Size (Inches)	Cv (gpm)*	Cv (l/s)**
2	38	9
2½	50	12
3	67	16
4	138	33
6	242	58
8	555	133
10	923	222
12	1492	359

*Cv = gpm flow at 1 psi drop

**Cv = l/s flow at 1 bar drop

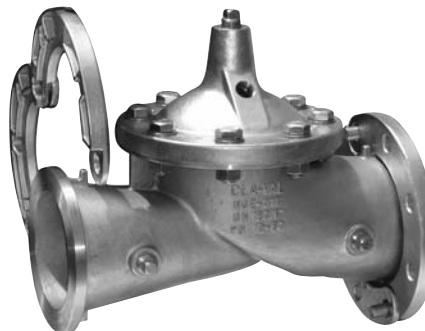

When Ordering Please Specify:

1. Catalog No. 100-44
2. Valve Size
3. Fluid Being Handled
4. Fluid Temperature
5. Inlet Pressure Range
6. Outlet Pressure Range
7. Maximum and Minimum Differential Pressure
8. Flow Rate Range

550-01 Valve Selection	100-46 Pattern: Globe (G), Angle (A), End Connections: Threaded (T), Grooved (GR), Flanged (F) Indicate Available Sizes						
	Inches	1½	2	2½	3	4	6
	mm	40	50	65	80	100	150
Basic Valve 100-46	Pattern	G	G	G	G	G	G
	End Detail	F	F	F	F	F	F
Suggested Flow (gpm)	Maximum	125	210	300	460	800	1800
	Maximum Surge	280	470	670	1000	1800	4000
Suggested Flow (Liters/Sec)	Maximum	8	13	19	29	50	113
	Maximum Surge	10.1	30	42	63	113	252

100-46 Series is the full internal port Hytrol.

6550-01 Valve Selection	100-44 Pattern: Globe (G), Angle (A), End Connections: Flanged (F) Indicate Available Sizes								
	Inches	2	2½	3	4	6	8	10	12
	mm	50	65	80	100	150	200	250	300
Basic Valve 100-44	Pattern	G	G	G	G	G	G	G	G
	End Detail	F	F	F	F	F	F	F	F
Suggested Flow (gpm)	Maximum	200	300	460	580	1025	2300	4100	6400
	Maximum Surge	420	600	900	990	4000	3970	7050	11000
Suggested Flow (Liters/Sec)	Maximum	12.5	18	32	37	113	145	258	403
	Maximum Surge	26	38	55	62	111	250	444	693

100-44 Series is the reduced internal port size version of the 100-01 Series.

Pilot System Specifications

Adjustment Ranges

0 to 75 psi Max.
20 to 200 psi *
100 to 300 psi

*Supplied unless otherwise specified
Other ranges available, please consult factory

Temperature Range

Water: to 180°F

Materials

Standard Pilot System Materials

Pilot Control: Stainless Steel Type 303
Trim: Stainless Steel Type 303
Rubber: Buna-N® Synthetic Rubber

Optional Pilot System Materials

Pilot Systems are available with optional
316 Stainless Steel or Monel materials.

Note: Available with remote sensing control.

When ordering Please Specify:

1. Catalog No. 550-01/6550-01
2. Valve Size
3. Pilot System Materials
4. End Detail (150/300)
5. Fluid to be Handled
6. Fluid Temperature
7. Inlet Pressure
8. Outlet Pressure
9. Adjustment Range
10. Desired Options



E-550-01/6550-01 (R-8/2011)

CLA-VAL

PO Box 1325 Newport Beach CA 92659-0325
Phone: 949-722-4800 • Fax: 949-548-5441

CLA-VAL CANADA

4687 Christie Drive
Beamsville, Ontario
Canada L0R 1B4
Phone: 905-563-4963
Fax: 905-563-4040

CLA-VAL EUROPE

Chemin des Mesanges 1
CH-1032 Romanel/
Lausanne, Switzerland
Phone: 41-21-643-15-55
Fax: 41-21-643-15-50

©COPYRIGHT CLA-VAL 2011 Printed in USA
Specifications subject to change without notice.

www.cla-val.com

Represented By: