

Float Control For Open Tanks



- **Accurate Liquid Level Control**
- **Fully Hydraulic Operation**
- **Simple Design, Easy Maintenance**
- **No Lubrication Necessary**
- **No Gears, No Mechanical Linkage Between Valve and Control**

The Cla-Val Model CF1-C1 Float Control is a float-actuated, multi-port pilot control which provides non-modulating, two-position, on-off operation. It is used primarily to operate remotely located Cla-Val valves requiring three-way or four-way pilot valve operation. Designed for use in open tanks, this control operates on a minimum level change of approximately one inch. Maximum level change is nineteen inches. This level adjustment can be located up to 11½ feet from the control by adding float rod extensions.

The float moves freely on the float rod. On rising liquid level, the float contacts the upper stop and lifts the float linkage to the "UP" position. As the liquid level lowers, the control stays in the "UP" position until the float contacts the lower stop. The control then shifts to the "DOWN" position.

Specifications

Piping Connections	1/8" NPT
Pressure Rating	150 psi max.
Temperature Rating	Water: to 150°F.
Materials	In contact with operating fluid: Nylon Reinforced Delrin®, Stainless Steel, Monel, with Buna-N® Seals Float linkage and float rod: Brass and PVC Base plate: 316 Stainless Steel Float: 304 Stainless steel float Other materials available: Stainless steel rod and stops Brass rods Brass base plate
Float	5 3/8" diameter. If maximum temperature exceeds 160°F. specify a stainless steel rods. Available at extra cost.
Float Rod	Standard: Two 12" sections of PVC rod, with 12" extension increments at extra cost. Larger counterweight required if float rod length exceeds 5'. Optional: 24" stainless steel rod, with 24" extension increments at extra cost. Larger counterweight required if float rod length exceeds 2 feet.
Level Differential	1" min to 18" max. with PVC rod 1" min to 40" max. with stainless steel rod
Operating Fluids	Clean liquids or gases compatible with specified materials.
Shipping Weight	12 lbs.

Dimensions (In Inches)

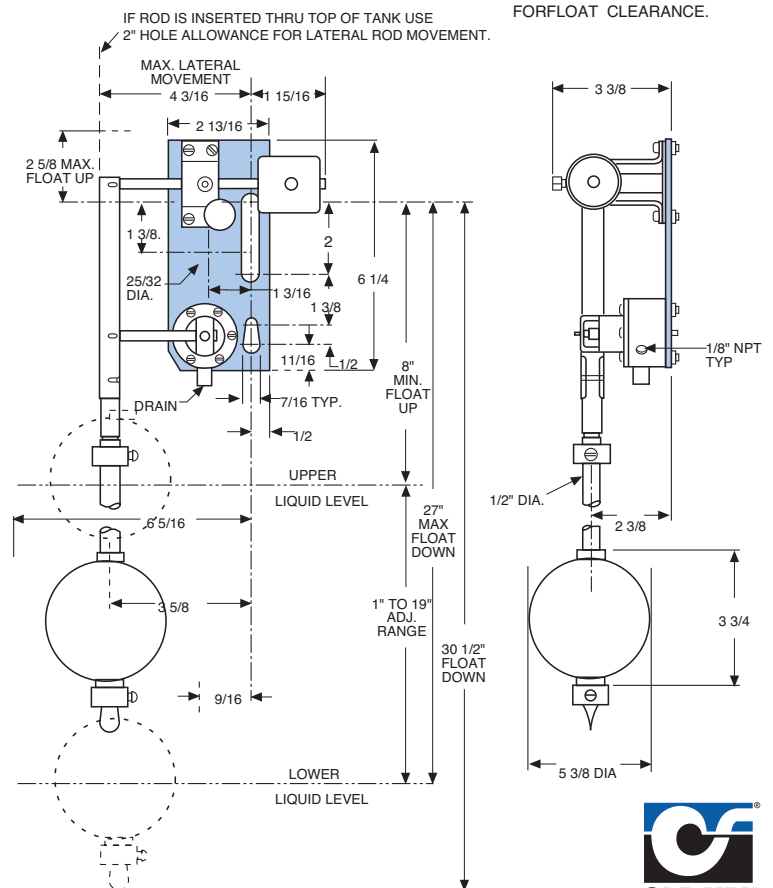

MOUNT BRACKET A MINIMUM OF 1-1/2" FROM TANK WALL FOR FLOAT CLEARANCE.

Installation Data

The float control is mounted above the high water level in the tank. The valve is installed in the line leading to the tank and is connected to the float control pilot by tubing. (Min. 3/8" tubing)

When line pressure is used to operate the valve, tubing connections are made from the float control pilot to the valve cover, and also to the inlet side of the valve. An X46 Flow Clean Strainer must be installed in the inlet side of the valve. The control may be installed at any elevation above the valve, providing that the flowing line pressure in psi

is equal to, or greater than, the vertical distance in feet between the valve and the float control.

An independent source of air or water may be used to operate the valve. The pressure from this independent source must constantly be equal to or greater than pressure at the valve inlet. The independent source is connected to the float control pilot in place of the supply line connected to the inlet side of the valve. If the Model 100-01 under the control of the CF1-C1 is 8" or larger, auxiliary Hytrol valves may be required. Consult factory for details.

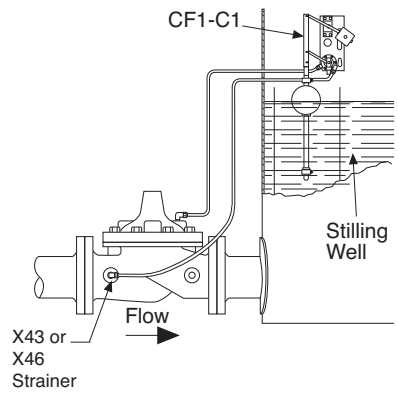

Note: We recommend protecting Float Control tubing and valve from freezing temperatures.

For Controlling Hytrol Valve

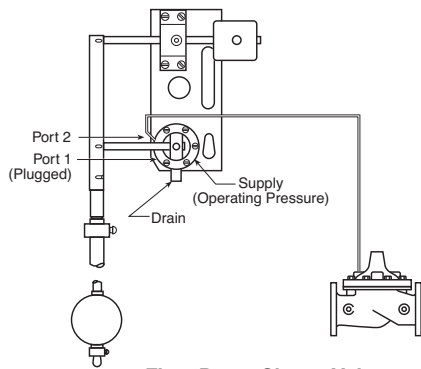

Float Down Closes Valve

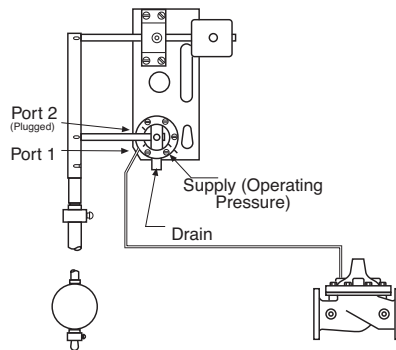

Float Up Closes Valve

NOTE:

A stilling well (Min. 8" I.D.) must be provided around the float if the liquid surface is subject to turbulence, ripples or wind.

When Ordering, Please Specify

1. Catalog No. CF1-C1
2. Size and type of Valve to be controlled.
3. Material if different from standard
4. Float rod length if longer than 2 ft.

For Controlling Powertrol Valves

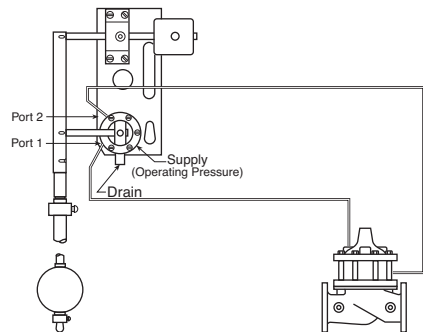

Float Up Closes Valve

Float Up Opens Valve

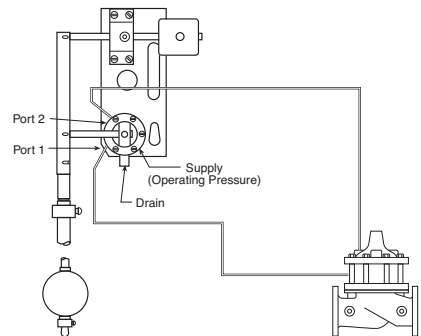

For Controlling Two Valves Simultaneously

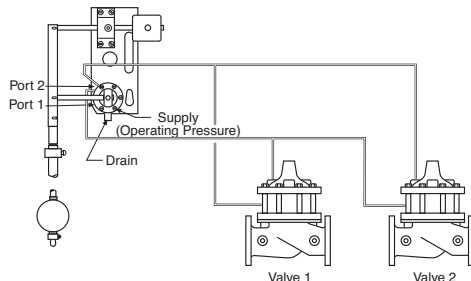

Operation

Float Position	Valve 1	Valve 2
UP	CLOSED	OPEN
DOWN	OPEN	CLOSED

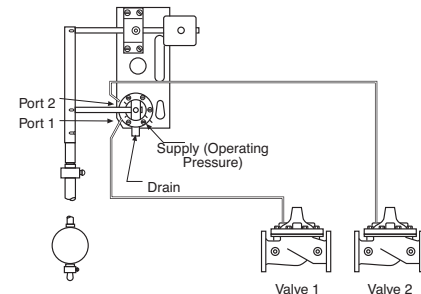

E-CF1-C1 (R-7/2011)

CLA-VAL

PO Box 1325 Newport Beach CA 92659-0325
Phone: 949-722-4800 • Fax: 949-548-5441

CLA-VAL CANADA
4687 Christie Drive
Beamsville, Ontario
Canada L0R 1B4
Phone: 905-563-4963
Fax: 905-563-4040

CLA-VAL EUROPE
Chemin des Mesanges 1
CH-1032 Romanel/
Lausanne, Switzerland
Phone: 41-21-643-15-55
Fax: 41-21-643-15-50

©COPYRIGHT CLA-VAL 2011 Printed in USA
Specifications subject to change without notice.

www.cla-val.com

Represented By: