



MODEL **124-02**
624-02

Float Valve

INTRODUCTION

The Cla-Val 124-02/624-02 is an automatic valve designed to open wide when liquid level reaches a predetermined low point and to shut drip tight when a predetermined high point is reached. It is a hydraulically operated, pilot controlled, diaphragm type globe or angle valve. The Float Valve is actuated by a float ball to limit the high and low liquid levels in the tank or reservoir by closing or opening the main valve. High and low liquid levels are adjustable. The float control can be remotely located only if the flowing line pressure at the valve inlet (in psi) is equal to or greater than the elevation (in feet) from the main valve to the float pilot control.

INSTALLATION

1. Allow sufficient room around the valve assembly to make adjustments and maintenance.

NOTE: before the valve is installed, the pipeline should be flushed of all chips, scale and foreign matter.

2. It is recommended that a gate or line block valves be installed upstream of the 124-02/624-02 valve assembly to facilitate isolating the valve for preventive maintenance. If the discharge from the Float Valve is to atmosphere, an outlet shutoff valve may not be required.

3. Place the valve assembly in the line with flow through the valve in the direction of flow arrows or by the inlet nameplate. Check all fittings and hardware for proper makeup and that no apparent damage is evident.

4. Cla-Val Valves operate with maximum efficiency when mounted in horizontal piping with the cover UP; however, other positions are acceptable. Due to size and weight of cover and internal components of six inch valves and larger, installation with the cover up is advisable. This makes periodic inspection of internal parts readily accessible.

5. Caution must be taken in the installation of this valve to insure that galvanic and/or electrolytic action does not take place. The proper use of dielectric fittings and gaskets are required in all systems using dissimilar metals.

6. When the valve is installed over water in the tank or reservoir mount the valve to position the float rod and ball assembly (item 3 CF1-C1) **vertically down** from the valve.

7. If the surface of the water in the tank is subject to waves by wind or by valve discharge, **a stilling well must be installed around the float ball assembly.** 8" I.D. PVC pipe is suggested.

8. **INITIAL ADJUSTMENT.** See CF1-C1 on reverse side for proper assembly of the float rod, ball and stop collars and threading into the Link Assembly. Temporarily remove float. Adjust counterweight on the rod to balance the weight of the link assembly and float rod assembly, less the float. Replace float.

9. Move float rod to the "up" position. Adjust the upper stop collar on the float rod assembly approximately three inches above the high water level desired in the tank. Move float rod to "down" position. Adjust the lower stop collar on the float rod assembly approximately three inches below the desired low water level. Tighten stop collar screws on the CF1-C1.

OPERATION AND START-UP

1. Prior to pressurizing the valve assembly make sure the necessary gauges to measure pressure in the system are installed as required by the system engineer. A Cla-Val X101 Valve Position Indicator may be installed in the center cover port to provide visual indication of the valve stem position during start-up.

CAUTION: During start-up and test procedures a large volume of water may be discharged downstream. Check that the downstream venting is adequate to prevent damage to personnel and equipment.

If the main valve closes too fast it may cause surging in upstream piping.

2. If isolation valves (B) are installed in the pilot system, open these valves (see 124-02 schematic).

3. Slowly open the upstream block valve.

4. While the tank is filling, the float rod and link assembly (CF1-C1 item 19) can be moved slowly to the up position to manually close the main valve. This operation tests the closure of the Float Valve and also will purge air from the control lines and cover chamber. Carefully loosen tube fittings at highest points and bleed air from system. Carefully loosen the plug at top of main valve cover. If an indicator is installed, carefully loosen the vent at top of indicator. Bleed air from cover and tighten plug. Tighten tube fittings.

MAINTENANCE

1. Cla-Val Valves and Controls require no lubrication or packing and a minimum of maintenance. However, a periodic inspection schedule should be established to determine how the fluid handled is affecting the efficiency of the valve assembly. Minimum of once per year.

2. Repair and maintenance procedures of the Cla-Val Hytrol Main Valve and the control components are included in a more detailed IOM manual. It can be downloaded from our web site (www.cla-val.com) or obtained by contacting a Cla-Val Regional Sales Office.

3. **When ordering parts always refer to the catalog number and stock number on the valve nameplate.**

SYMPTOM	PROBABLE CAUSE	REMEDY
Continuous drain from control discharge port	Damaged auxiliary valve diaphragm (3B)	Replace diaphragm
	Loose diaphragm assembly auxiliary valve (3B)	Tighten assembly
	Damaged control (2)	Replace control (pilot)
Continuous flow from control discharge	Damaged control (2)	Replace control (pilot)
	Damaged auxiliary valve diaphragm (3A)	Replace diaphragm
	Loose diaphragm assembly auxiliary valve (3A)	Tighten assembly
Main valve fails to close	Lack of pressure at valve inlet (install gauge at valve inlet to check for this problem) Note if pressure at valve inlet is above 5 psi	Increase inlet pressure to 5 psi (minimum requirement under flowing conditions)
	isolation valve in control tubing closed	Open CK2 isolation valve
	Float and float rod fails to move with liquid level change (stays in down position)	Free float mechanism
Main valve fails to open	Inlet gate or block valve closed.	Open isolation valve
	Float and float rod fails to move with liquid level change (stays in up position)	Free float mechanism

124-02/624-02 SCHEMATIC

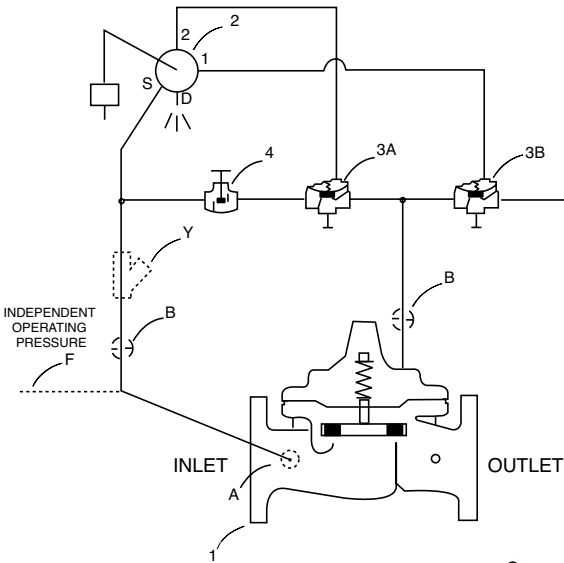

BASIC COMPONENTS

- 1 100-01 Hytrol (Main Valve)
100-20 600 Series Hytrol (Main Valve)
- 2 CF1-C1 Float Control
- 3 100-01 Hytrol (Reverse Flow)
- 4 CGB Globe Valve

OPTIONAL FEATURES

- A X46A Flow Clean Strainer
- B CK2 (Isolation Valves)
- F Independent Operating Pressure
- S CGB Globe Valve
- Y X43 "Y" Strainer

HYTROL MAIN VALVE

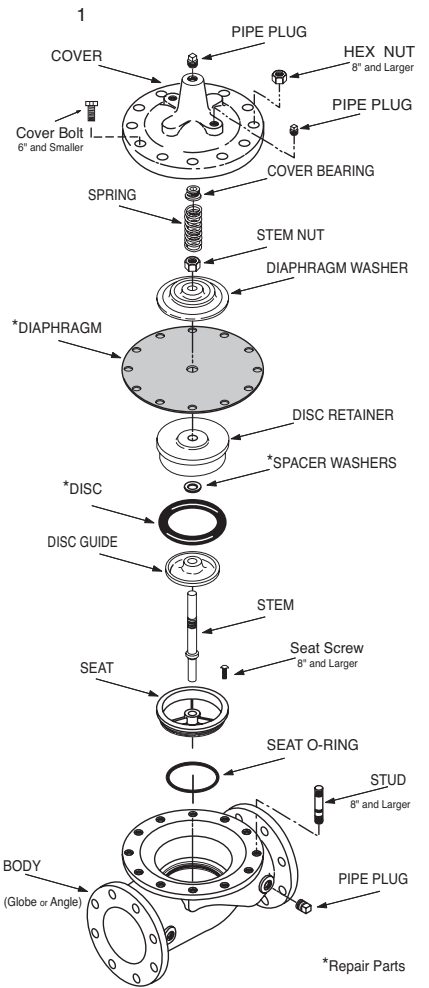

*Repair Parts

ITEM	DESCRIPTION
1	Link Assembly
2	Cotter Pins (2 req'd)
3	Float Rod Assembly (2 ft.)
FLOAT ROD ASSY. BREAKDOWN	
4	Upper Float Rod (1 ft.)
	Upper Float Rod (2 ft.)
5	Stud (Req. for connecting upper and lower rods and one for each extension rod)
6	Extension Float Rod (1 ft.)
	Extension Float Rod (2 ft.)
7	Stop Collar (2 req'd)
8	Set Screw (1 ea. stop collar)
9	Lower Float Rod (1 ft.)
	Lower Float Rod (2 ft.)
10	Float Ball
11	Base and Mounting Plate
12	Pilot Valve Assembly CF1-C1
13	Machine Screw 6/32 x 1 1/2" (6 req'd.)
14	Hex Nut 6/32 (6 req)
15	Counter Balance Bracket Assy.
16	Machine Screw 10/32 x 9/16" (4 req'd.)
17	Hex Nut 10/32 (4 req'd.)
18	Counterweight (varies with rod length, includes set screws)
19	Pilot & Bracket Assembly CF1-C1
COUNTERWEIGHT NOT INCLUDED	

CF1-C1

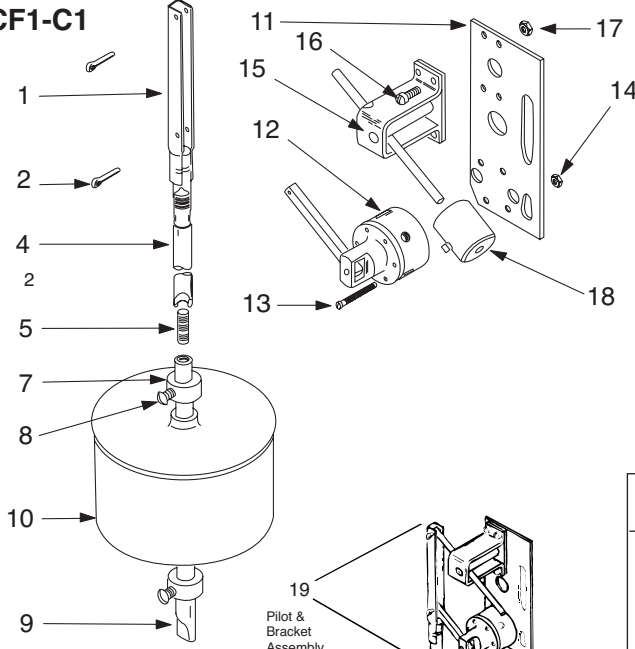

X46A A



CK2 B



CGB 4,S



X43 Y



NOTE:

A stilling well (Min. 8" I.D.) must be provided around the float if the liquid surface is subject to turbulence, ripples or wind.

For a more detailed IOM Manual go to www.cla-val.com or contact a Cla-Val Regional Sales Office.