



— SERIES — **580 & 581**

WAFER & GLOBE SILENT CHECK VALVES

OPERATION:

Cla-Val Silent Check Valves operate automatically, to open... when pump flow starts and close silently ...when pump flow stops.

INSTALLATION:

Silent Check Valves, Wafer and Globe style must be installed between flat faced iron or steel flanges per ANSI B16.5 or Awwa 207, utilizing a full faced gasket to bridge the joint between the seat O.D. (2) and the body (1) flange face. In this manner a pressure seal at this joint is made (see **Note 1**). Install the valve so that the nameplate data is plainly read and the flow arrow points in the flow direction.

MAXIMUM ALLOWABLE INSIDE DIAMETER OF FLANGE (SEE NOTE NO. 1)			
VALVE SIZE	A	VALVE SIZE	A
2 1/2	2.940	14	14.140
3	3.570	16	16.160
4	4.570	18	18.180
5	5.660	20	20.200
6	6.720	24	24.250
8	8.720	30	30.250
10	10.880	36	36.250
12	12.880	42	42.250

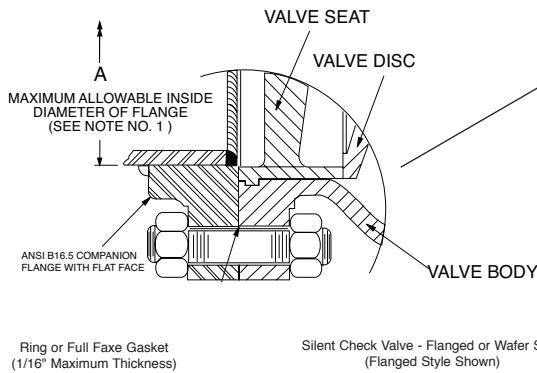

Note No. 1 - The mating companion flange I.D. must overlap the Valve seat. This is required to achieve a seal between the seat O.D. and The Body I.D. Interface area.

Series 581
Globe Style
Check Valve
2" thru 42"

Note 1: flanged gasket must bridge this joint for pressure seal

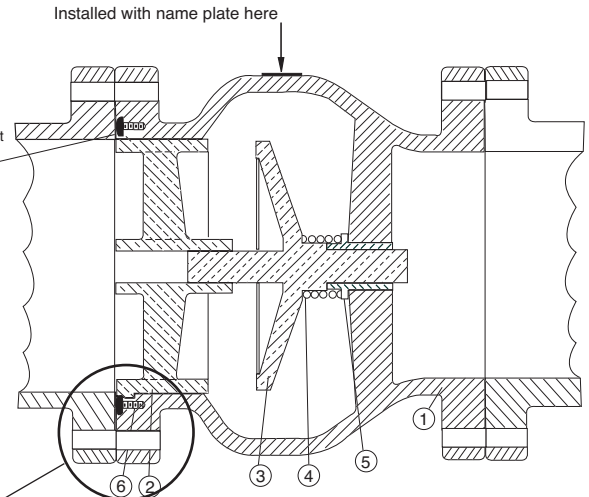

Detail	Description	Material
1	Body	Cast Iron
2	Seat*	Bronze or SS
3	Disc*	Bronze or SS (Optional Buna-N®)
4	Spring*	Stainless Steel
5	Bushing*	Bronze
6	Screw*	Stainless Steel (3" & larger valves)

Note 2: All size 2" and 2 1/2" valves have threaded seats in lieu of screws

* Recommended Spare Part Kit

STANDARD RING GASKET DIMENSIONS (SEE NOTE NO. 2)							
Valve Size	I.D. For 125 Lb. and 250 Lb. Gasket	O.D. for 125 Lb. Gasket	O.D. for 250 Lb. Gasket	Valve Size	I.D. For 125 Lb. and 250 Lb. Gasket	O.D. for 125 Lb. Gasket	O.D. for 250 Lb. Gasket
2 1/2	2.875	4.875	5.125	14	14.000	17.750	19.125
3	3.50	5.375	5.875	16	16.000	20.250	21.250
4	4.50	6.875	7.125	18	18.00	21.625	23.500
5	5.562	7.750	8.500	20	20.00	23.875	25.750
6	6.625	8.75	9.875	24	24.000	28.250	30.500
8	8.625	11.000	12.125	30	30.000	34.750	37.500
10	10.750	13.375	14.250	36	36.000	41.250	44.000
12	12.750	16.125	16.625	42	42.000	48.000	50.750

MAINTENANCE:

Cla-Val Silent Check Valves are ruggedly designed for years of trouble-free service. Therefore, regular maintenance is not required. However, during initial start-up period the following problems may surface (due to mis-application) that can be easily resolved:

A. No Flow thru Valve:

1. Observe that the flow arrow name plate, on the valve body, is pointing in the direction of flow.
2. Check that the down stream shut-off valve is full open.

B. Valve Chatters:

1. Confirm that the flow velocity is a minimum 3'/Sec.
2. Check that there is a minimum of 3 diameters of straight pipe installed up stream of the silent check valve.

C. Valve Leakage:

1. Confirm a full face gasket is installed per Note 1.

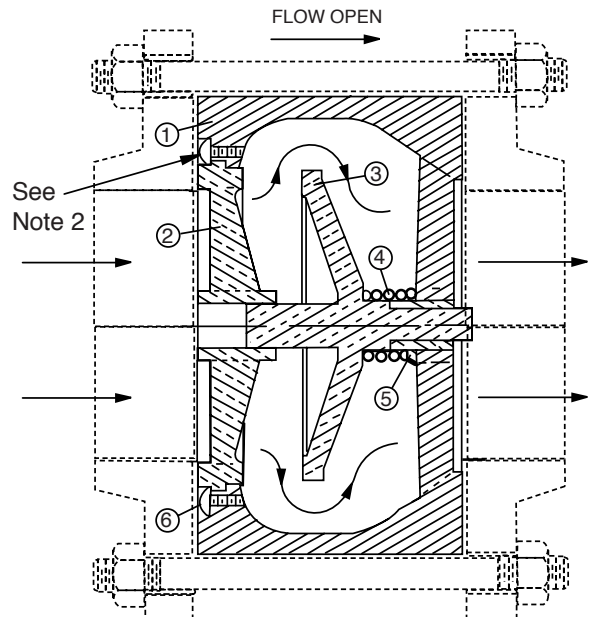

SERIES 580
WAFER STYLE CHECK VALVE

2" THRU 10"

TO REMOVE VALVE FROM PIPELINE FOR INSPECTION:

1. Shut off pump and pressure upstream and shut off isolation valve downstream to completely isolate check valve. A skilled pipe fitter should be used for this work.
2. Lay valve to rest on its downstream side and remove cap screws as shown in Fig. 3. **Note** that 2" and 2-1/2" valves threaded seats in lieu of cap screws.
3. Grip seat spokes by hand to pull out seats or push down the disc and release quickly to allow force of the spring to pop out the seat.
4. With seat removed, check that all internal parts are freely removable from valve body.
5. Examine all parts for wear/damage and order replacement PARTS KITS as shown below.

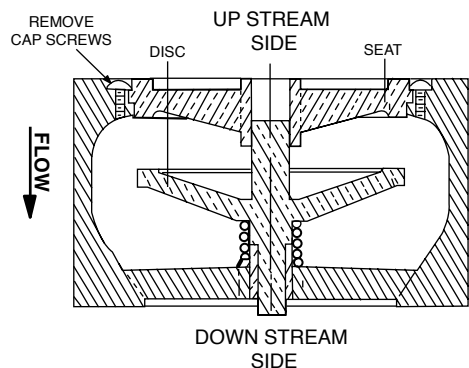
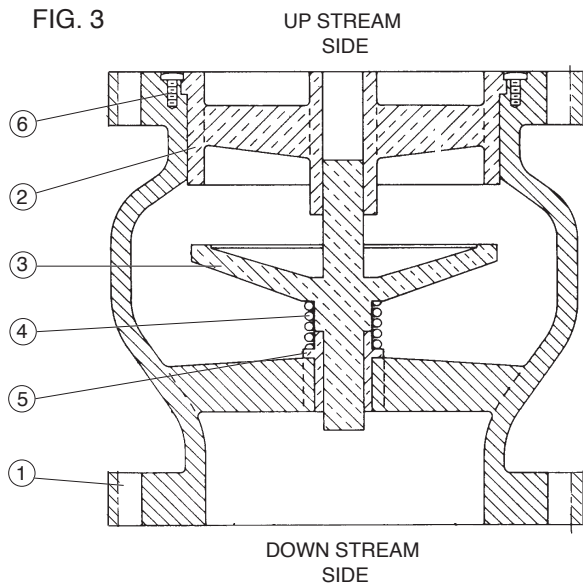

FIG. 3



Silent Check Valve Buna-N® Seating Detail (Optional)

PROVIDES DROP-TIGHT SEATING
AT LOW PRESSURES WITHOUT DAMAGE TO
BUNA-N® SEAL AT HIGHER PRESSURE

The unique seating action begins with the initial contact between the metal valve disc and the Buna-N® Seal. As pressure increases, Buna-N® seal is slightly compressed and allows the disc to make contact with the metal portion of the valve seat. This metal-to-metal contact prevents any further compression of the Buna-N® seal. (Over compression of the synthetic seal can lead to its destruction and cause potential leakage.)

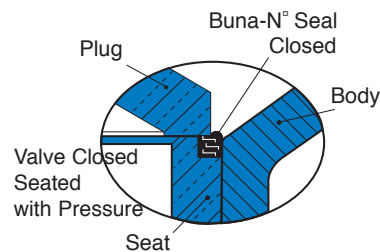
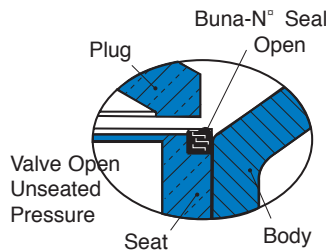

Detail	Description	Material
1	Body	Cast Iron
2	Seat*	Bronze or SS
3	Plug*	Bronze or SS (Optional Buna-N®)
4	Spring*	Stainless Steel
5	Bushing*	Bronze
6	Screw*	Stainless Steel (3" & larger valves)

Note 2: All size 2" and 2 1/2" valves have threaded seats in lieu of screws

* Recommended Spare Part Kit

Silent Check Valve Spare Part Kits

Series 580 Wafer Style		
Model	Size	Kits
580	2"	A B C D
580	2 1/2"	A B C D
580	3"	A B C D
580	4"	A B C D
580	5"	A B C D
580	6"	A B C D
580	8"	A B C D
580	10"	A B C D

Series 581 Globe Style		
Model	Size	Kits
581	2"	A B C D
581	2 1/2"	A B C D
581	3"	A B C D
581	4"	A B C D
581	5"	A B C D
581	6"	A B C D
581	8"	A B C D
581	10"	A B C D
581	12"	A B C D
581	14"	A B C D

A- Kit Includes Detail 2 Bronze Seat & Detail 3 Disc
 B- Kit Includes Detail 2 Stainless Steel Seat & Detail 3 Disc
 C- Kit Includes Detail 2 Stainless Steel Seat, Detail 3 Disc, Detail 4 Spring, & Detail 5 Bronze Bushing
 D- Kit Includes Detail 2 Stainless Steel Seat, Detail 3 Disc, Detail 4 Spring, & Detail 5 Stainless Steel Bushing