

— MODEL — **X117D**

Valve Position Transmitter

DESCRIPTION

The Cla-Val Model X117D Valve Position Transmitter is designed to provide analog signal (4 - 20 mA, 2 wire) output of valve position for Cla-Val Main Valves. A stem extension is fitted to the main valve stem with the position transmitter mechanically linked to it. The valve stem is mechanically linked to the electronics for an output signal that is in direct proportion to valve position. Provisions are made for bleeding air from valve cover through a small bleed screw and washer located on adapter.

INSTALLATION

Normally, the X117D is supplied mounted on the Cla-Val main valve. If X117D has not been installed at factory, then install stem, adapter, mounting bracket with transmitter (in that order) as shown on drawing No. 200000.

OPERATION

The signal from the position sensing linkage mechanism is converted to a two-wire 4 to 20 mA current output appearing at the output terminals. The excitation voltage ranges from 12 to 35 Volts DC. The minimum supply voltage is a function of total loop resistance. It may be calculated using the formula:

$$V(\text{min}) = (0.02 \times \text{Load Resistance}) + 12 \text{ VDC}$$

WIRING

Loosen jam nut holding transmitter and bracket to adapter when connecting transmitter to field wiring. Tighten jam nut after connections and adjustments are made.

Use good field wiring practices for low voltage DC analog instrumentation wiring (suggest minimum of 18-gauge multistrand wire). Avoid potential ground loops. Calibration of transmitter should be done with a temporary hookup of test equipment before final wiring connections are made.

Units with NEMA 6, IP-68 enclosures have permanently attached 8' shielded cable leads. Use Red wire for positive and Black wire for negative.

Units before Feb. 2000 have NEMA 6 enclosure with MS3102E-14S-6PAmphenol plug and socket for attaching leads. Use "A" contact for positive and "B" contact for negative.

For best noise immunity, use twisted pair shielded cable to connect field wiring to the transmitter. The shield of the cable should be open at the transducer and grounded at the other end. Units with permanently attached cable are supplied with shield open inside transmitter.

CALIBRATION

1. When properly adjusted, the transmitter will have the valve closed position within 0% to 30% of total transmitter range and the valve open position within 80% to 100% of total transmitter range. At valve closed position the transmitter will have a 4 mA output and at fully open position the transmitter will have a 20 mA output.

IMPORTANT CAUTION: The transmitter wire rope mechanism is spring loaded to retract and can be damaged by a sudden release



of the wire rope. Use care to insure that it is returned to the transmitter very slowly during start up and operation. This damage may not be covered by warranty.

2. You will need the following tools to calibrate and align the X117D:
 - A.) A small flat blade screwdriver (.105 Max. width x .023" max. thickness) with non-metallic handle to fit the span and null potentiometer
 - B.) A 4-20 mA calibration/tester or multiamp-tester/meter or some means of measuring the 4-20 mA transmitter output
 - C.) Hand tools to adjust and tighten X117D assembly during calibration

3. Preliminary mechanical settings. (Refer to Drawing No. 200000) Be sure that the valve is in the fully **closed** position. See Technical Manual for the main valve for information on this. Check that line isolation or block valves are closed.

Adjust Nut Coupler (9) up or down on stem until gap between wire rope end and transmitter housing is according to table (below). The Hex Coupler (10) is used to tighten nut coupler to stem. A minimum gap is required, see Reference Table. (Refer to Drawing No. 200000)

Long threaded end of Hex Coupler (10) has two hex nuts (11) for adjusting position of end of wire rope directly over the opening in the top of the transmitter. Use one hex nut on each side of the wire rope end. Wire rope should go vertically up and down without noticeable angle from vertical.

4. Temporarily connect calibration equipment (milliamp meter and power supply or portable instrumentation tester) to transmitter wiring. Calculate total loop resistance to determine minimum load resistor. See OPERATION section. Remove two calibration cover screws found on housing end.

Refer to calibration equipment and adjust transmitter potentiometer marked "NULL" until the meter reads 4 mA. A clockwise turn increases output. Use care in adjusting the potentiometer while turning the screwdriver.

Refer to calibration equipment (see Step 4) and adjust potentiometer marked "SPAN" until the meter reads 20 mA. A clockwise turn increases output. Use care in adjusting the potentiometer while turning the screwdriver.

5. For the most accurate calibration it is necessary to open valve fully. CAUTION: This will either allow a high flow rate through the valve, or the downstream pressure will quickly increase to the inlet pressure. In some cases, this can be very harmful. Where this is the case, and there are no block valves in the system to protect the downstream piping, it should be realized that steps should be taken to remedy this situation before proceeding further. Normally, block valves are to be used to protect downstream piping while the valve is in the open position. Close downstream block valve. Vent cover chamber to atmosphere. Slightly open inlet block valve. Allow valve to open while fluid is vented from cover chamber. When flow stops valve is in the fully open position. Note: continuous leakage from cover chamber could mean additional troubleshooting of the main valve or pilot system must be done.

7. There is some interplay between:

- 1.) the "span" and "null" settings,
- 2.) the 4 to 20 mA signal and,
- 3.) the actual valve open and closed positions.

Repeat steps 4-6 above. Cycle valve from open to closed positions and check settings as necessary to achieve desired valve position signal accuracy.

6. With valve in fully open position, inspect position of wire rope and nut coupler. (See Step 3). Adjust if necessary.

8. Remove all calibration equipment and attach permanent wiring. Recheck wiring and output signals at remote location. See **Wiring** section. Reinstall two cover screws on housing. Recheck and tighten all fasteners. Bleed air from main valve cover through small bleed screw and washer located on one wrench flat of adapter.

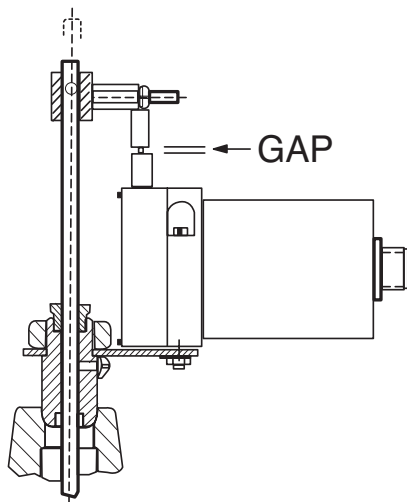

Coupler gap is set with valve in fully closed position. This establishes the minimum mechanical position for 4 mA output.

ADJUSTMENT: Zero and span adjustments allow setting the 4 mA position (valve closed) within 0% to 30% of total transmitter range and setting the 20 mA position (valve fully open) within 80% to 100% of total transmitter range.

MAINTENANCE

The X117D is constructed of durable materials which normally requiring no lubrication or periodic maintenance. The two 'O' rings (2) (p/n 00951E) in the adapter (5) that seal against the stainless steel actuating stem (1) will need replacement if signs of leakage at the stem occur.

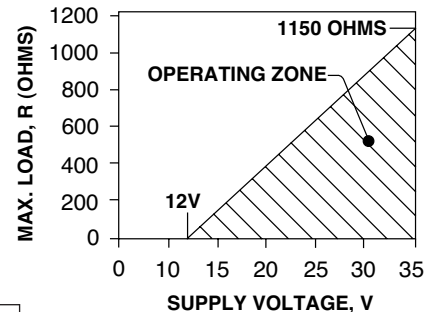
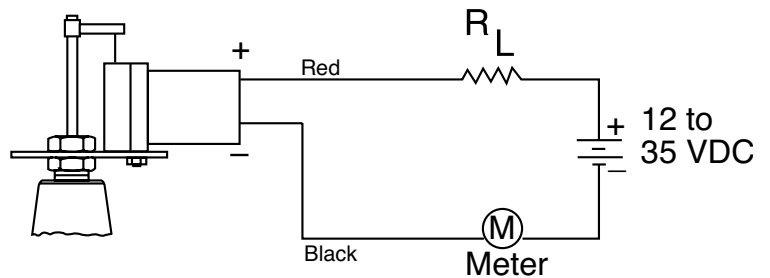

X117D Part Number	Valve Size (inch)		Valve Stem Travel (inch)	"GAP"		Transmitter Total Range
	100-01	100-20		Coupler Setting GAP (inch)	Minimum	
20000019F	1 1/4		0.400	3/16"	1"	
20000019F	1 1/2		0.490	3/16"	1"	
20000020A	2	3	0.590	1/8"	1"	
20000020A	2 1/2		0.714	1/16"	1"	
20000021A	3		0.835	1/16"	1"	
20000001A	4	6	1.109	9/16"	2"	
20000002A	6	8	1.584	3/16"	2"	
20000003A	8	10	2.242	7/16"	3"	
20000004A	10	12	2.711	1/8"	3"	
20000005A	12	16	3.343	5/16"	4"	
20000006A	14	N/A	3.920	9/16"	5"	
20000007K	16	20 & 24	4.584	3/16"	5"	
20000008J	24	N/A	6.504	2 1/4"	10"	