

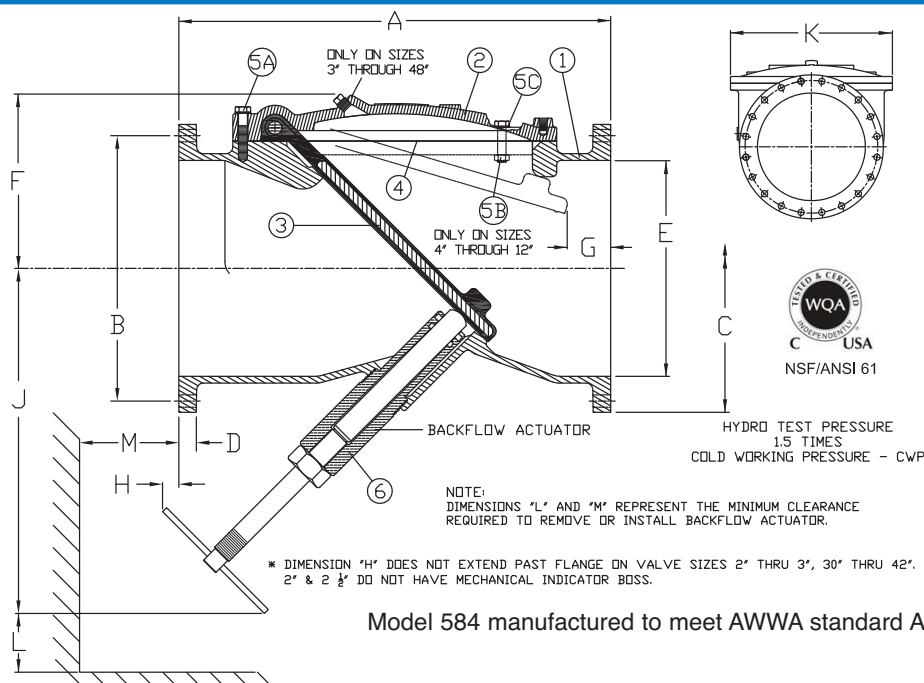

Model 584

Flex-Check Valve™



ANSI Class 150 Flat Face Flange

| Valve Size | A | B | C | D | E | F | G | H* | J | K | L | M | Bolt Size | No. of Bolts | Wt. Lbs. |
|------------|--------|--------|--------|---------|-------|----------|--------|----------|----------|---------|-------|-------|-----------|--------------|----------|
| 2 | 8 | 4 3/4 | 6 | 5/8 | 2 | 3 3/8 | 1 5/8 | -1/2 | 6 3/4 | 5 9/50 | 1 1/2 | 1 1/2 | 5/8 | 4 | 27 |
| 2 1/2 | 8 1/2 | 5 1/2 | 7 | 11/16 | 2 1/2 | 3 3/8 | 1 5/8 | -1/2 | 7 | 5 9/50 | 1 1/2 | 1 1/2 | 5/8 | 4 | 32 |
| 3 | 9 1/2 | 6 | 7 1/2 | 3/4 | 3 | 5 3/25 | 1 5/8 | -3/8 | 7 1/2 | 7 1/2 | 1 1/2 | 1 1/2 | 5/8 | 4 | 45 |
| 4 | 11 1/2 | 7 1/2 | 9 | 3/4 | 4 | 5 3/4 | 2 1/8 | 3 3/8 | 10 3/4 | 8 1/4 | 2 1/2 | 2 1/2 | 5/8 | 8 | 70 |
| 6 | 15 | 9 1/2 | 11 | 3/4 | 6 | 6 7/8 | 2 1/8 | 1 3/8 | 11 3/8 | 11 3/25 | 3 | 3 | 3/4 | 8 | 130 |
| 6 | 14 | 9 1/2 | 11 | 3/4 | 6 | 6 7/8 | 2 1/8 | 1 3/8 | 11 3/8 | 11 3/25 | 3 | 3 | 3/4 | 8 | 130 |
| 8 | 19 1/2 | 11 3/4 | 13 1/2 | 7/8 | 8 | 8 3/8 | 2 7/8 | 2 | 15 3/4 | 16 | 5 3/4 | 5 3/4 | 3/4 | 8 | 250 |
| 10 | 24 1/2 | 14 1/4 | 16 | 1 9/50 | 10 | 10 3/4 | 3 1/8 | 1/2 | 17 | 21 | 5 3/4 | 5 3/4 | 7/8 | 12 | 430 |
| 12 | 27 1/2 | 17 | 19 | 1 1/4 | 12 | 12 1/2 | 3 7/16 | 3 1/2 | 22 1/2 | 24 | 6 1/2 | 6 1/2 | 7/8 | 12 | 660 |
| 14 | 31 | 18 3/4 | 21 | 1 3/8 | 14 | 13 | 3 5/8 | 4 | 26 1/4 | 23 1/4 | 6 1/2 | 6 1/2 | 1 | 12 | 750 |
| 16 | 32 | 21 1/4 | 23 1/2 | 1 7/16 | 16 | 14 1/4 | 3 1/4 | 4 5/8 | 30 | 25 1/4 | 6 1/2 | 6 1/2 | 1 | 16 | 900 |
| 16 | 36 | 21 1/4 | 23 1/2 | 1 7/16 | 16 | 14 1/4 | 3 1/4 | 4 5/8 | 30 | 25 1/4 | 6 1/2 | 6 1/2 | 1 | 16 | 900 |
| 18 | 36 | 22 3/4 | 25 | 1 9/16 | 18 | 15 1/4 | 3 1/8 | 5 1/4 | 33 3/4 | 28 1/4 | 6 1/2 | 6 1/2 | 1 1/8 | 16 | 1230 |
| 18 | 40 | 22 3/4 | 25 | 1 9/16 | 18 | 15 1/4 | 3 1/8 | 5 1/4 | 33 3/4 | 28 1/4 | 6 1/2 | 6 1/2 | 1 1/8 | 16 | 1230 |
| 20 | 40 | 25 | 27 1/2 | 1 11/16 | 20 | 16 7/8 | 3 1/2 | 5 7/8 | 37 1/2 | 30.63 | 8 | 8 | 1 1/8 | 20 | 1750 |
| 24 | 48 | 29 1/2 | 32 | 1 7/8 | 24 | 19 1/4 | 5 | 1 81/100 | 45 | 36 | 8 | 8 | 1 1/4 | 20 | 2400 |
| 30 | 56 | 36 | 38 3/4 | 2 3/25 | 30 | 23 | 5 3/4 | -5/8 | 41 1/4 | 45 7/8 | 8 | 8 | 1 1/4 | 28 | 4350 |
| 30 | 56 | 36 | 38 3/4 | 2 3/25 | 30 | 23 | 5 3/4 | -5/8 | 41 1/4 | 45 7/8 | 8 | 8 | 1 1/4 | 28 | 4350 |
| 36 | 63 | 42 3/4 | 46 | 2 3/8 | 36 | 27 3/8 | 3 7/8 | -3/8 | 49 | 55 | 9 3/4 | 9 3/4 | 1 1/2 | 32 | 7000 |
| 36 | 63 | 42 3/4 | 46 | 2 3/8 | 36 | 27 3/8 | 3 7/8 | -3/8 | 49 | 55 | 9 3/4 | 9 3/4 | 1 1/2 | 32 | 7000 |
| 42 | 70 | 49 1/2 | 53 | 2 16/25 | 42 | 36 7/8 | 3/25 | -5 1/2 | 53 1/2 | 60 9/50 | 9 3/4 | 9 3/4 | 1 1/2 | 36 | 9410 |
| 42 | 70 | 49 1/2 | 53 | 2 16/25 | 42 | 36 7/8 | 3/25 | -5 1/2 | 53 1/2 | 60 9/50 | 9 3/4 | 9 3/4 | 1 1/2 | 36 | 9410 |
| 48 | 76 | 56 | 59 1/2 | 2 3/4 | 48 | 40 33/50 | 3/25 | -2 9/10 | 41 49/50 | 68 | 10 | 10 | 1 1/2 | 44 | 12700 |
| 48 | 76 | 56 | 59 1/2 | 2 3/4 | 48 | 40 33/50 | 3/25 | -2 9/10 | 41 49/50 | 68 | 10 | 10 | 1 1/2 | 44 | 12700 |

*Dimension "H" Does Not Extend Past Flange on Valve Sizes 2" Thru 3"

Material Description on Reverse

| Part No. | Description | Material | Part No. | Description | Material |
|-----------------|--------------------|--|-----------------|----------------------|---------------------------------|
| 1 | Body | Ductile Iron ASTM A536, Grade 65-46-12 | 5A | Cover Bolt | Alloy Steel SAE Grade 5, Plated |
| 2 | Cover | Ductile Iron ASTM A536, Grade 65-45-12 | 5B | Nut | Alloy Steel SAE Grade 5, Plated |
| 3 | Disc | Buna-N® w/ Alloy Steel & Nylon Reinforcement | 5C | Washer | Alloy Steel SAE Grade 5, Plated |
| 4 | Cover Seal | Buna-N® or Compressed Non-Asbestos Fiber | 6 | Return Flow Actuator | Brass |