

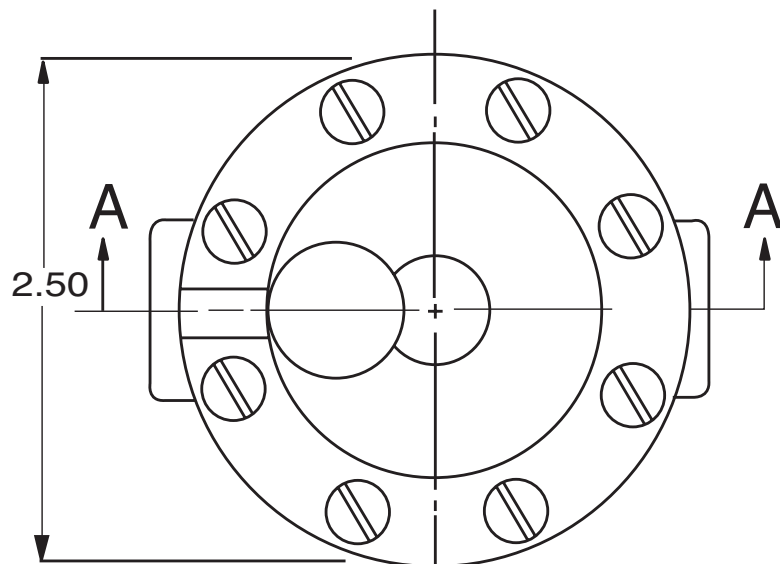

81-01

3/8" Check Valve



ITEM	DESCRIPTION
1.	Cover Screw (8 Required)
2.	Cover
*3.	Spring
4.	Diaphragm Washer
*5.	Diaphragm
*6.	Disc Retainer Assembly
7.	Body Plug (3/8 NPT)
8.	Body (Threaded)

*Recommended Spare Parts

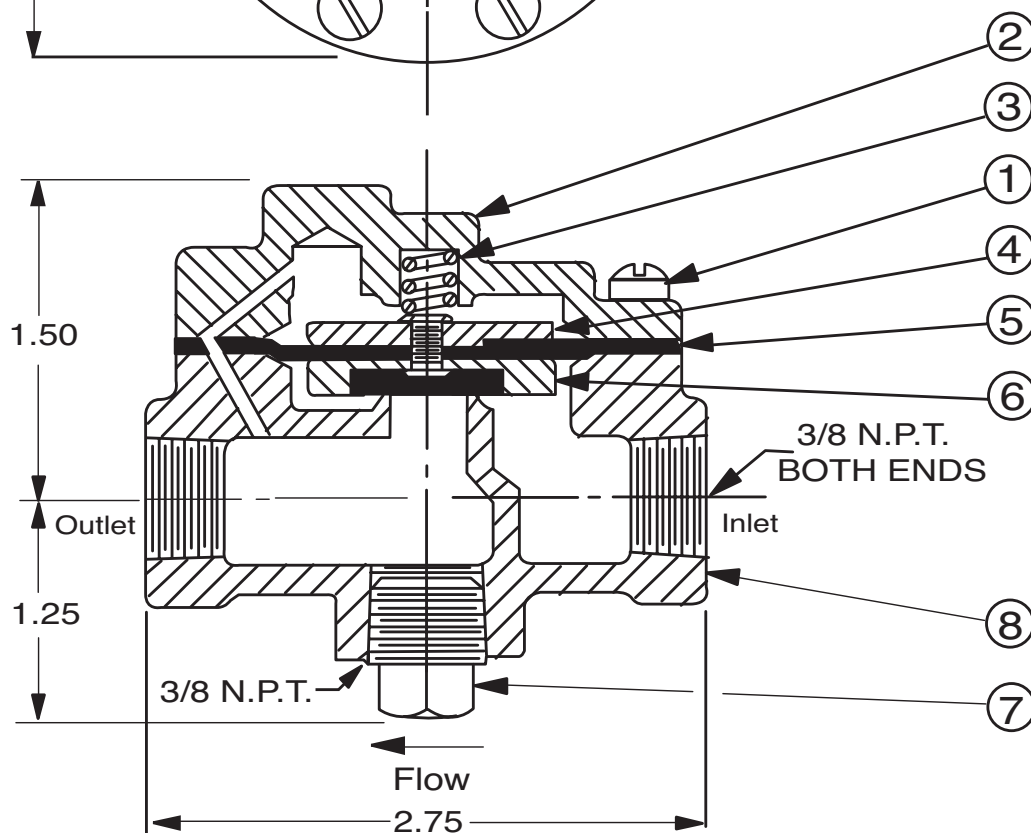

SECTION AA

When ordering parts, please specify:

- All nameplate data
- Description
- Part Number
- Item Number
- Material



81-01

1/2" & 3/4 Check Valve

ITEM DESCRIPTION

1.	Body	1
2.	Cover	1
*3.	Diaphragm	1
4.	Guide Disc	1
*5.	Disc Retainer Assembly	1
7.	Nut Hex 3/8 - 24UNF 28	1
8.	Plug Pipe Hex NPT	2
9.	Screw, Fil HD 10 32UNF 2 x 2LG	8
10.	Spring	1
11.	Nameplate	1

*Recommended Spare Parts

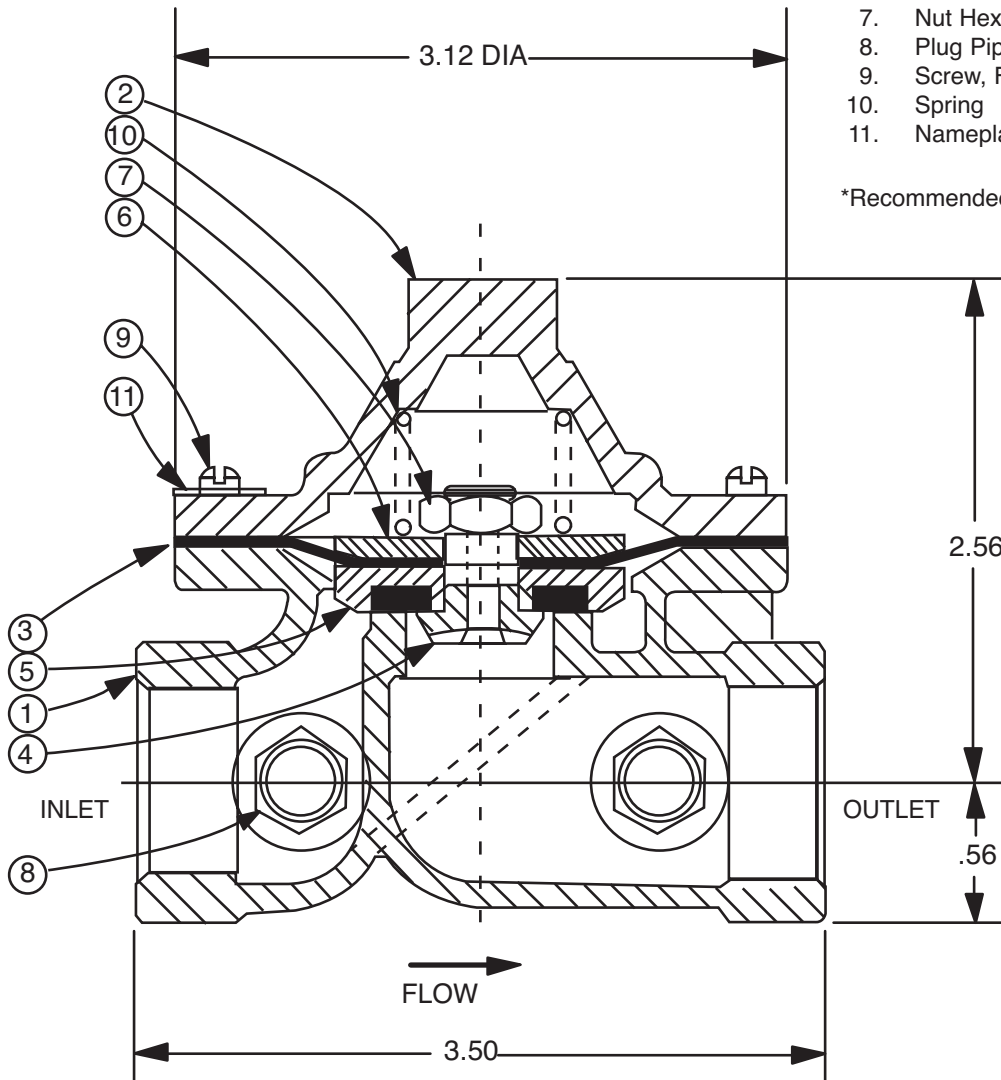

When ordering parts, please specify:

- All nameplate data
- Description
- Part Number
- Item Number
- Material