

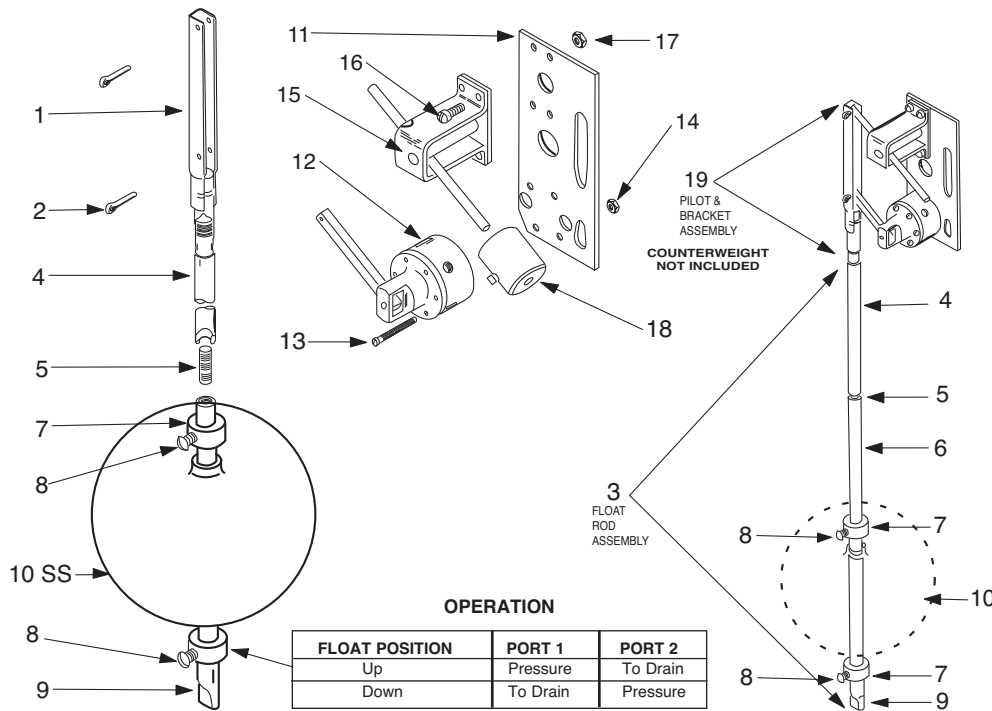

CF1-C1

Float Control



When ordering parts, please specify:

- All nameplate data
- Description
- Item Number

| ITEM | DESCRIPTION | PART No. | PRICE |
|-----------------------------------|-----------------------------------------------------------------------------------|------------------|-------|
| 1 | Link Assembly | V8316B | |
| 2 | Cotter Pins (2 required) | 20175227D | |
| 3 | Float Rod Assembly (2 ft.) (Item No. 4 thru 9) | 8829902LK | |
| 4 | Upper Float Rod (1 ft.) | Consult Factory | |
| | Upper Float Road (2 ft.) | 88298F | |
| 5 | Stud (Required for connecting upper and lower rods and on for each extension rod) | 88264H | |
| 6 | Extension Float Rod (1 ft.) | Consult Factory | |
| | Extension Float Rod (2 ft.) | 88297H | |
| 7 | Stop Collar (2 required) | 38097C | |
| 8 | Set Screw (1 for ea Stop Collar) SS | 6798837J | |
| 9 | Lower Float Rod (1 ft.) | 88297H | |
| | Lower Float Rod (2 ft.) | 88292J | |
| 10 | Float Ball (Optional Plastic) | C9253A | |
| 10 SS | Float Ball Stainless Steel (Standard) | C0648A | |
| 11 | Base and Mounting Plate (SS) | V6369A | |
| 12 | Pilot Valve Assembly CF1-C1 | 10529G | |
| 13 | Machine Screw 6/32 x 1-1/2" (6 req'd) | 6757530J | |
| 14 | Hex Nut 6/32 (6 req'd) | 678206K | |
| 15 | Counter Balance Bracket Assembly | 45385C | |
| 16 | Machine Screw 10/32 x 9/16" (4 req'd) | 6757822K | |
| 17 | Hex Nut 10/32 (4 req'd) | 6779506C | |
| 18 | Counterweight (varies with rod length, includes set screw) | 2-6' V006903J | |
| 19 | Pilot & Bracket Assembly CF1-C1 | Consult Factory | |
| COUNTERWEIGHT NOT INCLUDED | | | |

Optional Plastic Steel Float

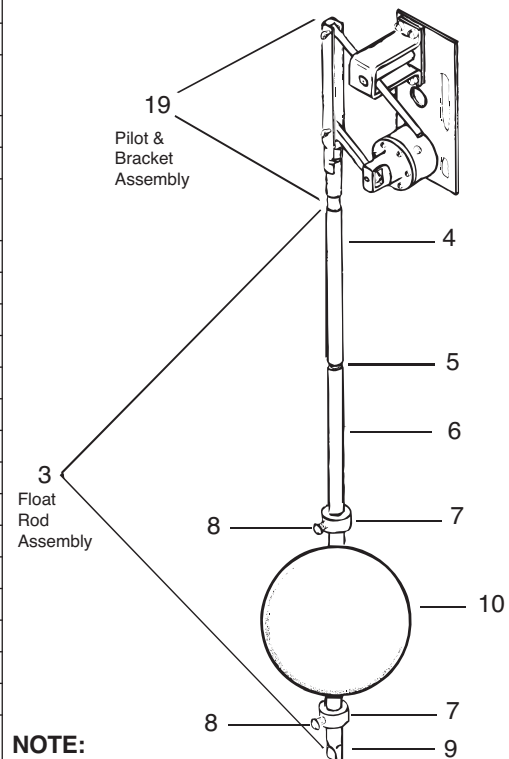

NOTE:

A stilling well (Min. 8" I.D.) must be provided around the float if the liquid surface is subject to turbulence, ripples or wind.



CF1 Series

CF1 Series Float Controls

Initial Adjustment CF1 Series Float Controls

Check installation to be sure that liquid surface is not subject to wind or currents, if so, a stilling well should be installed around the float and rod assembly. A short section of 8" pipe (PVC) mounted vertically in the tank around the float and rod is suggested.

1. See parts sheet (other side of this sheet) for proper assembly of the float rod, float, and stop collars and for threading into the Link Assembly of the CF1-C1.

2. Balance the Float Rod Assembly. This compensates for the buoyancy of the float rod in the water. Temporarily remove float by removing float rod and float from the link assembly. Remove float from float rod, reinstall rod assembly (leave stop collars on float rod) back into link assembly.

Adjust counterweight on rod to balance the weight of the float rod assembly less the float. Loosen setscrew on counterweight and move weight in or out round rod remains horizontal without shifting. Tighten setscrew. Check by pushing up or down on float rod assembly and seeing that entire assembly returns to balanced position. Replace float between the stop collars. The counterweight size changes as float rod is lengthened. Consult factory for more information.

3. Set Float High Level Shut-Off. Move float rod to "up" position. Adjust the upper stop collar on the float rod assembly approximately three inches above the desired high water level. Move float rod to "down" position. Adjust the lower stop collar on the float rod assembly approximately three inches below the desired low water level. Tighten collar set screws.

4. If the closing level is too high, allowing tank to overflow, then the top stop collar on the float rod should be lowered. If the opening level is too low, then the bottom stop collar should be raised.

If the counterweight has been properly adjusted the float will move freely on the float rod, without causing the pilot arm to raise or lower, until the float actually contacts one of the stop collars.

5. For reference: with a new control and supply pressure less than 40 psi the maximum level differential available will be: 18 to 20 inches with PVC float and rod assembly and 48 to 50 inches with Stainless Steel or Brass float and rod assembly.

Installation Data

The float control is mounted above the high water level in the tank. The valve is installed in the line leading to the tank and is connected to the float control pilot by tubing. (Min. 3/8" tubing)

When line pressure is used to operate the valve, tubing connections are made from the float control pilot to the valve cover, and also to the inlet side of the valve. An X43 "Y" Strainer or X46 Flow Clean Strainer must be installed in the inlet side of the valve. The control may be installed at any elevation above the valve, providing that the flowing line pressure in psi is equal to, or greater

than, the vertical distance in feet between the valve and the float control. An independent source of air or water may be used to operate the valve. The pressure from this independent source must constantly be equal to or greater than pressure at the valve inlet. The independent source is connected to the float control pilot in place of the supply line connected to the inlet side of the valve. If the Model 100-01 under the control of the CF1-C1 is 8" or larger, auxiliary Hytrols may be required. Consult factory for details.

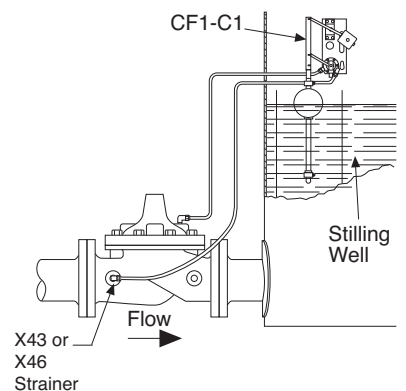

NOTE:

A stilling well (Min. 8" I.D.) must be provided around the float if the liquid surface is subject to turbulence, ripples or wind.

Note: We recommend protecting Float Control tubing and valve from freezing temperatures.