

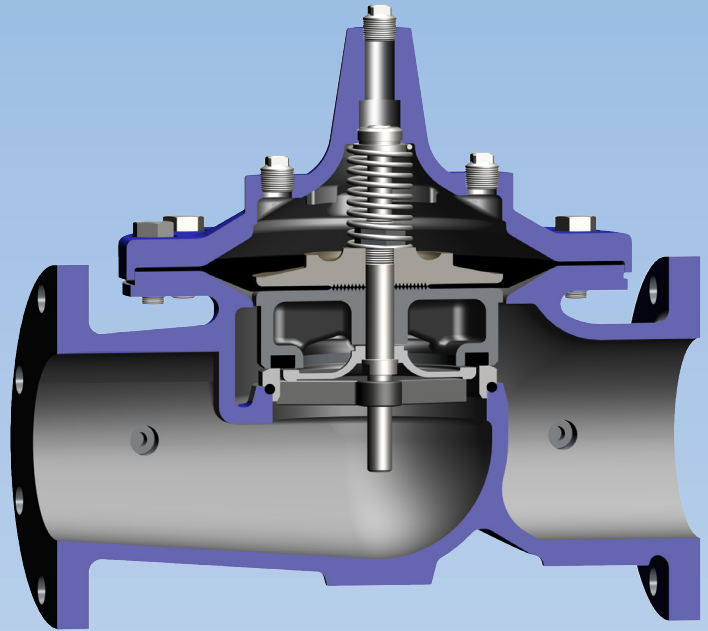

Inside CLA-VAL Automatic Control Valves

*Basic Main Valve
Non-Modulating Controls
Modulating Controls
Automatic Controls
Anti-Cavitation Operation*



Main Valve with Standard Trim

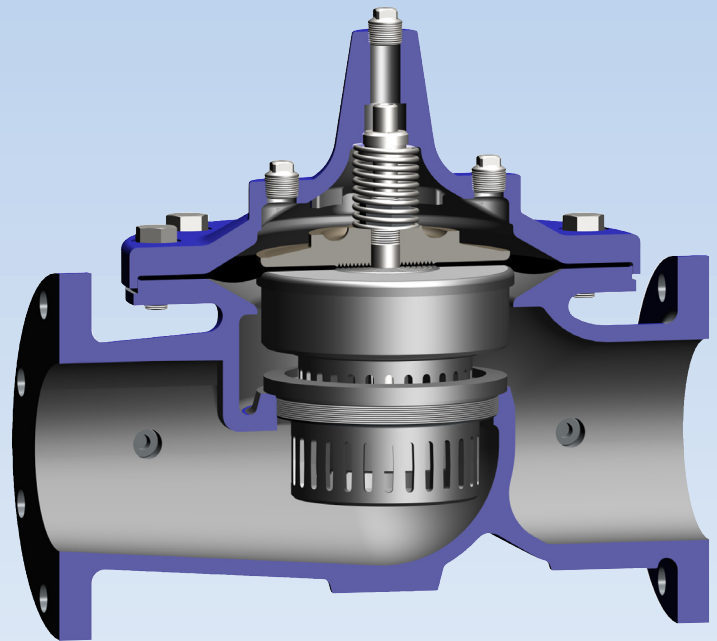

Main Valve with KO Anti-Cavitation Trim

BASIC MAIN VALVE

Most CLA-VAL valves consist of a main valve and pilot control system. The basic main valve is called a Hytrol Valve.

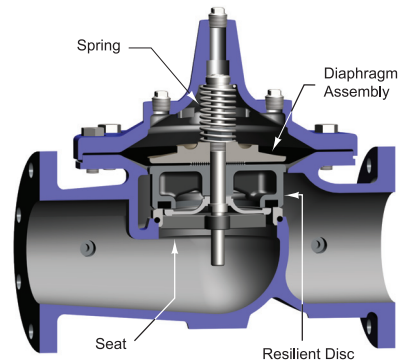
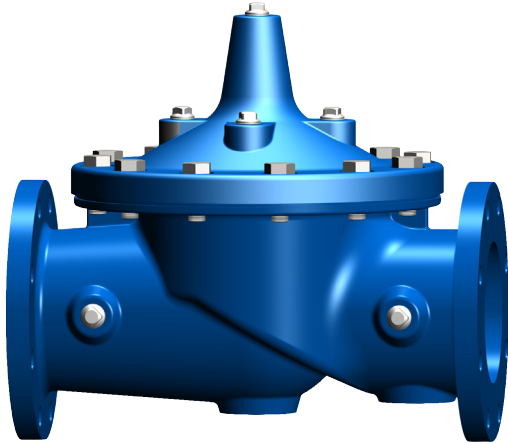

When no pressure is in the valve, the spring and the weight of the diaphragm assembly hold the valve closed.

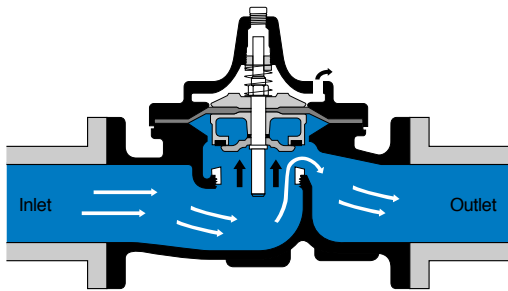

With the cover chamber vented to atmosphere, the valve will open from line pressure under the disc.

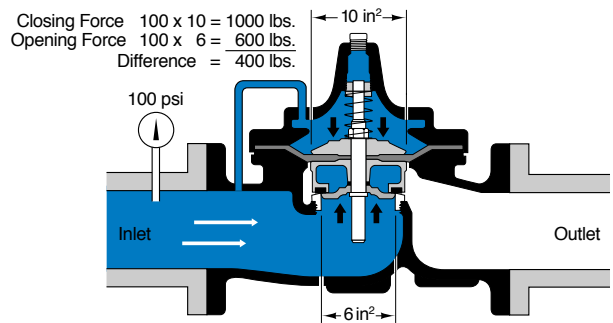

If inlet pressure is connected into the cover chamber, the valve closes tightly. In this example, the 400 pound difference is the force which pushes the disc against the seat and causes the valve to seal drip-tight.

NON-MODULATING CONTROLS

A simple control which either opens the valve wide or closes it tightly is a three-way valve. The type of operation this control gives is called "non-modulating" because the valve cannot pause in a partially open position.

Once the control is turned to either position, operating fluid flow into or out of the cover chamber until the valve is open or closed. For example...

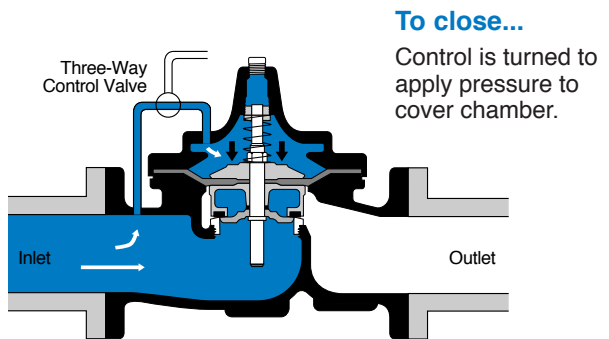
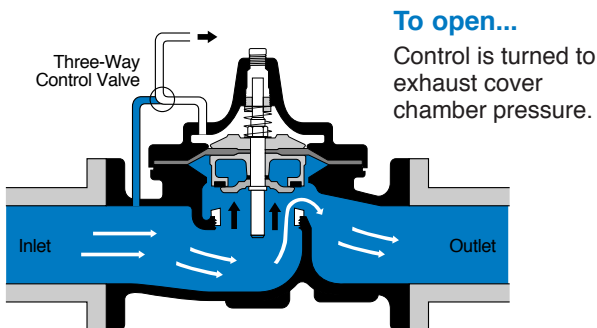

Ordinary three-way valves usually are not satisfactory because they require so much force to operate. An easy-turning control which can be operated in a variety of ways is usually used. Several examples of controls and their operation are shown at right.

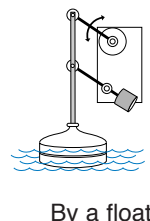
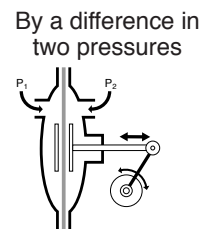
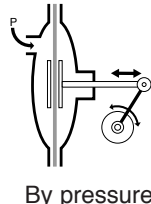
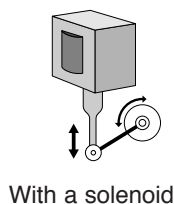

MODULATING CONTROLS

The Cla-Val Automatic Control Valve modulates if the cover pressure is held between the inlet and outlet pressure. To achieve modulating operation, a slightly different type of control system is utilized.

Valve Open

When the throttling control opens to a point where more pressure is relieved from the cover chamber than the restriction can supply, cover pressure is reduced and the valve opens.

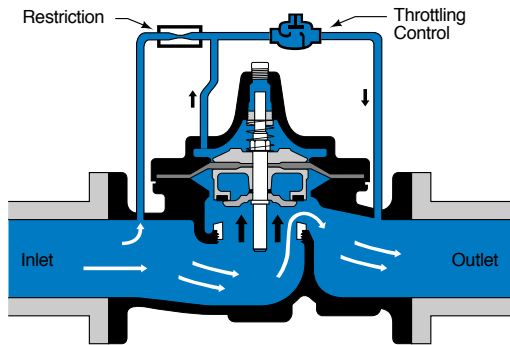

Valve Closed

When the modulating control closes sufficiently to direct a great enough pressure into the cover chamber to overcome opening forces of line pressure, the main valve closes.

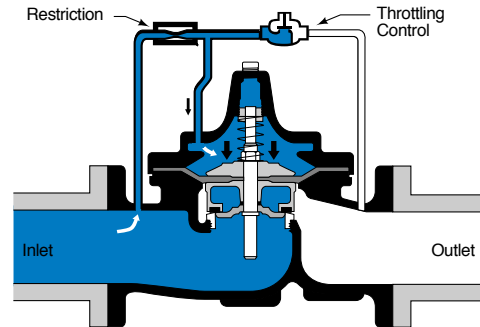

Valve Throttling

The main valve modulates to any degree of opening in response to changes in the throttling control. At an equilibrium point, the main valve opening and closing forces hold the valve in balance. This balance holds the valve partially open, but immediately responds and readjusts its position to compensate for any change in the controlled condition.

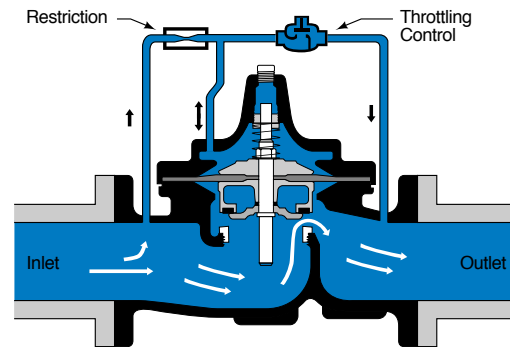

AUTOMATIC CONTROLS

The following examples illustrate several different types of operation utilizing automatic controls.

Pressure Reduction

Outlet pressure on control diaphragm causes the main valve to hold a steady outlet pressure.

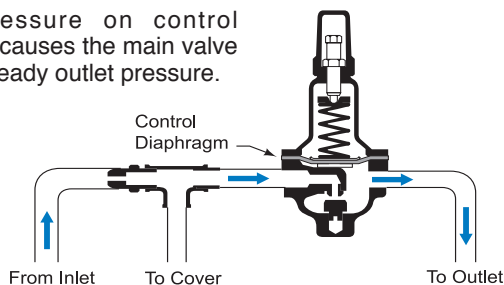

Liquid Level Controller

Slight changes in flow through the float control causes main valve to counteract changes in reservoir level so liquid level is held constant.

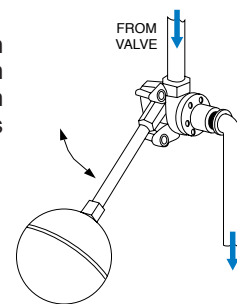

Pressure Relief

Inlet pressure on control diaphragm causes the main valve to hold a steady inlet pressure.

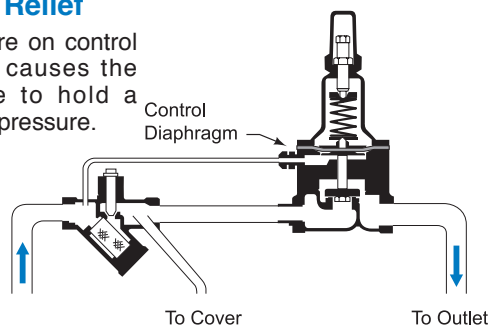

Rate of Flow Controller

Limits the maximum flow rate by changes to the main valve counteract any slight changes in differential pressure across an orifice plate located in the main line.

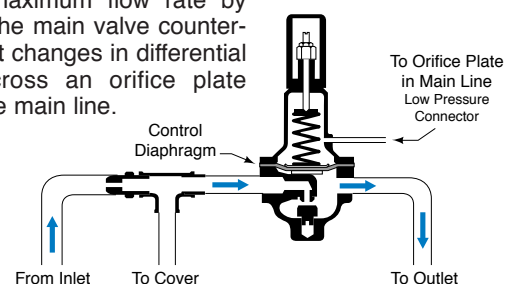

KO ANTI-CAVITATION OPERATION

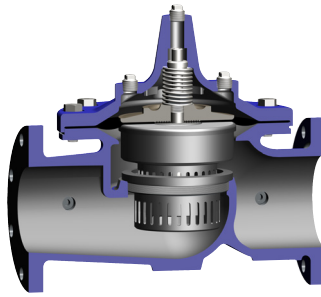

*KO Anti-Cavitation
Internal Trim*

First Stage Pressure Reduction

- Flow enters through the seat

Second Stage Pressure Reduction

- Flow impinges upon itself within the seat and disc guide assembly to dissipate cavitation and further reduce pressure

Third Stage Pressure Reduction

- Flow exits through the disc guide for final pressure reduction
- Diagonal disc guide slots direct flow away from surfaces.

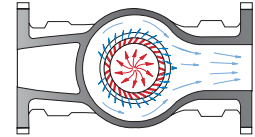
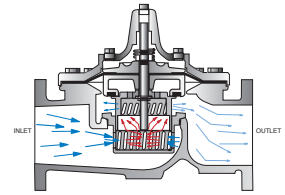

Q&A

Q Which way should fluid flow through a CLA-VAL Valve?

A Just as with any globe valve, the usual way is “under-the-disc” as shown. The main exception to the “under-the-disc” rule of thumb is the check valve.

“Under-the-Disc”

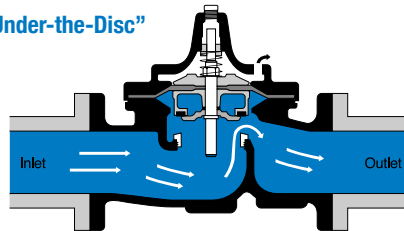

Standard Flow

Normal so valve closes against the pressure

“Over-the-Disc”

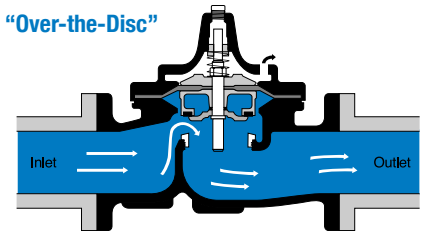

Reverse Flow

Acceptable only under specific conditions

Q What purpose does the internal spring in the Hytrol valve serve?

A To provide enough force to close the valve when no difference exists between inlet, cover and outlet pressures. When the inlet pressure is greater than outlet pressure (even by a small amount) the hydraulic forces, -- NOT THE SPRING hold the valve tightly closed.

Q Can pressure other than line pressure be used to operate CLA-VAL Valves?

A Yes. Frequently, when line fluid is too dirty or otherwise unsuitable, a separate source of pressure is desired. Clean water, air (with some limitations), or oil are suitable. The important point is to make sure the operating pressure is equal or greater than inlet pressure AT ALL TIMES.

Q What should be done if line pressure is very low? (Below 10 psi)

A Usually a separate source of operating pressure is required. A spring to open the valve may be necessary. Consult the factory for recommendations.

Q Can the opening and closing speed of a CLA-VAL Valve be controlled?

A Yes. It is a matter of controlling the rate at which operating fluid flows into or out of the cover chamber.

Here is a typical valve equipped with both opening and closing speed controls. A simple needle valve can be used for these controls.

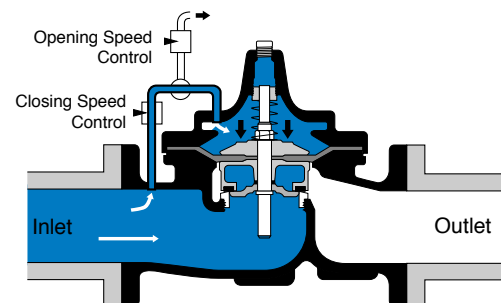

B-48 (R-04/06)

CLA-VAL

PO Box 1325 Newport Beach CA 92659-0325

800-942-6326 • Fax: 949-548-5441 • Web Site: cla-val.com • E-mail: claval@cla-val.com

CLA-VAL CANADA

4687 Christie Drive
Beamsville, Ontario
Canada LOR 1B4
Phone: 905-563-4963
Fax: 905-563-4040
E-mail sales@cla-val.ca

CLA-VAL EUROPE

Chemin des Mésanges 1
CH-1032 Romanel/
Lausanne, Switzerland
Phone: 41-21-643-15-55
Fax: 41-21-643-15-50
E-mail: cla-val@cla-val.ch

CLA-VAL UK

Dainton House, Goods Station Road
GB - Tunbridge Wells
Kent TN11 2 DH England
Phone: 44-1892-514-400
Fax: 44-1892-543-423
E-mail: info@cla-val.co.uk

CLA-VAL FRANCE

Porte du Grand Lyon 1
ZAC du Champ du Périer
France - 01700 Neyron
Phone: 33-4-72-25-92-93
Fax: 33-4-72-25-04-17
E-mail: cla-val@cla-val.fr

©COPYRIGHT CLA-VAL 2005 Printed in USA Specifications subject to change without notice.