



Model **100G-UBR/UBD**

Hydraulic On/Off Deluge Valve with Pressure Regulation

NOTE: 100G-UBD uses CDHS-2B pilot in place of CRD for differential control applications.



Description

The Cla-Val Model 100G-UBR is a hydraulically actuated on/off regulating deluge valve designed for use in multiple applications.

The 100G-UBR can be actuated locally by relieving cover pressure through our EDVR (Emergency Deluge Valve Release) or remotely based on customer design.

Once actuated, downstream pressure will be regulated to an adjustable set point.

100G-UBD: Once actuated, CDHS-2B pilot will use differential pressure to regulate downstream flow.

Main Valve Features

- Dual Guided Stem Internal for Consistent Linear Seating
- Tapered Metal Seat for Drip Tight Shut-off
- Replaceable 316 Stainless Steel Seat
- Single Internal Guided Assembly
- Proven Repeat Functionality in Harsh Conditions
- In-Line Maintenance

Optional UL Features

- X101 Valve Position Indicator
- X141 Pressure Gauges
- Pressure Switch Assembly
- X105 Limit Switch

Listings and Approvals



Actuation Method

- EDVR Manual Release
- Remote Hydraulic Actuation

Typical Applications

- Hydraulically Operated Systems
- System Pressure Regulation
- Foam Applications
- Automatic Deluge Systems
- Flow Control Applications



Hydraulic On/Off Deluge Valve with Pressure Regulation

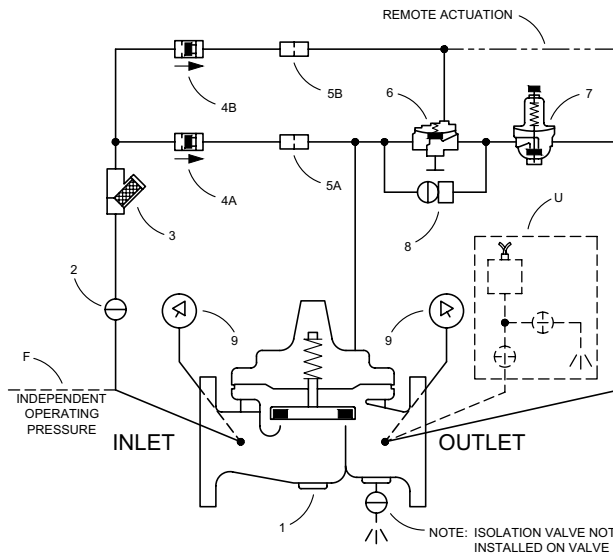

Schematic Diagram

Item	Description
1	UL Listed Valve
2	Isolation Valve
3	Strainer
4	Check Valve
5	Restriction Assembly
6	Auxiliary Hytrol (Rev. Flow)
7	Pressure Reducing Control
8	Emergency Deluge Valve Release
9	Pressure Gauge Assembly

Optional Features

Item	Description
F	Independent Operating Pressure
U	Pressure Switch Assembly

Cla-Val Model 100G-UBR is a hydraulically actuated on/off regulating deluge valve that opens or closes via local or remote actuation.

Closed Position: Supply pressure is applied through our Main Valve(1) Inlet Port or Independent Supply Line (F). The supply pressure will pass through our inlet isolation ball valve (2), strainer (3), check valve (4A) and restriction orifice (5A) before being applied to our Main Valve (1) Cover. Additionally the supply pressure will pass through our check valve (4B) and restriction orifice (5B) before applying pressure to the cover of our Auxiliary Hytrol.

Open Position: Main Valve (1) Cover pressure is released through our EDVR (Item 8) which consists of a quarter turn ball valve or via remote actuation per customer design. Once actuated, downstream pressure will be regulated to an adjustable set point.

Note: For seawater applications use 100GS/2100GS main valve

Main Valve Specifications

UL APPROVED SIZES

- Globe: 3" - 12" flanged
- Globe: 3" - 8" grooved
- Angle: 3" - 12" flanged

PRESSURE RATINGS

- 150 class, 250 psi maximum (Ductile Iron)
- 150 class, 285 psi maximum (All other materials)
- 300 class, 300 psi maximum (All materials)

TEMPERATURE RANGE

Water: to 180° F. Max

FLUIDS

Air, water, light oils

Materials

Main valve body & cover:

Standard Epoxy Coated Ductile Iron
ASTM A-536*

Main valve trim:

Stainless Steel

Pilot control system:

Cast Bronze

Rubber Parts:

Buna-N® Synthetic Rubber

Optional UL Listed Materials for Seawater and Severe Service Applications:

- **Nickel Aluminum Bronze (NAB)**
ASTM B148 Alloy C95800
- **Monel - QQ-N-288 Comp B**
ASTM A494 Grade M30H
- **Cast Steel**
ASTM A216 Grade WCB
- **316 Stainless Steel**
ASTM A743 Grades CF3M and CFM8
- **Super Austenitic Stainless Steel**
ASTM A351 Grade CK3MCuN (SMO 254)
- **Super Duplex Stainless Steel** ASTM A890
Grade 5A (CE3MN)

Functional Data

Valve Size	Inches	3	4	6	8	10	12	
	mm	80	100	150	200	250	300	
C _v Factor	Globe Pattern	Gal./Min. (gpm)	115	200	440	770	1245	1725
		Litres/Sec. (l/s)	27.6	48	105.6	184.8	299	414
	Angle Pattern	Gal./Min. (gpm)	139	240	541	990	1575	2500*
		Litres/Sec. (l/s)	33.4	58	130	238	378	600



Model **100G-UBR/UBD**

Hydraulic On/Off Deluge Valve with Pressure Regulation

Typical Applications

- Hydraulically Operated Systems
- System Pressure Regulation
- Foam Applications
- Automatic Deluge Systems
- Flow Control Applications

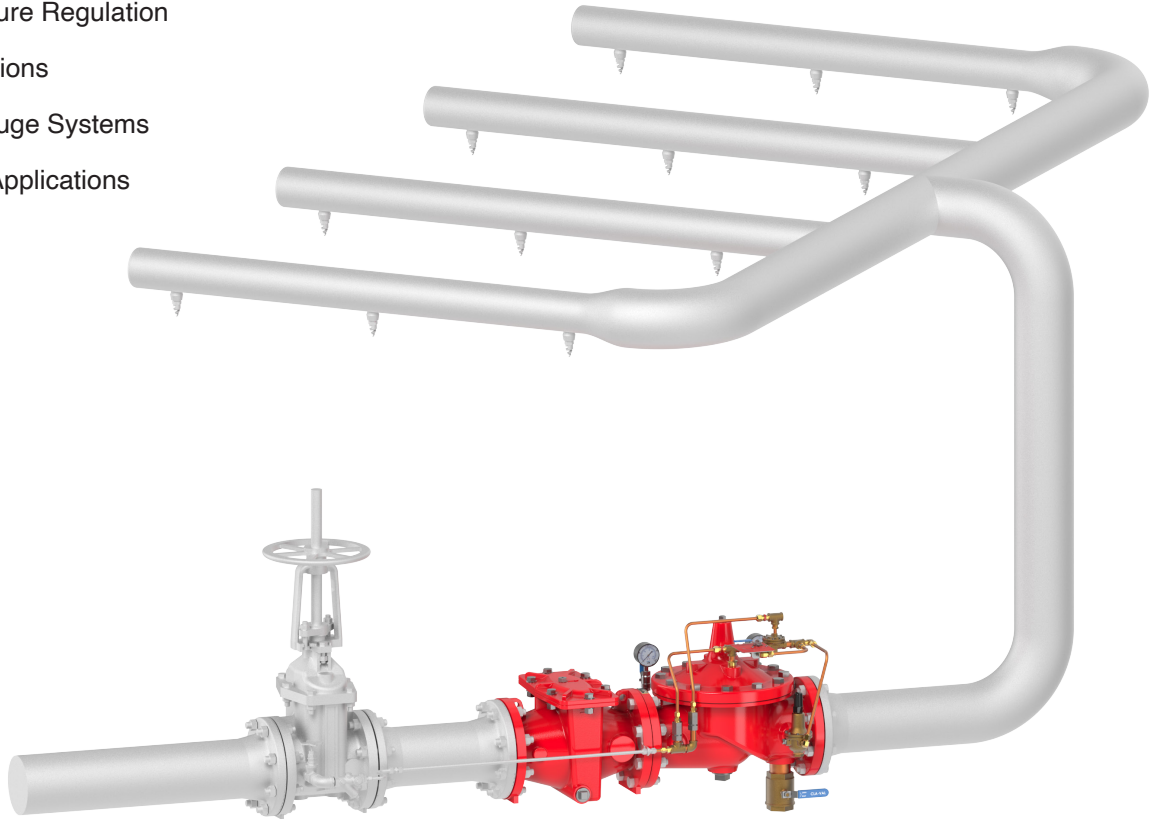

Optional Features



Position Indicator

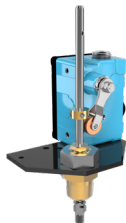

Limit Switch



Pressure Switch



Pressure Gauge

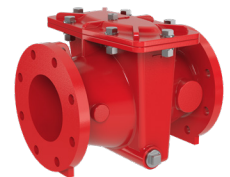

Strainer
(Not UL Listed)



Hydraulic On/Off Deluge Valve with Pressure Regulation

Dimensions

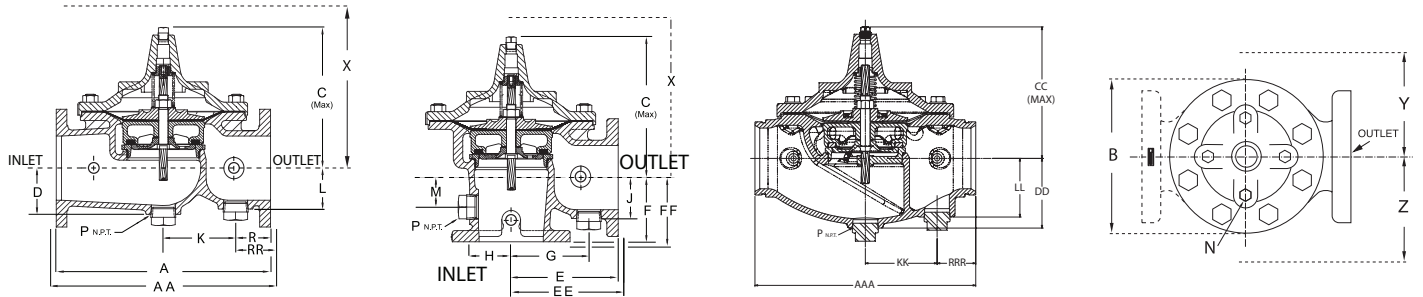

Unit	inches	mm	inches	mm	inches	mm	inches	mm	inches	mm	inches	mm
Valve Size	3	80	4	100	6	150	8	200	10	250	12	300
A 150 ANSI	12.00	305	15.00	381	20.00	508	25.38	645	29.75	756	34.00	864
AA 300 ANSI	13.25	337	15.62	397	21.00	533	26.38	670	31.12	791	35.50	902
AAA Grooved	12.50	318	15.00	381	20.00	508	25.38	645	—	—	—	—
B Dia.	9.12	232	11.50	292	15.75	400	20.00	508	23.62	600	28.00	711
C Max.	8.19	208	10.62	270	13.38	340	16.00	406	17.12	435	21.00	533
CC Max.	7.50	191	9.94	252	12.13	308	15.00	381	—	—	—	—
D	2.56	65	3.19	81	4.31	110	5.16	131	8.50	216	9.39	239
DD	3.62	92	4.50	114	6.31	160	7.81	198	—	—	—	—
E 150 ANSI	7.00	178	8.50	216	10.00	254	12.69	322	14.88	378	17.00	432
EE 300 ANSI	—	—	8.81	224	10.50	267	13.19	350	—	—	17.75	451
F 150 ANSI	4.00	102	4.97	126	6.00	152	8.00	203	8.62	219	13.75	349
FF 300 ANSI	—	—	5.28	134	6.50	165	8.50	216	—	—	14.50	368
L	2.56	65	2.81	71	3.81	97	4.81	122	8.50	216	9.39	239
LL	3.25	83	4.00	102	5.31	135	7.00	178	—	—	—	—
P NPT	1-1/4 - 11-1/2		2 - 11-1/2		2 - 11-1/2		2 - 11-1/2		2 - 11-1/2		2 - 11-1/2	
R 150 ANSI	2.50	64	3.47	88	3.25	83	4.19	106	7.12	181	6.50	165
RR 300 ANSI	3.12	79	3.78	96	3.75	95	4.69	119	7.81	198	7.25	184
RRR Grooved	2.75	70	2.94	75	3.50	89	5.69	145	—	—	—	—
X Pilot System	15.00	381	17.00	432	29.00	737	31.00	787	33.00	838	35.00	889
Y Pilot System	11.00	279	12.00	305	20.00	508	22.00	559	24.00	610	26.00	660
Z Pilot System	11.00	279	12.00	305	20.00	508	22.00	559	24.00	610	26.00	660

Model Number Codes



Size	Main Valve	Service	Trim	Body	Trim	Pilots	Tubing & Fittings	Elastomer	Flange	Face
3"	100 Globe	G Firewater	UBR	D Ductile Iron	S Stainless Steel	B Bronze w/SST	B Copper with Brass Fittings	B Buna	ANSI 150#	RF
4"	2100 Angle	GS Seawater	UBD	C Cast Steel	T 316 SS (F)	BM Bronze with Monel Internals	T 316 SS (F)	E EPDM	ANSI 300#	FF
6"		F Foam**(F)**		T 316 SS	M Bronze/Monel	T 316 SS (F)	M Monel	V Viton	ISO PN10	X Other
8"				N N.A.B.	U Super Duplex	M Monel	U 2507		ISO PN16	
10"				U Super Duplex	X Other	U Super Duplex	X Other		ISO PN25	
12"				X Other		X Other			V Grooved 300#	

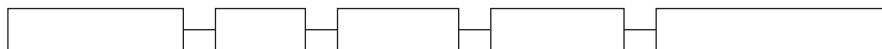

Restriction Orifice	Strainer	Check Valve	Hytrol	Optional Features
R0 None	S3 X43	0 None	0 None	F Indep. Operating Pressure
R58 X58C	S4 X44	CC CDC	H1 100-01	H Drain to Atmosphere
	S6 X46A	C8 81-01	H2 100-02	P Pressure Gauge Assembly
	S7 X47A	CS SW200	H2A 102F/X103	U Pressure Switch Assembly
				PT Pressure Transmitter
				LS Limit Switch
				PI Position Indicator
				TL Test Loop
				ADC Automatic Drip Check
				LPA Low Pressure Actuation
				CLF Controlled Line Fill