

Powertrol Valve

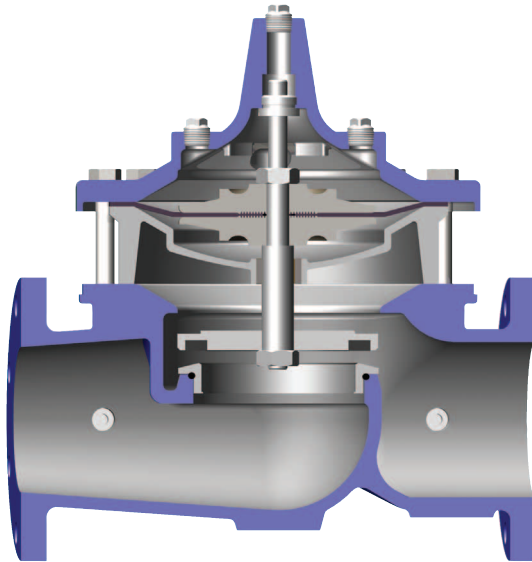

- Drip-Tight, Positive Seating
- Service Without Removal From Line
- Threaded or Flanged Ends
- Globe or Angle Pattern
- Every Valve Factory Tested

The Cla-Val Model 100-02 is a hydraulically operated, diaphragm actuated, globe, or angle pattern valve. It consists of four major components: body, intermediate chamber, diaphragm assembly, and cover. The diaphragm assembly is the only moving part.

The diaphragm assembly which is guided top and center by a precision machined stem, utilizes a non-wicking diaphragm of nylon fabric bonded with synthetic rubber. The diaphragm forms a seal between the cover chamber and intermediate chamber. A synthetic rubber disc retained on three and one half sides forms a drip-tight seal with the renewable seat when pressure is applied above the diaphragm. As pressure above the diaphragm is relieved and pressure is applied below the diaphragm, the valve opens wide for full flow. The rate of closing or opening can be controlled by modulating flow into or out of the diaphragm chambers.

The Model 100-02 is recommended where independent operating pressure is desired. Available in various materials and in a full range of sizes, with either threaded or flanged ends, its applications are many and varied.

Principle of Operation

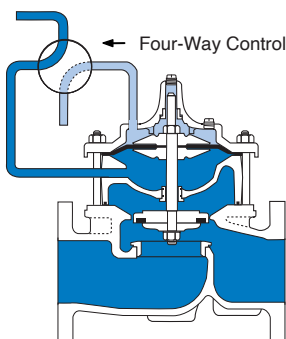

Full Open Operation

When operating pressure below the diaphragm is applied and operating pressure is relieved from the cover chamber and, the valve is held open, allowing full flow.

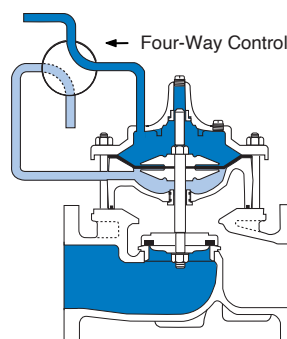

Tight Closing Operation

When pressure below the diaphragm is relieved and operating pressure is applied to the cover chamber, the valve closes drip-tight.

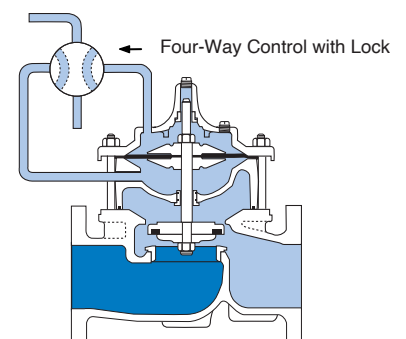

Modulating Action

The valve holds any intermediate position when operating pressure is equal above and below the diaphragm. A Cla-Val four-way pilot control with "lock" position can maintain this balance by stopping flow in the pilot control system.

Specifications

Available Sizes

Pattern	Threaded	Flanged	Grooved End
Globe	3/8" - 3"	1 1/2" - 24"	1 1/2"-2"- 2 1/2"- 3"- 4"- 6"- 8"
Angle	1 1/2" - 3"	2" - 16"	2" - 3" - 4"

Pressure Ratings (Recommended Maximum Pressure - psi)

Valve Body & Cover		Pressure Class			
		Flanged		Threaded	
Grade	Material	ANSI Standards*	150 Class	300† Class	End‡ Details
ASTM A536	Ductile Iron	B16.42	250	400	400
ASTM A216-WCB	Cast Steel	B16.5	285	400	400
UNS 87850	Bronze	B16.24	225	400	400

Note: * ANSI standards are for flange dimensions only.
 Flanged valves are available faced but not drilled.
 ‡ End Details machined to ANSI B2.1 specifications.
 † Consult factory when Maximum Operating Pressure Differential (MOPD) is greater than 400 PSID

"Valves for higher pressure are available; consult factory for details"

Materials

Component	Standard Material Combinations		
Body & Cover	Ductile Iron	Cast Steel	Bronze
Available Sizes	1 1/4" - 24"	1 1/4" - 16"	1 1/4" - 16"
Disc Retainer & Diaphragm Washer	Cast Iron	Cast Steel	Bronze
Trim: Disc Guide, Seat & Cover Bearing	Bronze is Standard Stainless Steel is Optional		
Disc	Buna-N® Rubber		
Diaphragm	Nylon Reinforced Buna-N® Rubber		
Stem, Nut & Spring	Stainless Steel		
For material options not listed, consult factory. Cla-Val manufactures valves in more than 50 different alloys.			

Options

Epoxy Coating - suffix KC

The NSF/ANSI 61 fusion bonded epoxy coating option is for use with cast iron, ductile iron or steel valves. This coating is resistant to various water conditions, certain acids, chemicals, solvents and alkalis. epoxy coatings are applied in accordance with AWWA coating specifications C116-03. Do not use with temperatures above 175° F

Viton® Rubber Parts - suffix KB

Optional diaphragm, disc and o-ring fabricated with Viton® synthetic rubber. Viton® is well suited for use with mineral acids, salt solutions, chlorinated hydrocarbons, and petroleum oils; and is primarily used in high temperature applications up to 250° F. Do not use with epoxy coating above 175°F.

Heavy Spring - suffix KH

The heavy spring option is used in applications where there is low differential pressure across the valve, and the additional spring force is needed to help the valve close. The option is best suited for valves used in on-off (non-modulating) service.

Operating Temp. Range

Fluids
-40° to 180° F

Model 100-02

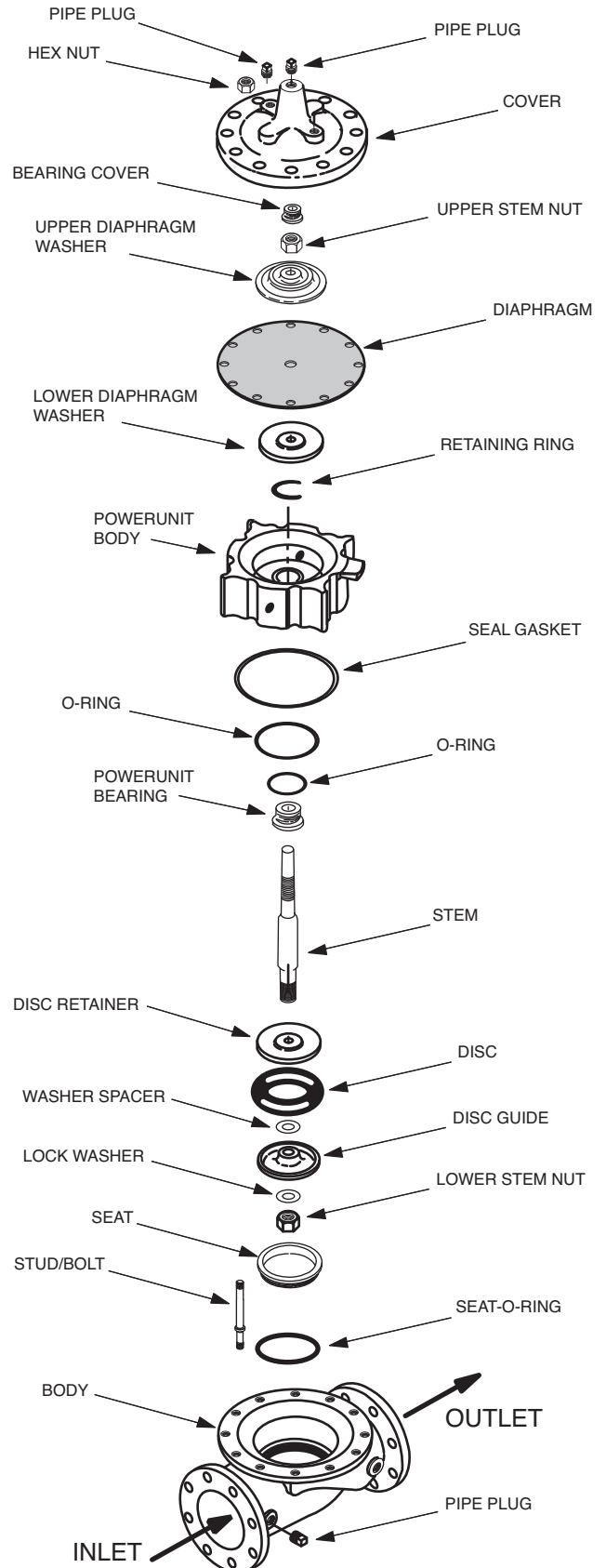

For assistance in selecting appropriate valve options or valves manufactured with special design requirements, please contact our Regional Sales Office or Factory.

Functional Data

Model 100-02

Valve Size		Inches	3/8	1/2	3/4	1	1 1/4	1 1/2	2	2 1/2	3	4	6	8	10	12	14	16	18	20	24	30	
C _V Factor	Globe Pattern	Gal./Min. (gpm.)	1.8	6	8.5	13.3	30	32	54	85	115	200	440	770	1245	1725	2300	3130	4450	5345	7655	10150	
		Litres/Sec. (l/s.)	.43	1.44	2.04	3.2	7.2	7.7	13	20	28	48	106	185	299	414	553	752	1069	1284	1839	2439	
Equivalent Length of Pipe	Globe Pattern	Feet (ft.)	25	7	16	23	19	37	51	53	85	116	211	291	347	467	422	503	612	595	628	1181	
		Meters (m.)	7.6	2.2	4.8	7.1	5.7	12	15.5	16	26	35	64	89	106	142	129	154	187	181	192	552	
K Factor	Globe Pattern		16.3	3.7	5.7	6.1	3.6	5.9	5.6	4.6	6.0	5.9	6.2	6.1	5.8	6.1	5.0	5.2	5.2	4.6	4.0	5.3	
	Angle Pattern		—	—	—	—	—	7.1	4.4	3.3	4.1	4.1	4.1	3.7	3.6	2.9	2.8	2.6	—	—	—	—	
Liquid Displaced from Cover Chamber When Valve Opens	Fl. Oz.		.12	.34	.34	.70	—	—	—	—	—	—	—	—	—	—	—	—	—	—	—	—	
	U.S. Gal.		—	—	—	—	.02	.02	.03	.04	.08	.17	.53	1.26	2.51	4.0	6.5	9.6	11	12	29	42	
	ml		3.5	10.1	10.1	20.7	75.7	75.7	121	163	303	643	—	—	—	—	—	—	—	—	—	—	—
	Litres		—	—	—	—	—	—	—	—	—	—	—	2.0	4.8	9.5	15.1	24.6	36.2	41.6	45.4	109.8	197

*Estimated

C_V Factor

Formulas for computing C_V Factor, Flow (Q) and Pressure Drop (ΔP):

$$C_V = \frac{Q}{\sqrt{\Delta P}} \quad Q = C_V \sqrt{\Delta P} \quad \Delta P = \left(\frac{Q}{C_V} \right)^2$$

K Factor (Resistance Coefficient)

The Value of K is calculated from the formula: $K = \frac{894d^4}{C_V^2}$ (U.S. system units)

Equivalent Length of Pipe

Equivalent lengths of pipe (L) are determined from the formula: $L = \frac{Kd}{12f}$ (U.S. system units)

Fluid Velocity

Fluid velocity can be calculated from the following formula: $V = \frac{.4085 Q}{d^2}$ (U.S. system units)

Where:

C_V = U.S. (gpm) @ 1 psi differential at 60° F water or

C_V-l/s = (l/s) @ 1 bar (14.5 PSIG) differential at 15° C water

d = inside pipe diameter of Schedule 40 Steel Pipe (inches)

f = friction factor for clean, new Schedule 40 pipe (dimensionless) (from Cameron Hydraulic Data, 18th Edition, P 3-119)

K = Resistance Coefficient (calculated)

L = Equivalent Length of Pipe (feet)

Q = Flow Rate in U.S. (gpm) or (l/s)

V = Fluid Velocity (feet per second) or (meters per second)

ΔP = Pressure Drop in (psi) or (bar)

Model 100-02 Flow Chart (Based on normal flow through a wide open valve)

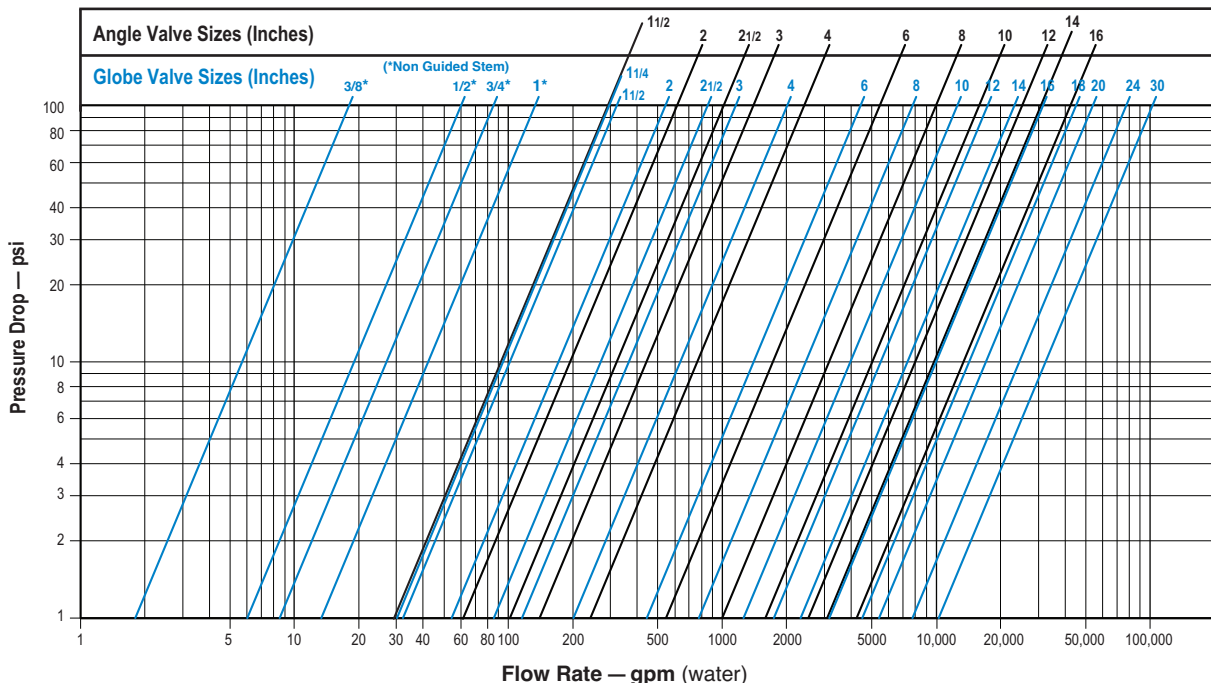

Dimensions

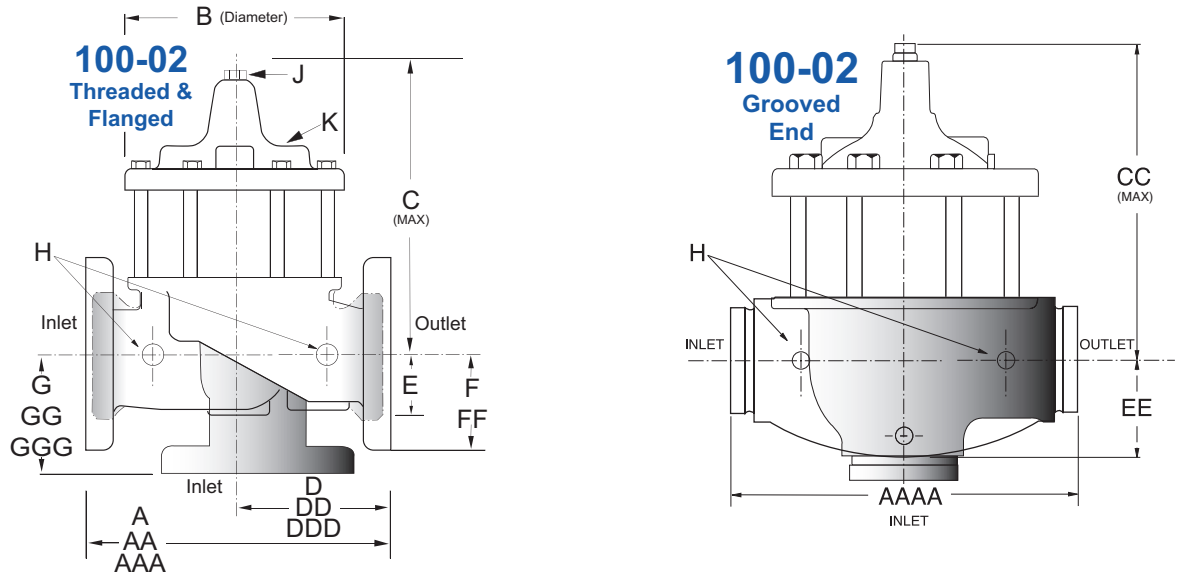

Valve Size (Inches)	3/8	1/2	3/4	1	1 1/4	1 1/2	2	2 1/2	3	4	6	8	10	12	14	16	18	20	24	30	
A Threaded	2.75	3.50	3.50	5.12	7.25	7.25	9.38	11.00	12.50	—	—	—	—	—	—	—	—	—	—	—	
AA 150 ANSI	—	—	—	—	—	8.50	9.38	11.00	12.00	15.00	20.00	25.38	29.75	34.00	39.00	41.38	46.00	52.00	61.50	63.00	
AAA 300 ANSI	—	—	—	—	—	9.00	10.00	11.62	13.25	15.62	21.00	26.38	31.12	35.50	40.50	43.50	47.64	53.62	63.24	64.50	
AAAA Grooved End	—	—	—	—	—	8.50	9.00	11.00	12.50	15.00	20.00	25.38	—	—	—	—	—	—	—	—	
B Diameter	2.50	3.12	3.12	4.38	5.62	5.62	6.62	8.00	9.12	11.50	15.75	20.00	23.62	28.00	32.75	35.50	41.50	45.00	53.16	56.00	
C Maximum	2.33	5.88	5.88	6.25	7.62	7.62	8.56	10.31	11.19	14.25	18.44	21.81	23.38	29.31	32.12	35.00	49.43	53.09	56.50	68.70	
CC Maximum Grooved End	—	—	—	—	—	6.87	7.81	9.63	10.25	13.50	17.18	20.43	—	—	—	—	—	—	—	—	
D Threaded	—	—	—	—	3.25	3.25	4.75	5.50	6.25	—	—	—	—	—	—	—	—	—	—	—	
DD 150 ANSI	—	—	—	—	—	4.00	4.75	5.50	6.00	7.50	10.00	12.69	14.88	17.00	19.50	20.81	—	—	—	—	
DDD 300 ANSI	—	—	—	—	—	4.25	5.00	5.88	6.38	7.88	10.50	13.25	15.56	17.75	20.25	21.62	—	—	—	—	
DDDD Grooved End	—	—	—	—	—	4.75	—	6.00	7.50	—	—	—	—	—	—	—	—	—	—	—	
E	1.25	0.88	0.88	1.63	1.12	1.12	1.50	1.69	2.06	3.19	4.31	5.31	9.25	10.75	12.62	15.50	12.95	15.00	17.75	21.31	
EE Grooved End	—	—	—	—	—	2.00	2.50	2.88	3.12	4.25	6.00	7.56	—	—	—	—	—	—	—	—	
F 150 ANSI	—	—	—	—	—	2.50	3.00	3.50	3.75	4.50	5.50	6.75	8.00	9.50	10.50	11.75	15.00	16.50	22.06	22.50	
FF 300 ANSI	—	—	—	—	—	3.06	3.25	3.75	4.13	5.00	6.25	7.50	8.75	10.25	11.50	12.75	15.00	16.50	22.90	24.00	
G Threaded	—	—	—	—	1.88	1.88	3.25	4.00	4.50	—	—	—	—	—	—	—	—	—	—	—	
GG 150 ANSI	—	—	—	—	—	4.00	3.25	4.00	4.00	5.00	6.00	8.00	8.62	13.75	14.88	15.69	—	—	—	—	
GGG 300 ANSI	—	—	—	—	—	4.25	3.50	4.31	4.38	5.31	6.50	8.50	9.31	14.50	15.62	16.50	—	—	—	—	
GGGG Grooved End	—	—	—	—	—	3.25	—	4.25	5.00	—	—	—	—	—	—	—	—	—	—	—	
H NPT Body Tapping	—	0.125	0.125	0.25	0.375	0.375	0.375	0.50	0.50	0.75	0.75	1.00	1.00	1.00	1.00	1.00	1.00	1.00	1.00	2.00	
J NPT Cover Center Plug	0.125	0.125	0.125	0.25	0.25	0.25	0.50	0.50	0.50	0.75	0.75	1.00	1.00	1.25	1.50	2.00	1.50	1.50	1.50	2.00	
K NPT Cover Tapping	—	0.125	0.125	0.25	0.375	0.375	0.375	0.50	0.50	0.75	0.75	1.00	1.00	1.00	1.00	1.00	1.00	1.00	1.00	2.00	
Valve Stem Int. Thread UNF	—	—	—	—	10-32	10-32	10-32	10-32	1/4-28	1/4-28	3/8-24	3/8-24	3/8-24	3/8-24	3/8-24	3/8-24	1/2-20	3/4-16	3/4-16	3/4-16	3/4-16
Stem Travel	—	—	—	—	0.40	0.40	0.60	0.70	0.80	1.10	1.70	2.30	2.80	3.40	4.00	4.50	5.10	5.63	6.75	7.50	
Approx. Ship Weight (lbs)	8	8	8	13	22	22	40	65	95	190	320	650	940	1675	2460	3100	4300	5400	8150	10300	

Note: The top two flange holes on valve size 36 are threaded to 1 1/2"-6 UNC.

Cla-Val Control Valves operate with maximum efficiency when mounted in horizontal piping with the main valve cover UP, however, other positions are acceptable. Due to component size and weight of 8 inch and larger valves, installation with cover UP is advisable. We recommend isolation valves be installed on inlet and outlet for maintenance. Adequate space above and around the valve for service personnel should be considered essential. A regular maintenance program should be established based on the specific application data. However, we recommend a thorough inspection be done at least once a year. Consult factory for specific recommendations.