

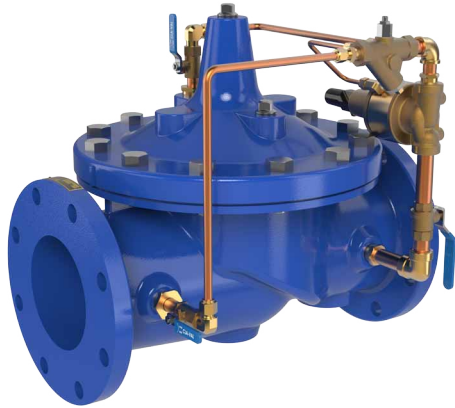

MODEL — 650-01

Pressure Relief & Pressure Sustaining Valve



Schematic Diagram

Item	Description
1	100-20 Hytrol Main Valve
2	X42N-2 Strainer & Needle Valve
3	CRL-60 Pressure Relief Control

Optional Features

Item	Description
B	CK2 Isolation Valve
D	Check Valves with Isolation Valve
F	Remote Pilot Sensing
H	Drain to Atmosphere
M	X144 e-FlowMeter
P	X141 Pressure Gauge
S	CV Speed Control (Opening)
V	X101 Valve Position Indicator

- Accurate Pressure Control
- Optional Check Feature
- Fast Opening to Maintain Line Pressure
- Slow Closing to Prevents Surges
- Completely Automatic Operation

The Cla-Val Model 650-01 Pressure Relief Valve is actuated by line pressure through a pilot control system, opening fast to maintain steady line pressure but closing gradually to prevent surges. Operation is completely automatic and pressure settings may be easily changed. This valve can be used for pressure relief, pressure sustaining, back pressure, or unloading functions in a bypass system.

If a check feature is added, and a pressure reversal occurs, the downstream pressure is admitted into the main valve cover chamber, closing the valve to prevent return flow.

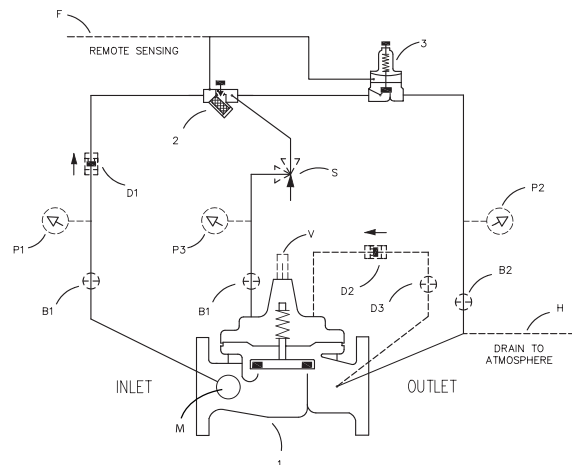

Typical Applications

Pressure Relief Service

This fast opening, slow closing relief valve provides system protection against high pressure surges on pump start up and pump shut down by dissipating the excess pressure to a safe location.

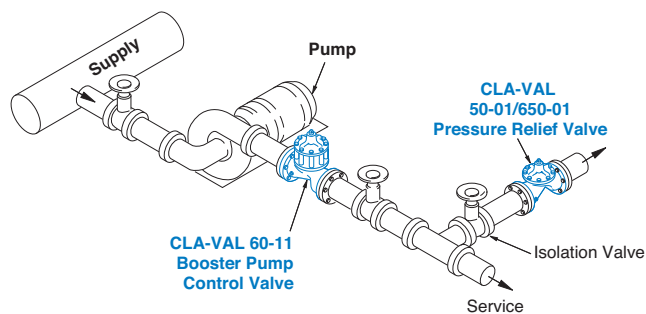

Pressure Sustaining Service

When installed in a line between an upper zone and a lower area of heavy demand, the valve acts to maintain desired upstream pressure to prevent "robbing" of the upper zone. Water in excess of pressure setting is allowed to flow to an area of heavy demand, control is smooth, and pressure regulation is positive.

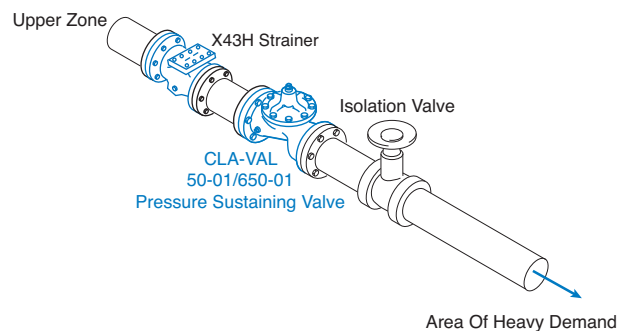

Model 650-01 (Uses 100-20 Hytrol Main Valve)

Pressure Ratings (Recommended Maximum Pressure - psi)

Valve Body & Cover		Pressure Class		
		Flanged		
Grade	Material	ANSI Standards*	150 Class	300 Class
ASTM A536	Ductile Iron	B16.42	250	400
ASTM A216-WCB	Cast Steel	B16.5	285	400
UNS 87850	Bronze	B16.24	225	400

Note: * ANSI standards are for flange dimensions only.
Flanged valves are available faced but not drilled.
Valves for higher pressure are available; consult factory for details

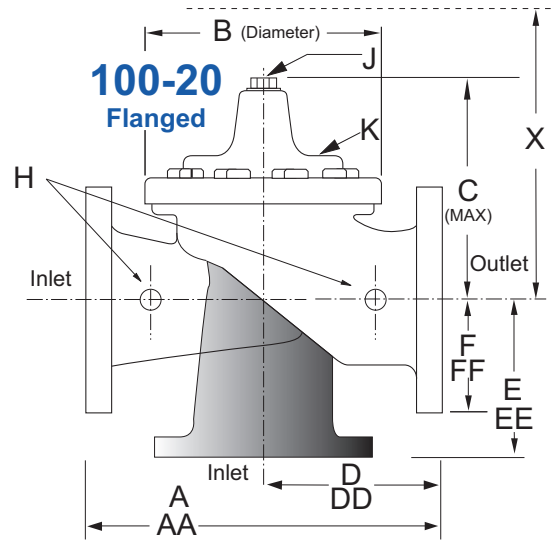

Materials

Component	Standard Material Combinations		
	Ductile Iron	Cast Steel	Bronze
Body & Cover	Ductile Iron	Cast Steel	Bronze
Available Sizes	3" - 48"	3" - 16"	3" - 16"
	80 - 1200 mm	80 - 400 mm	80 - 400 mm
Disc Retainer & Diaphragm Washer	Cast Iron	Cast Steel	Bronze
Trim: Disc Guide, Seat & Cover Bearing	Bronze is Standard Stainless Steel is Optional		
Disc	Buna-N® Rubber		
Diaphragm	Nylon Reinforced Buna-N® Rubber		
Stem, Nut & Spring	Stainless Steel		

For material options not listed, consult factory.
Cla-Val manufactures valves in more than 50 different alloys.

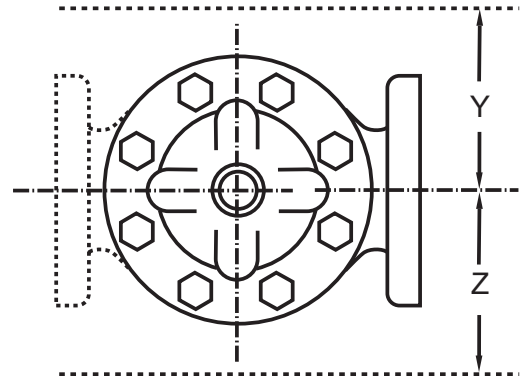

Model 650-01 Dimensions (In Inches)

Valve Size (Inches)	3	4	6	8	10	12	14	16	18	20	24	30	36	48
A 150 ANSI	10.25	13.88	17.75	21.38	26.00	30.00	34.25	35.00	42.12	48.00	48.00	63.25	65.00	88.0
AA 300 ANSI	11.00	14.50	18.62	22.38	27.38	31.50	35.75	36.62	43.63	49.62	49.75	63.75	67.00	90.62
B Diameter	6.62	9.12	11.50	15.75	20.00	23.62	27.47	28.00	35.44	35.44	35.44	53.19	56.00	66.00
C Maximum	7.00	8.62	11.62	15.00	17.88	21.00	20.88	25.75	25.00	31.50	31.50	43.94	54.75	59.00
D 150 ANSI	—	6.94	8.88	10.69	12.75	14.94	—	—	20.93	21.06	—	—	—	—
DD 300 ANSI	—	7.25	9.38	11.19	—	—	—	—	—	—	—	—	—	—
E 150 ANSI	—	5.50	6.75	7.25	8.06	8.68	—	—	15.81	15.94	—	—	—	—
EE 300 ANSI	—	5.81	7.25	7.75	—	—	—	—	—	—	—	—	—	—
F 150 ANSI	3.75	4.50	5.50	6.75	8.00	9.50	11.00	11.75	15.88	14.56	17.00	19.88	25.50	34.00
FF 300 ANSI	4.12	5.00	6.25	7.50	8.75	10.25	12.00	12.75	15.88	16.06	19.00	22.00	27.50	38.50
H NPT Body Tapping	0.375	0.50	0.75	0.75	1.00	1.00	1.00	1.00	1.00	1.00	1.00	1.00	2.00	2.00
J NPT Cover Center Plug	0.50	0.50	0.75	0.75	1.00	1.00	1.25	1.25	2.00	2.00	2.00	1.00	2.00	2.00
K NPT Cover Tapping	0.375	0.50	0.75	0.75	1.00	1.00	1.00	1.00	1.00	1.00	1.00	1.00	2.00	2.00
Stem Travel	0.60	0.80	1.10	1.70	2.30	2.80	3.40	4.50	4.50	4.50	6.50	7.50	7.50	8.50
Approx. Ship Weight (lbs)	45	85	195	330	625	900	1250	1380	2365	2551	2733	6500	8545	13100
Approx. X Pilot System	13	15	27	30	33	36	36	41	40	46	55	68	79	86
Approx. Y Pilot System	10	11	18	20	22	24	26	26	30	30	30	39	40	47
Approx. Z Pilot System	10	11	18	20	22	24	26	26	30	30	30	39	42	49

*Consult Factory

For sizes 18 through 36-inches, use the 650-66 E-Sheet

Model 650-01 Metric Dimensions (Uses 100-20 Hytrol Main Valve)

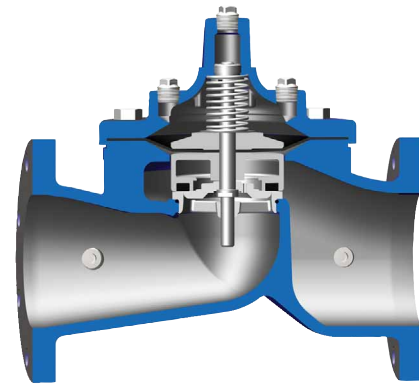
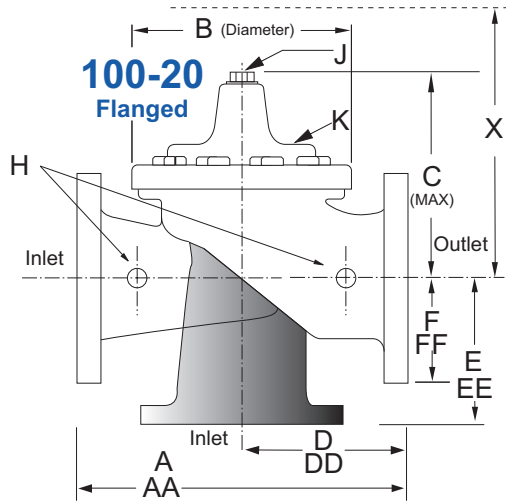

Model 100-20 Reduced Port Hytrol Main Valve

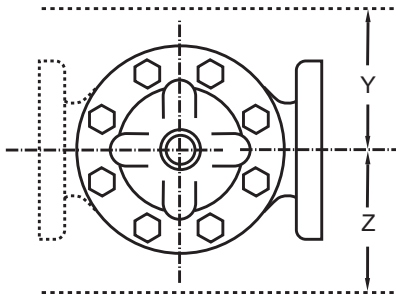

Model 650-01 Dimensions (In mm)

Valve Size (mm)	80	100	150	200	250	300	350	400	450	500	600	750	900	1200
A 150 ANSI	260	353	451	543	660	762	870	889	1070	1219	1219	1607	1651	2235
AA 300 ANSI	279	368	473	568	695	800	908	930	1108	1260	1263	1619	1702	2302
B Diameter	168	232	292	400	508	600	698	711	900	900	900	1351	1422	1676
C Maximum	178	219	295	381	454	533	530	654	635	800	800	1116	1391	1499
D 150 ANSI	—	176	226	272	324	380	—	—	532	535	—	—	—	—
DD 300 ANSI	—	184	238	284	—	—	—	—	—	—	—	—	—	—
E 150 ANSI	—	140	171	184	205	349	—	—	402	405	—	—	—	—
EE 300 ANSI	—	148	184	197	—	—	—	—	—	—	—	—	—	—
F 150 ANSI	95	114	140	171	203	241	279	289	403	370	432	505	648	864
FF 300 ANSI	105	127	159	191	222	260	305	324	403	408	483	559	699	978
H NPT Body Tapping	0.375	0.50	0.75	0.75	1.00	1.00	1.00	1.00	1.00	1.00	1.00	1.00	2.00	2.00
J NPT Cover Center Plug	0.50	0.50	0.75	0.75	1.00	1.00	1.25	1.25	2.00	2.00	2.00	1.00	2.00	2.00
K NPT Cover Tapping	0.375	0.50	0.75	0.75	1.00	1.00	1.00	1.00	1.00	1.00	1.00	1.00	2.00	2.00
Stem Travel	15	20	28	43	58	71	86	86	114	114	114	165	191	216
Approx. Ship Weight (kgs)	20	39	89	150	284	409	568	627	681	1157	1249	2951	3876	5942
Approx. X Pilot System	331	381	686	762	839	915	915	1042	1016	1169	1397	1728	2007	2185
Approx. Y Pilot System	254	280	458	508	559	610	661	661	762	762	762	991	1016	1194
Approx. Z Pilot System	254	280	458	508	559	610	661	661	762	762	762	991	1067	1245

*Consult Factory

650-01 Valve Selection	100-20 Pattern: Globe (G), Angle (A), End Connections: Flanged (F) Indicate Available Sizes															
	Inches	3	4	6	8	10	12	14	16	18	20	24	30	36	42	48
	mm	80	100	150	200	250	300	350	400	450	500	600	750	900	1000	1200
Main Valve 100-20	Pattern	G	G, A	G, A	G, A	G	G	G	G	G	G	G	G	G	G	G
	End Detail	F	F	F	F	F	F	F	F	F	F	F	F	F	F	F
Suggested Flow (gpm)	Maximum	260	580	1025	2300	4100	6400	9230	9230	16500	16500	16500	28000	42000	57000	57000
	Maximum Surge	440	990	1760	3970	7050	11000	15900	15900	28200	28200	28200	56500	67000	90000	90000
Suggested Flow (Liters/Sec)	Maximum	16	37	65	145	258	403	581	581	1040	1040	1040	1764	2115	3596	3596
	Maximum Surge	28	62	111	250	444	693	1002	1002	1777	1777	1777	3560	3700	5678	5678

100-20 Series is the reduced internal port size version of the 100-20 Series.

Notes:

- Many factors should be considered in sizing pressure relief valves including inlet pressure, outlet pressure and flow rates.
- For sizing questions or cavitation analysis, consult Cla-Val with system details.

Pilot System Specifications



Adjustment Ranges

- 0 to 75 psi Max.
- 20 to 105 psi
- 20 to 200 psi *
- 100 to 300 psi
- 250 to 600 psi

*Supplied unless otherwise specified. Other ranges are available, please consult factory.

Temperature Range

Water: to 180°F

Consult factory for hot water applications.

Materials

Standard Pilot System Materials

- Pilot Control: Low Lead Bronze
- Trim: Stainless Steel Type 303
- Rubber: Buna-N® Synthetic Rubber

Optional Pilot System Materials

Pilot Systems are available with optional Aluminum, Stainless Steel or Monel materials.

When Ordering, Specify:

1. Catalog No. 650-01
2. Valve Size
3. Pattern - Globe or Angle
4. Pressure Class
5. Threaded, Flanged, Grooved
6. Trim Material
7. Adjustment Range
8. Desired Options
9. When Vertically Installed

Main Valve Options

EPDM Rubber Parts

Optional diaphragm, disc and o-ring fabricated with EPDM synthetic rubber

Viton® Rubber Parts - suffix KB

Optional diaphragm, disc and o-ring fabricated with Viton® synthetic rubber

Epoxy Coating - suffix KC

NSF/ANSI 61 Fusion Bonded Epoxy Coating

Dura-Kleen® Stem - suffix KD

Fluted design prevents dissolved minerals build-up on the stem

LFS Trim

Designed to regulate precisely and smoothly at typical flow rates as well as lower than the industry standard of 1 fps, without decreasing the valve's capacity

Valve Options

X141 Pressure Gauge



X101AR Valve Position Indicator with Air Release



X101 Valve Position Indicator



X144 e-FlowMeter



X43H Strainer



Stainless Steel Pilot