



MODEL — **90-48**

Pressure Reducing Valve with Low Flow By-Pass



- **Modulating Control**
- **Maintains Constant Outlet Pressure Over a Wide Range of Flows**
- **Durable Construction**
- **Convenient and Space Saving**

The Cla-Val Model 90-48 Pressure Reducing Valve with Low Flow By-Pass automatically reduces a higher inlet pressure to a steady lower downstream pressure, regardless of changing flow rate. The low flow by-pass capability is achieved by using the Cla-Val Model CRD-L Direct Acting Pressure Reducing Valve as an integral part of the main valve. By doing this, space is saved and installation and maintenance become much easier.

The pressure reducing valve is hydraulically operated and controlled by a Cla-Val CRD pilot control, which senses pressure at the main valve outlet. An increase in outlet pressure forces the CRD pilot control to close and a decrease in outlet pressure opens the control. This causes the main valve cover pressure to vary, modulating the main valve, thereby, maintaining constant outlet pressure.

The Model CRD-L low flow pressure reducing by-pass is set to a higher pressure than the CRD pilot control. The CRD-L responds to pressure changes at the main valve outlet. When the CRD closes, the Model CRD-L remains open, allowing low flow to by-pass the main valve. The CRD-L closes when the flow decreases and the downstream pressure reaches its set-point .

The bypass size on this valve is limited by the body tapping size on the main valve. Consequently, in applications where higher flows for the low flow bypass may be required, such as building applications for off peak flows, a larger, separate bypass may be required. Refer to Cla-Val Model 90-99 as an option.

Schematic Diagram

Item	Description
1	100-01 Hytrol Main Valve
2	X47A Ejector
3	CRD Pressure Reducing Control
4	CRD-L Pressure Reducing Valve
5	CK2 Isolation Valve

Optional Features

Item	Description
A	X46A Flow Clean Strainer
B	CK2 Isolation Valve
C	CV Flow Control (Closing)*
D	Check Valves with Isolation Valve
P	X141 Pressure Gauge
S	CV Speed Control (Opening)*
V	X101 Valve Position Indicator
Y	X43 "Y" Strainer

*The optional closing speed control on this valve should always be open at least three (3) turns off its seat.

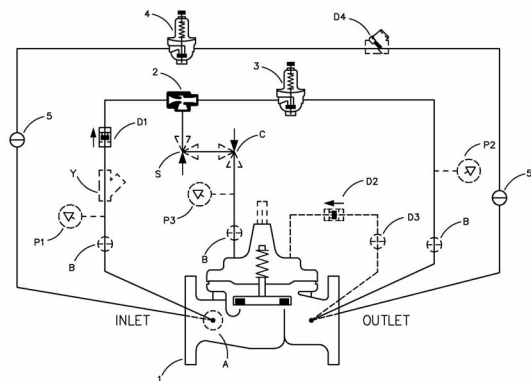

Typical Applications

This valve has the flexibility to be installed in a distribution system where the demand varies over a wide range. This frequently occurs in industrial, residential, educational, high-rise buildings and other applications.

Another important feature of the valve is its space efficient configuration, allowing easy installation and maintenance. A downstream pressure relief valve is also recommended for this type of application.

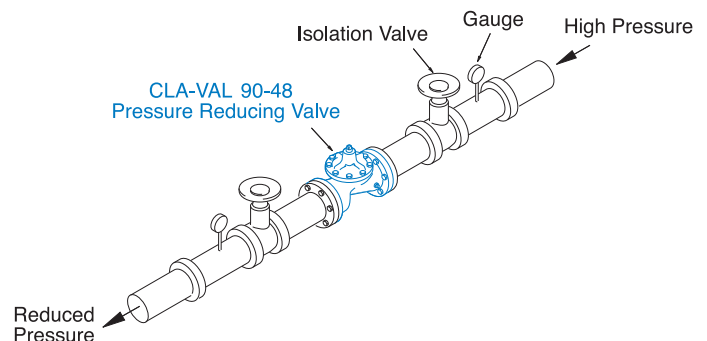

Model 90-48 (Uses 100-01 Hytrol Main Valve)

Pressure Ratings (Recommended Maximum Pressure - psi)

Valve Body & Cover		Pressure Class				
		Flanged		Grooved	Threaded	
Grade	Material	ANSI Standards*	150 Class	300 Class	300 Class	End‡ Details
ASTM A536	Ductile Iron	B16.42	250	400	400	400
ASTM A216-WCB	Cast Steel	B16.5	285	400	400	400
UNS 87850	Low Lead Bronze	B16.24	225	400	400	400

Note: * ANSI standards are for flange dimensions only.
 Flanged valves are available faced but not drilled.
 ‡ End Details machined to ANSI B2.1 specifications.
Valves for higher pressure are available; consult factory for details

Materials

Component	Standard Material Combinations		
Body & Cover	Ductile Iron	Cast Steel	Low Lead Bronze
Available Sizes	1" - 8"	1" - 8"	1" - 8"
	25 - 200 mm	25 - 200 mm	25 - 200 mm
Disc Retainer & Diaphragm Washer	Cast Iron	Cast Steel	Bronze
Trim: Disc Guide, Seat & Cover Bearing	Bronze is Standard Stainless Steel is Optional		
Disc	Buna-N® Rubber		
Diaphragm	Nylon Reinforced Buna-N® Rubber		
Stem, Nut & Spring	Stainless Steel		

For material options not listed, consult factory.
 Cla-Val manufactures valves in more than 50 different alloys.

Model 90-48 Dimensions (In Inches) - For larger sizes, consult Factory

Valve Size (Inches)	1	1¼	1½	2	2½	3	4	6	8
A Threaded	7.25	7.25	7.25	9.38	11.00	12.50	—	—	—
AA 150 ANSI	—	—	8.50	9.38	11.00	12.00	15.00	20.00	25.38
AAA 300 ANSI	—	—	9.00	10.00	11.62	13.25	15.62	21.00	26.38
AAAA Grooved End	—	—	8.50	9.00	11.00	12.50	15.00	20.00	25.38
B Diameter	5.62	5.62	5.62	6.62	8.00	9.12	11.50	15.75	20.00
C Maximum	5.50	5.50	5.50	6.50	7.56	8.19	10.62	13.38	16.00
CC Maximum Grooved End	—	—	4.75	5.75	6.88	7.25	9.31	12.12	14.62
D Threaded	3.25	3.25	3.25	4.75	5.50	6.25	—	—	—
DD 150 ANSI	—	—	4.00	4.75	5.50	6.00	7.50	10.00	12.69
DDD 300 ANSI	—	—	4.25	5.00	5.88	6.38	7.88	10.50	13.25
DDDD Grooved End	—	—	—	4.75	—	6.00	7.50	—	—
E	1.12	1.12	1.12	1.50	1.69	2.06	3.19	4.31	5.31
EE Grooved End	—	—	2.00	2.50	2.88	3.12	4.25	6.00	7.56
F 150 ANSI	—	—	2.50	3.00	3.50	3.75	4.50	5.50	6.75
FF 300 ANSI	—	—	3.06	3.25	3.75	4.13	5.00	6.25	7.50
G Threaded	1.88	1.88	1.88	3.25	4.00	4.50	—	—	—
GG 150 ANSI	—	—	4.00	3.25	4.00	4.00	5.00	6.00	8.00
GGG 300 ANSI	—	—	4.25	3.50	4.31	4.38	5.31	6.50	8.50
GGGG Grooved End	—	—	—	3.25	—	4.25	5.00	—	—
H NPT Body Tapping	0.375	0.375	0.375	0.375	0.50	0.50	0.75	0.75	1.00
J NPT Cover Center Plug	0.25	0.25	0.25	0.50	0.50	0.50	0.75	0.75	1.00
K NPT Cover Tapping	0.375	0.375	0.375	0.375	0.50	0.50	0.75	0.75	1.00
Stem Travel	0.40	0.40	0.40	0.60	0.70	0.80	1.10	1.70	2.30
Approx. Ship Weight (lbs)	15	15	15	35	50	70	140	285	500
Approx. X Pilot System	11	11	11	13	14	15	17	29	31
Approx. Y Pilot System	9	9	9	9	10	11	12	20	22
Approx. Z Pilot System	9	9	9	9	10	11	12	20	22

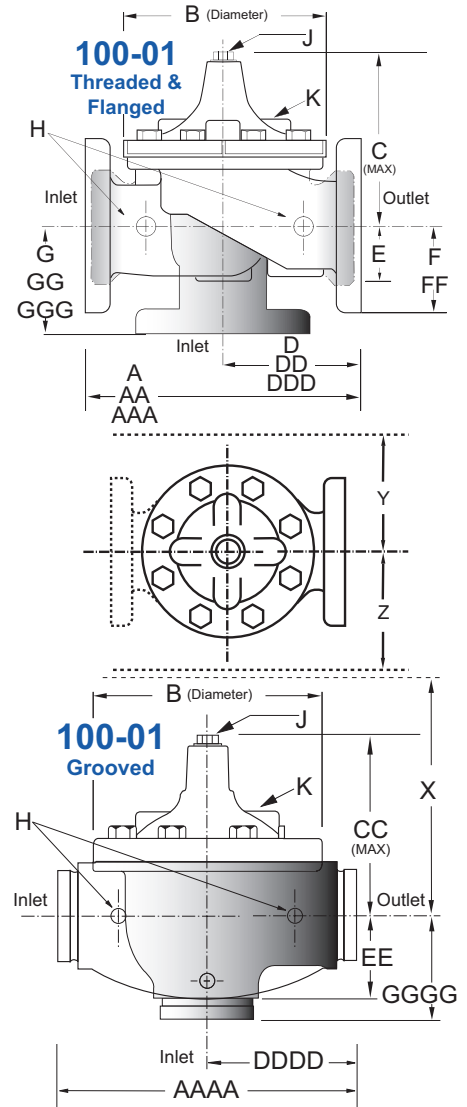

Model 90-48 Metric Dimensions (Uses 100-01 Hytrol Main Valve)

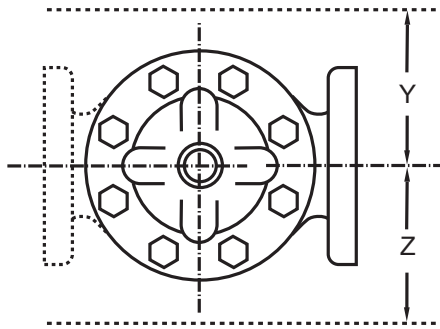
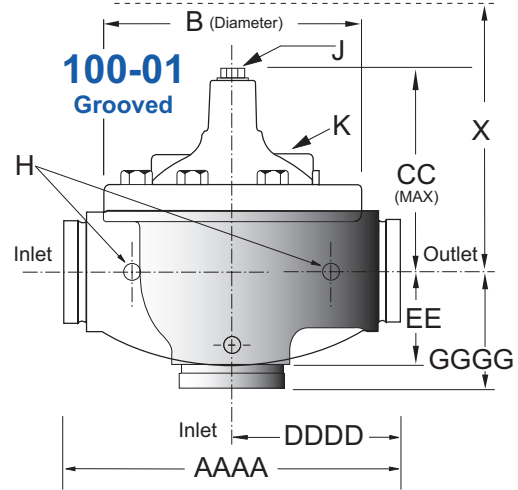
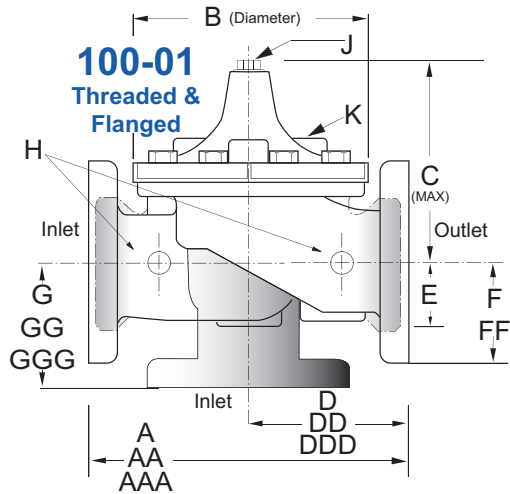

Model 90-48 Dimensions (mm) - For larger sizes, consult Factory

Valve Size (mm)	25	32	40	50	65	80	100	150	200
A Threaded	184	184	184	238	279	318	—	—	—
AA 150 ANSI	—	—	216	238	279	305	381	508	645
AAA 300 ANSI	—	—	229	254	295	337	397	533	670
AAAA Grooved End	—	—	216	228	279	318	381	508	645
B Diameter	143	143	143	168	203	232	292	400	508
C Maximum	140	140	140	165	192	208	270	340	406
CC Maximum Grooved End	—	—	120	146	175	184	236	308	371
D Threaded	83	83	83	121	140	159	—	—	—
DD 150 ANSI	—	—	102	121	140	152	191	254	322
DDD 300 ANSI	—	—	108	127	149	162	200	267	337
DDDD Grooved End	—	—	—	121	—	152	191	—	—
E	29	29	29	38	43	52	81	110	135
EE Grooved End	—	—	52	64	73	79	108	152	192
F 150 ANSI	—	—	64	76	89	95	114	140	171
FF 300 ANSI	—	—	78	83	95	105	127	159	191
G Threaded	48	48	48	83	102	114	—	—	—
GG 150 ANSI	—	—	102	83	102	102	127	152	203
GGG 300 ANSI	—	—	102	89	110	111	135	165	216
GGGG Grooved End	—	—	—	83	—	108	127	—	—
H NPT Body Tapping	0.375	0.375	0.375	0.375	0.50	0.50	0.75	0.75	1.00
J NPT Cover Center Plug	0.25	0.25	0.25	0.50	0.50	0.50	0.75	0.75	1.00
K NPT Cover Tapping	0.375	0.375	0.375	0.375	0.50	0.50	0.75	0.75	1.00
Stem Travel	10	10	10	15	18	20	28	43	58
Approx. Ship Weight (kgs)	7	7	7	16	23	32	64	129	227
Approx. X Pilot System	280	280	280	331	356	381	432	737	788
Approx. Y Pilot System	229	229	229	229	254	280	305	508	559
Approx. Z Pilot System	229	229	229	229	254	280	305	508	559

Valve Selection Guide

90-48 Valve Selection	Inches	1	1½	1½	2	2½	3	4	6	8
	mm	25	32	40	50	65	80	100	150	200
Main Valve 100-01	Pattern	G, A	G, A	G, A	G, A	G, A	G, A	G, A	G, A	G, A
	End Detail	T	T	T, F, Gr*	T, F, Gr	T, F, Gr*	T, F, Gr	F, Gr	F, Gr*	F, Gr*
Suggested Flow (gpm)	Maximum	55	93	125	210	300	460	800	1800	3100
	Maximum Intermittent	68	120	160	260	370	580	990	2250	3900
	Minimum	1	1	1	1	1	1	1	1	1
Suggested Flow (Liters/Sec)	Maximum	3.5	6	8	13	19	29	50	113	195
	Maximum Intermittent	4.3	7.6	10	16	23	37	62	142	246
	Minimum	.06	.06	.06	.06	.06	.06	.06	.06	.06

100-01 Pattern: Globe (G), Angle (A), **End Connections:** Threaded (T), Grooved (GR), Flanged (F) Indicate Available Sizes
100-01 Series is the full internal port Hytrol. For Lower Flows Consult Factory

*Globe Grooved Only

Pilot System Specifications



CRD-L



CRD

Adjustment Ranges CRD

2 to 30 psi
 15 to 75 psi
 20 to 105 psi
 30 to 300 psi*

CRD-L (Bypass)

15 to 65 psi
 25 to 100 psi
 80 to 150 psi

*Supplied unless otherwise specified
 Other ranges available, please consult factory.

Temperature Range

Water: to 180° F / 82° C

Consult factory for hot water applications.

Materials

Standard Pilot System Materials

Pilot Control: Low Lead Bronze
 Trim: Stainless Steel Type 303
 Rubber: Buna-N® Synthetic Rubber

Optional Pilot System Materials

Pilot Systems are available with optional Aluminum, Stainless Steel or Monel materials.

When Ordering, Specify:

1. Catalog No. 90-48
2. Valve Size
3. Pattern - Globe or Angle
4. Pressure Class
5. Threaded, Flanged or Grooved
6. Trim Material
7. Adjustment Range
8. Desired Options
9. When Vertically Installed

See Cla-Val Model # 690-48 for applications requiring a reduced port valve.

Valve Options

X141 Pressure Gauge



X101AR Valve Position Indicator with Air Release



X101 Valve Position Indicator



X144 e-FlowMeter



X43H Strainer



Stainless Steel Pilot