

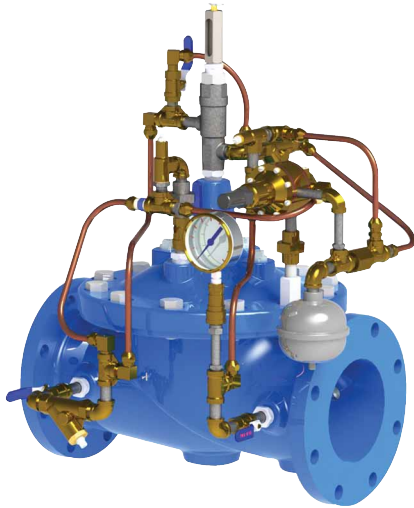

— MODEL — **98-06**

# Hydraulic Pressure Management/ Water Savings Valve with Dual Setpoints



- Simple means to achieve measurable water savings
- Helps reduce consumption
- 100% hydraulic control
- Two adjustable downstream set points for high and low pressure
- Smooth transition between set point pressures
- Simple set-up
- Retrofits to existing valve without removal from pipeline

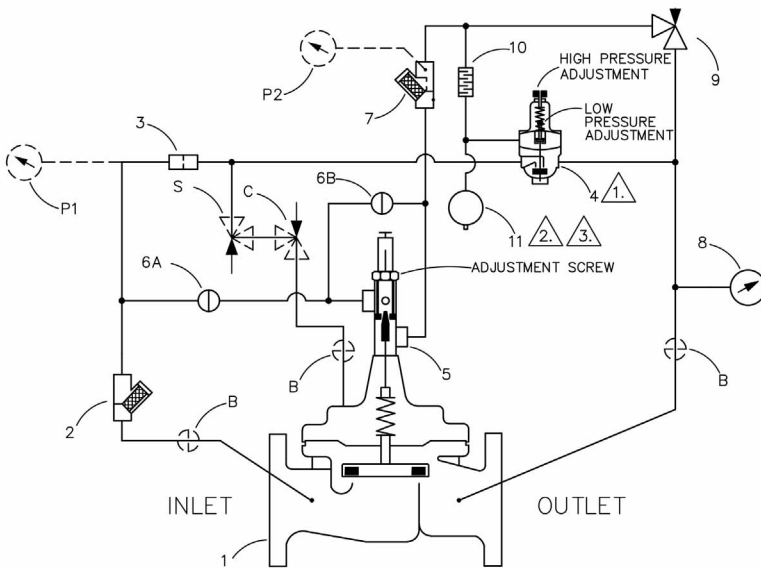

## Schematic Diagram

Item	Description
1	100-01 Hytrol Main Valve
2	X43 "Y" Strainer
3	X58C Restriction Assembly
4	CPM-A Pressure Management Control
5	X78-4 Stem Assembly + X101 Valve Position Indicator Assembly
6	CK2 Isolation Valve
7	X44A Strainer Orifice Assembly
8	X141 Gage Assembly
9	CV Speed Control
10	X58E Restriction Assembly
11	Accumulator (Air Charged)

## Optional Features

Item	Description
B	CK2 Isolation Valve
C	CV Flow Control (Closing)
P	X141 Gage Assembly
S	CV Flow Control (Opening)

## Typical Performance

A dual system pressure with reduced system pressure during low demand periods is illustrated in the chart. At low flows, a minimum pressure is maintained and as flow increases to the switch point, delivery pressure increases to the maximum pressure set point for switch. The point between low pressure and high pressure setpoints is adjustable to fine-tune the valve to system requirements. The "water saving zone" below maximum pressure line represents valve effectiveness in reducing water losses and frequency of pipe breaks in a system.

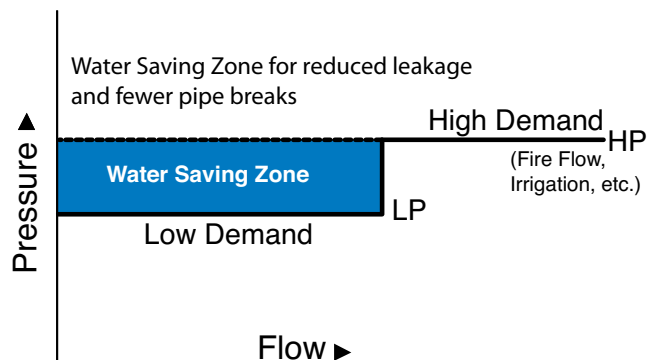

**Model 98-06** (Uses 100-01 Hytrol Main Valve)

**Pressure Ratings** (Recommended Maximum Pressure - psi)

Valve Body & Cover		Pressure Class				
		Flanged			Grooved	Threaded
Grade	Material	ANSI Standards*	150 Class	300 Class	300 Class	End‡ Details
ASTM A536	Ductile Iron	B16.42	250	400	400	400
ASTM A216-WCB	Cast Steel	B16.5	285	400	400	400
UNS 87850	Bronze	B16.24	225	400	400	400

Note: \* ANSI standards are for flange dimensions only.  
 Flanged valves are available faced but not drilled.  
 ‡ End Details machined to ANSI B2.1 specifications.  
**Valves for higher pressure are available; consult factory for details**

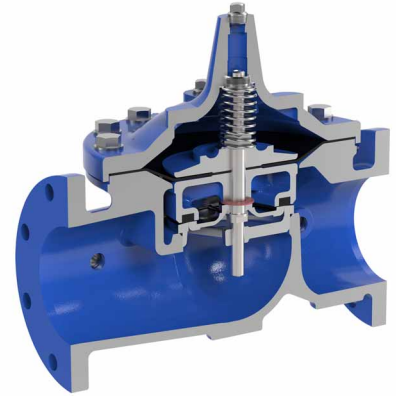

**Materials**

Component	Standard Material Combinations		
Body & Cover	Ductile Iron	Cast Steel	Bronze
Available Sizes	2" - 10" 50 - 250mm	2" - 10" 50 - 250mm	2" - 10" 50 - 250mm
Disc Retainer & Diaphragm Washer	Cast Iron	Cast Steel	Bronze
Trim: Disc Guide, Seat & Cover Bearing	Bronze is Standard Stainless Steel is Optional		
Disc	Buna-N® Rubber		
Diaphragm	Nylon Reinforced Buna-N® Rubber		
Stem, Nut & Spring	Stainless Steel		

For material options not listed, consult factory.  
 Cla-Val manufactures valves in more than 50 different alloys.

**Model 100-01 Full Port Hytrol Main Valve**



**Model 98-06 Dimensions** (In Inches)

Valve Size (Inches)	2	2½	3	4	6	8	10
A Threaded	9.38	11.00	12.50	—	—	—	—
AA 150 ANSI	9.38	11.00	12.00	15.00	20.00	25.38	29.75
AAA 300 ANSI	10.00	11.62	13.25	15.62	21.00	26.38	31.12
AAAA Grooved End	9.00	11.00	12.50	15.00	20.00	25.38	—
B Diameter	6.62	8.00	9.12	11.50	15.75	20.00	23.62
C Maximum	6.50	7.56	8.19	10.62	13.38	16.00	17.12
CC Maximum Grooved End	5.75	6.88	7.25	9.31	12.12	14.62	—
D Threaded	4.75	5.50	6.25	—	—	—	—
DD 150 ANSI	4.75	5.50	6.00	7.50	10.00	12.69	14.88
DDD 300 ANSI	5.00	5.88	6.38	7.88	10.50	13.25	15.56
DDDD Grooved End	4.75	—	6.00	7.50	—	—	—
E	1.50	1.69	2.06	3.19	4.31	5.31	9.25
EE Grooved End	2.50	2.88	3.12	4.25	6.00	7.56	—
F 150 ANSI	3.00	3.50	3.75	4.50	5.50	6.75	8.00
FF 300 ANSI	3.25	3.75	4.13	5.00	6.25	7.50	8.75
G Threaded	3.25	4.00	4.50	—	—	—	—
GG 150 ANSI	3.25	4.00	4.00	5.00	6.00	8.00	8.62
GGG 300 ANSI	3.50	4.31	4.38	5.31	6.50	8.50	9.31
GGGG Grooved End	3.25	—	4.25	5.00	—	—	—
H NPT Body Tapping	0.375	0.50	0.50	0.75	0.75	1.00	1.00
J NPT Cover Center Plug	0.50	0.50	0.50	0.75	0.75	1.00	1.00
K NPT Cover Tapping	0.375	0.50	0.50	0.75	0.75	1.00	1.00
Stem Travel	0.60	0.70	0.80	1.10	1.70	2.30	2.80
Approx. Ship Weight (lbs)	35	50	70	140	285	500	780
Approx. X Pilot System	13	14	15	17	29	31	33
Approx. Y Pilot System	9	10	11	12	20	2	—
Approx. Z Pilot System	9	10	11	12	20	2	—

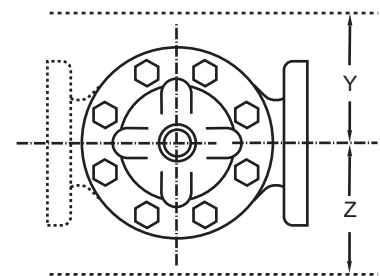
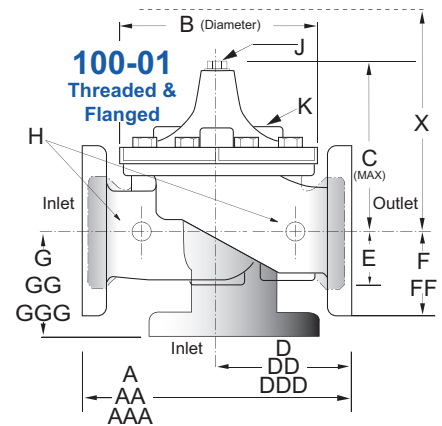

## Model 98-06 Metric Dimensions (Uses 100-01 Hytrol Main Valve)

### Dimensions (In mm)

Valve Size (mm)	50	65	80	100	150	200	250
A Threaded	238	279	318	—	—	—	—
AA 150 ANSI	238	279	305	381	508	645	756
AAA 300 ANSI	254	295	337	397	533	670	790
AAAA Grooved End	228	279	318	381	508	645	—
B Diameter	168	203	232	292	400	508	600
C Maximum	165	192	208	270	340	406	435
CC Maximum Grooved End	146	175	184	236	308	371	—
D Threaded	121	140	159	—	—	—	—
DD 150 ANSI	121	140	152	191	254	322	378
DDD 300 ANSI	127	149	162	200	267	337	395
DDDD Grooved End	121	—	152	191	—	—	—
E	38	43	52	81	110	135	235
EE Grooved End	64	73	79	108	152	192	—
F 150 ANSI	76	89	95	114	140	171	203
FF 300 ANSI	83	95	105	127	159	191	222
G Threaded	83	102	114	—	—	—	—
GG 150 ANSI	83	102	102	127	152	203	219
GGG 300 ANSI	89	110	111	135	165	216	236
GGGG Grooved End	83	—	108	127	—	—	—
H NPT Body Tapping	0.375	0.50	0.50	0.75	0.75	1.00	1.00
J NPT Cover Center Plug	0.50	0.50	0.50	0.75	0.75	1.00	1.00
K NPT Cover Tapping	0.375	0.50	0.50	0.75	0.75	1.00	1.00
Stem Travel	15	18	20	28	43	58	71
Approx. Ship Weight (kgs)	16	23	32	64	129	227	354
Approx. X Pilot System	331	356	381	432	737	788	839
Approx. Y Pilot System	229	254	280	305	508	559	610
Approx. Z Pilot System	229	254	280	305	508	559	610

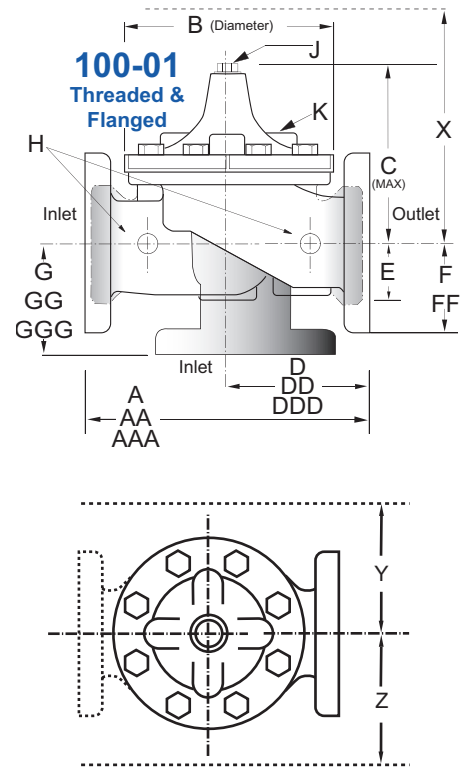

### How It Works

The Cla-Val Model 98-06 Water Saving Valve is a pressure reducing valve that uses two downstream set points to achieve optimum system pressure; i.e. the capability delivering only the pressure that is needed to meet current demand.

A high pressure set point is selected for high flow demand and a low pressure set point is selected for low demand. This dual set point arrangement allows for reduction in water consumption as well as unintentional water loss by keeping system piping from being over-pressurized during periods of low demand. It does this without inhibiting adequate pressure during high or fire demand. The design is 100% hydraulic and, in addition, to the dual pressure set points, the transition point at which the pressure changes based on the flow is also adjustable. The patented design of the valve allows for smooth transition from one set point to the other, providing optimum performance and measurable water savings by reducing consumption, minimizing leaks and lessening the potential for pipe breaks.

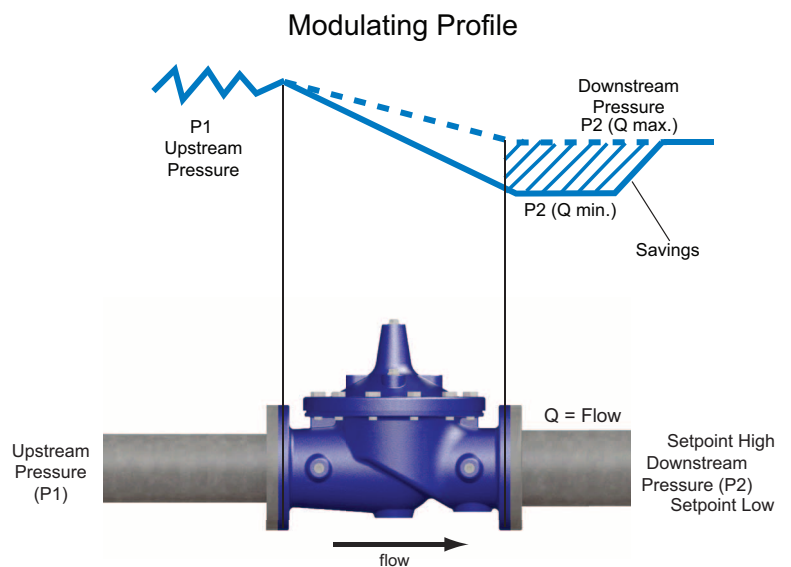

98-06 Valve Selection	100-01 Pattern: Globe (G), Angle (A), End Connections: Threaded (T), Grooved (GR), Flanged (F) Indicate Available Sizes							
	Inches	2	2½	3	4	6	8	10
	mm	50	65	80	100	150	200	250
Main Valve 100-01	Pattern	G, A	G, A	G, A	G, A	G, A	G, A	G, A
	End Detail	T, F, Gr	T, F, Gr*	T, F, Gr	F, Gr	F, Gr*	F, Gr*	F
Suggested Flow (gpm)	Maximum	210	300	460	800	1800	3100	4900
	Maximum Intermittent	260	370	580	990	2250	3900	6150
	Minimum	1	2	2	4	10	15	35
Suggested Flow (Liters/Sec)	Maximum	13	19	29	50	113	195	309
	Maximum Intermittent	16	23	37	62	142	246	387
	Minimum	.06	.09	0.13	0.25	0.63	0.95	2.2

100-01 Series is the full internal port Hytrol.

For Lower Flows Consult Factory

\*Globe Grooved Only

Many factors should be considered in sizing pressure reducing valves including inlet pressure, outlet pressure and flow rates. For sizing questions or cavitation analysis, consult Cla-Val with system details.

Not Recommended for Dead-end Service

## Pilot System Specifications

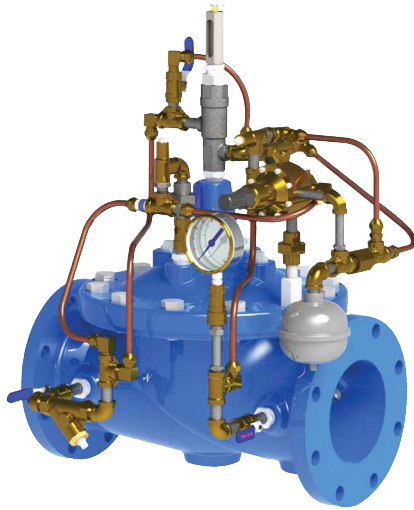

### Temperature Range

Water: to 180°F

Consult factory for hot water applications.

### Materials

#### Standard Pilot System Materials

Pilot Control: Stainless Steel & Low Lead Bronze

Trim: Stainless Steel Type 303

Rubber: Buna-N® Synthetic Rubber

**Go to [www.cla-val.com](http://www.cla-val.com) for  
Purchase Specification**

### When Ordering, Specify:

1. Catalog No. 98-06
2. Valve Size
3. Pattern - Globe or Angle
4. Pressure Class
5. Threaded or Flanged
6. Trim Material
7. Desired Options
8. When Vertically Installed



E-98-06 (R-08/2024)

## CLA-VAL

1701 Placentia Avenue • Costa Mesa, CA 92627

800-942-6326 • Web Site: [www.cla-val.com](http://www.cla-val.com) • E-mail: [info@cla-val.com](mailto:info@cla-val.com)

**CLA-VAL CANADA**  
4687 Christie Drive  
Beamsville, Ontario  
Canada L0R 1B4  
Phone: 905-563-4963  
[www.cla-val.com](http://www.cla-val.com)  
E-mail [sales@cla-val.ca](mailto:sales@cla-val.ca)

**CLA-VAL EUROPE**  
Chemin des Mésanges 1  
CH-1032 Romanel/  
Lausanne, Switzerland  
Phone: 41-21-643-15-55  
[www.cla-val.ch](http://www.cla-val.ch)  
E-mail: [info@cla-val.ch](mailto:info@cla-val.ch)

**CLA-VAL UK**  
Dainton House, Goods Station Road  
Tunbridge Wells  
Kent TN11 2 DH England  
Phone: 44-1892-514-400  
[www.cla-val.ch](http://www.cla-val.ch)  
E-mail: [info@cla-val.co.uk](mailto:info@cla-val.co.uk)

**CLA-VAL FRANCE**  
Porte du Grand Lyon 1  
ZAC du Champ du Pérrier  
France - 01700 Neyron  
Phone: 33-4-72-25-92-93  
[www.cla-val.ch](http://www.cla-val.ch)  
E-mail: [info@cla-val.ch](mailto:info@cla-val.ch)

**CLA-VAL ASIA PACIFIC**  
45 Kennaway Road  
Woolston, Christchurch, 8023  
New Zealand  
Phone: 64-39644860  
[www.cla-valpacific.com](http://www.cla-valpacific.com)  
E-mail: [info@cla-valpacific.com](mailto:info@cla-valpacific.com)

© COPYRIGHT CLA-VAL Printed in USA Specifications subject to change without notice.

visit [www.cla-val-latinamerica.com](http://www.cla-val-latinamerica.com) for Spanish literature