

---

# CLA-VAL

**AUTOMATIC CONTROL VALVES**

---

**95-01/695-01**

Place this manual with personnel responsible  
for maintenance of this valve

---

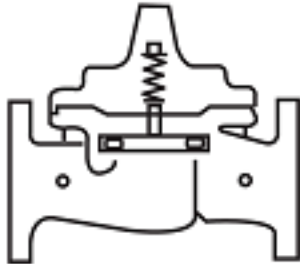

## *Installation*

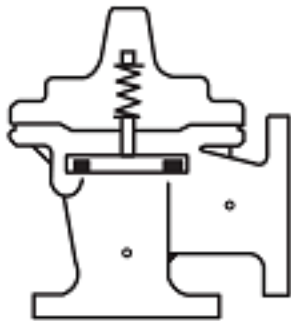

## *Operation*

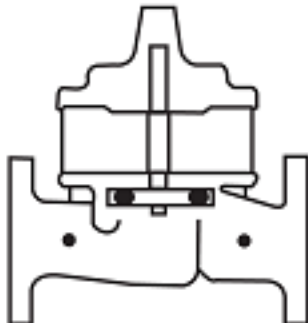

## *Maintenance*





**CLA-VAL CO.**

NEWPORT BEACH, CALIFORNIA

CATALOG NO.

95-01/695-01

DRAWING NO.

205626

REV.

—

TYPE OF VALVE AND MAIN FEATURES

RATIO REDUCTION CONTROL VALVE

DESIGN

DRAWN

PC

5-30-2006

CHK'D

VL

6-2-06

APVD

CH

6-2-06

----- NOT FURNISHED BY CLA-VAL CO.

----- OPTIONAL FEATURES

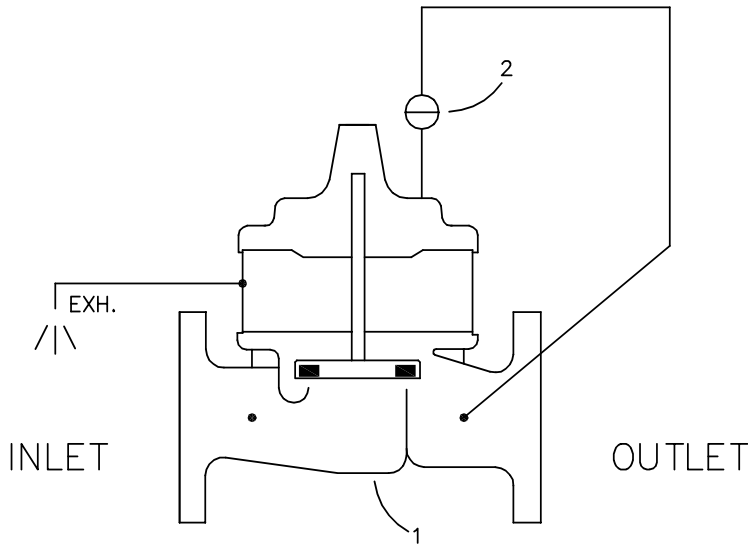

CAD REVISION RECORD - DO NOT REVISE MANUALLY

DATE  
5-31-2006

BY  
PC

DESCRIPTION

RELEASED FOR PRODUCTION (NED 50789)

LTR  
—

ITEM NO.	BASIC COMPONENTS	QTY
1	100-02 POWERROL (95-01) MAIN VALVE	1
	100-21 POWERROL (695-01) MAIN VALVE	
2	CK2 ISOLATION VALVE	1

OPTIONAL FEATURE SUFFIX      ADDED TO CATALOG NUMBER

"THIS DRAWING IS THE PROPERTY OF CLA-VAL CO. AND SAME AND COPIES MADE THEREOF, IF ANY, SHALL BE RETURNED TO IT UPON DEMAND. DELIVERY AND DISCLOSURE HEREOF ARE SOLELY UPON CONDITION THAT THE SAME SHALL NOT BE USED, COPIED OR REPRODUCED, NOR SHALL THE SUBJECT HEREOF BE DISCLOSED IN ANY MANNER TO ANYONE FOR ANY PURPOSE, EXCEPT AS HEREIN AUTHORIZED, WITHOUT PRIOR WRITTEN APPROVAL OF CLA-VAL CO. THIS DRAWING IS SUBMITTED CONFIDENTIALLY AND MAY NOT BE USED IN THE MANUFACTURE OF ANY MATERIAL OR PRODUCT OTHER THAN SUCH MATERIALS AND PRODUCTS FURNISHED TO CLA-VAL CO. WHETHER OR NOT THE EQUIPMENT OR INFORMATION SHOWN HEREON IS PATENTED OR OTHERWISE PROTECTED, FULL TITLE AND COPYRIGHTS, IF ANY, IN AND TO THIS DRAWING AND/OR INFORMATION DELIVERED OR SUBMITTED ARE FULLY RESERVED CLA-VAL CO."



**CLA-VAL CO.**

NEWPORT BEACH, CALIFORNIA

CATALOG NO.

95-01/695-01

DRAWING NO.

205626

REV.

—

TYPE OF VALVE AND MAIN FEATURES

RATIO REDUCTION CONTROL VALVE

DESIGN

DRAWN

PC

5-30-2006

CHK'D

VL

6-2-06

APVD

CH

6-2-06

OPERATING DATA

I. RATIO PRESSURE CONTROL FEATURE:

WHEN DOWNSTREAM PRESSURE IS APPLIED TO THE MAIN VALVE COVER AND IS RELIEVED FROM THE POWERUNIT CHAMBER TO ATMOSPHERE, THE MAIN VALVE CLOSES. WHEN UPSTREAM PRESSURE IS APPLIED BELOW THE SEAT AREA OF THE MAIN VALVE AND PRESSURE IS RELIEVED FROM THE MAIN VALVE COVER TO OUTLET, THE MAIN VALVE OPENS. THIS CAUSES THE MAIN VALVE TO MODULATE (OPENS AND CLOSES) MAINTAINING A RELATIVELY CONSTANT RATIO PRESSURE.

II. CHECK LIST FOR PROPER OPERATION:

- ( ) SYSTEM VALVES OPEN UPSTREAM AND DOWNSTREAM.
- ( ) AIR REMOVED FROM THE MAIN VALVE COVER AND PILOT SYSTEM AT ALL HIGH POINTS.
- ( ) CK2 COCK (2) OPEN DURING NORMAL OPERATION.

CAD REVISION RECORD - DO NOT REVISE MANUALLY

DESCRIPTION

DATE

BY

LTR

SEE SHEET 1.



## Recommended Inspections

Cla-Val recommends that an inspection be performed on our products annually. The inspection should include both a visual and functional test of the main valve/component and the pilot system. The inspection ensures that no damage or premature wear occurred due to velocity, pressure, or foreign matter within the fluid that may have exceeded the valve's design. Please consult the maintenance manual for specific information on the model. Manuals are available for download at [Cla-Val.com](http://Cla-Val.com), as well as contact information for a company representative.

Accurate record-keeping is a best practice for any preventative maintenance program, and Cla-Val strongly recommends this action through an asset management program. Cla-Val provides a free asset management tool, Link2Valves [Link2Valves - Cla-Val \(cla-val.com\)](http://Link2Valves - Cla-Val (cla-val.com)), to assist in preventative maintenance record-keeping and scheduling.



— MODEL — **100-02**  
(Full Internal Port)

# Powertrol Valve

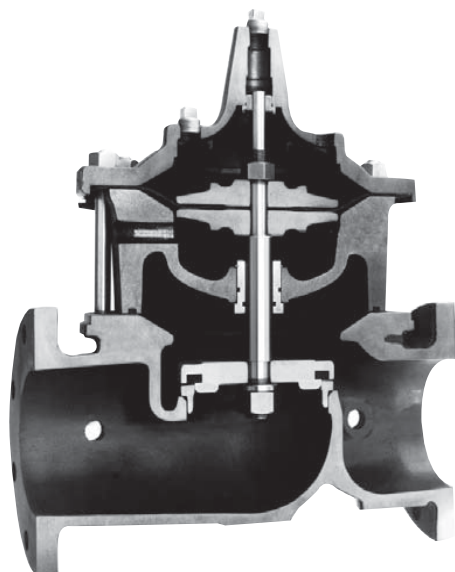

## DESCRIPTION

This manual contains information for installation, operation and maintenance of the Cla-Val Co. 100-02 Powertrol, an automatic valve designed for use where independent operating pressure is desired, or when line fluid is unsuitable as an operating medium.

This valve is a hydraulically operated, diaphragm type, globe or angle pattern valve. It is single seated and incorporates into its design two operating chambers sealed from one another by a flexible synthetic rubber diaphragm. Pressure applied to the upper chamber closes the valve; when applied to the lower chamber, it opens the valve.

With proper pilot controls, the valve can be held in any intermediate position between fully open and tightly closed.

## INSTALLATION

1. Allow sufficient room around the valve assembly to make adjustments and for disassembly.

**NOTE: BEFORE THE VALVE IS INSTALLED, PIPE LINES SHOULD BE FLUSHED OF ALL CHIPS, SCALE AND FOREIGN MATTER.**

2. It is recommended that gate or block valves be installed on both the upstream and downstream sides of the 100-02 to facilitate isolating the valve for preventative maintenance.
3. Place the valve in the line with flow through the valve in the direction indicated on the inlet name plate or by flow arrows.
4. Cla-Val Powertrol Valves operate with maximum efficiency when mounted in horizontal piping with cover "UP," however, other positions are acceptable. Due to the size and weight of the cover and internal assembly of 4" and larger valves, installation with the cover "UP" is advisable. This makes periodic inspection of internal parts readily accessible.
5. When a pilot control system is installed on the Powertrol Valve, use care to prevent damage. If it is necessary to remove fittings or components, be sure they are kept clean and replaced in the exact order of removal.
6. After the valve is installed and the system is first pressurized, vent air from the cover chamber and tubing by loosening fit "sings" at all high points.

## TROUBLE SHOOTING

The following trouble shooting information deals strictly with the Powertrol Valve; however some "impossible causes" will refer to components that may exist in the variety of control systems available for the valve. All trouble shooting is possible without removing the valve from the line.

**CAUTION:** Extreme care should be taken when servicing the valve. Gate or line block valves must be closed upstream and downstream of the valve before starting disassembly. When there are no block or gate valves to isolate the Powertrol Valve it should be realized that the valve cannot be serviced under pressure. Steps must be taken to remedy this situation before proceeding.

## Principle of Operation

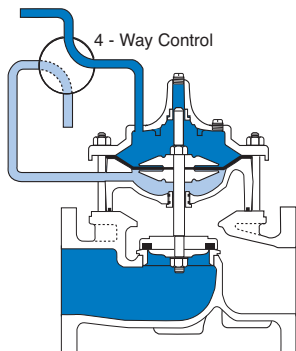

**Full Open Operation**

When operating pressure below the diaphragm is applied and operating pressure is relieved from the cover chamber, the valve is held open, allowing full flow.

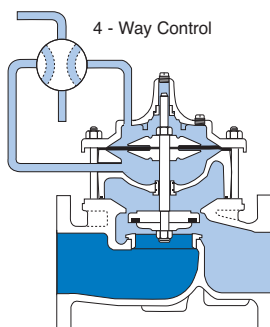

**Tight Closing Operation**

When pressure below the diaphragm is relieved and operating pressure is applied to the cover chamber, the valve closes drip-tight.

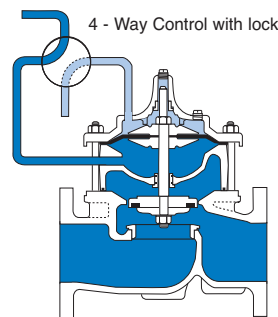

**Modulating Action**

The valve holds any intermediate position when operating pressure is equal above and below the diaphragm. A Cla-Val four-way pilot control with "lock" position can maintain this balance by stopping flow in the pilot control system.

SYMPTOM	*POSSIBLE CAUSE	TEST PROCEDURE	REMEDY
Valve fails to close.	Stem stuck in open position.	Vent power unit chamber. Apply pressure to cover chamber. Valve should close.	Disassemble, examine all internal parts for cause of the sticking condition and clean off scale deposits.
	Worn diaphragm or loose upper stem nut	Apply pressure in power unit chamber and vent cover. Continuous flow from cover indicates this trouble.	Disassemble and replace diaphragm or tighten the valve stem nut.
	Foreign object on valve seat.	Valve opens okay but only closes part way.	Try operating valve a few times. This might dislodge the object. If this fails, disassemble and remove the obstruction.
	Pressure not being released from power unit chamber.	Make sure pressure is being released by opening a fitting into the chamber. If valve then closes refer to remedy.	Check control system. Tube line or nipple might be plugged up.
	Operating pressure not getting into valve cover.	Use pressure gauge or loosen cover plug to check for pressure.	Clean tubing or pipe fittings into cover chamber. Open CK2 Isolation Valve in control lines.
	Insufficient line pressure.	Check line pressure.	Establish line pressure.
Valve fails to open.	Stem stuck in closed or semi-open position.	Vent cover. Apply pressure to power unit chamber.	Disassemble, examine all internal parts for cause of the sticking problem, and clean off scale deposits.
	Worn diaphragm or loose upper stem nut.	Apply pressure in power unit chamber and vent cover. Continuous flow from cover indicates this problem.	Disassemble and replace diaphragm or tighten valve stem nut.
	Foreign object on top of disc retainer	Valve closed okay but won't open all the way.	Try operating valve a few times. This might dislodge the object. If this fails disassemble and remove the obstruction.
	Pressure not being released from cover chamber.	Open a fitting or remove a plug from cover chamber if cover chamber vents and valve opens, see remedy.	Check control system. Check lines or pipe fittings. Clean out any plugged lines.
	Operating pressure not applied into power unit chamber.	Loosen a fitting in this chamber to check for pressure at this point.	Clean tubing or pipe fittings into power unit chamber.
Valve closes but leakage occurs.	Worn disc or seat.	The best procedure here is to disassemble the valve and inspect these parts.	Replace worn parts.
O-Ring failure	Mineral deposits on stem cause abrasion on ring.	Remove pressure from both cover and power unit chambers and apply line pressure to valve. Open line from power unit chamber and observe continuous flow.	Disassemble and replace O-ring.

\*Assuming control system is functioning properly.

## FREEDOM OF MOVEMENT

The following procedures can be used to determine if the valve opens and closes fully. During this test the diaphragm can be checked for damage.

1. The Powerrol Valve will have a control to open and close the valve. Position the control so that pressure is applied to the cover chamber (above the valve diaphragm). This will close the Powerrol Valve. Check the drain from the control that discharges to atmosphere.

Once the liquid from the lower diaphragm chamber is drained the discharge should stop. If the discharge continues after the normal time it takes to drain then the diaphragm is damaged, or the stem nut is loose, or the stem o-ring is leaking. If the discharge is continuous from both chambers then there is a possibility that the diaphragm or the pilot control is damaged.

If the valve is equipped with a "Dry Drain" (control drain piped to downstream end of the valve) then same procedure is followed except the CK2 Shutoff Cock on the downstream end of the valve must be closed and the drain line disconnected and drained to atmosphere. It can then be checked as above.

Measurement of the vertical travel of the stem (diaphragm assembly) will make it possible to determine if the travel, or stroke is restricted. The following chart provides this measurement. It is necessary to have either the X101 Valve Position Indicator or X105 Limit Switch Assembly installed on the valve to visually check the travel.

Mark the position of the stem on the X101 or X105 when the valve is closed. Reposition the control so that pressure is applied below the diaphragm and the cover chamber is drained. Determine the extent of the stem travel. Check this movement with the stem travel chart. If the stroke is different than listed (5% to 10%) then there is good reason to believe something is mechanically restricting the stroke of the valve at one end of its travel. If it is determined that flow does not stop through the valve when in the indicated "closed" position, the obstruction probably is between the disc and the seat, or in the power unit chamber below the diaphragm. If the flow stops, the obstruction is likely in the cover chamber above the diaphragm or possibly above the disc retainer. Refer to the sectional view under Principle of Operation.

If operation of the valve a few times does not dislodge the foreign object obstructing the diaphragm assembly (stem) movement then the valve must be disassembled and the problem located and corrected. See disassembly instructions.

### STEM TRAVEL

(Fully open to fully closed)

INCHES	VALVE SIZE		INCHES	MM
	MM	VALVE SIZE		
1	25	0.3	8	
1 1/4	32	0.4	10	
1 1/2	40	0.4	10	
2	50	0.6	15	
2 1/2	65	0.7	18	
3	80	0.8	20	
4	100	1.1	23	
6	150	1.7	43	
8	200	2.3	58	
10	250	2.8	71	
12	300	3.4	86	
14	350	3.9	99	
16	400	4.5	114	

## MAINTENANCE

### Preventative Maintenance

The Cla-Val Co Powertrol Valves require no lubrication or packing and a minimum of maintenance. However, a periodic inspection schedule should be established to determine how the fluid velocity as well as the substances occurring in natural waters are affecting the valve. These substances can be dissolved minerals, colloidal and suspended particles. Effect of these actions or substances must be determined by inspection.

## DISASSEMBLY

1. First mark the side of the valve cover, power unit body and valve body so that reassembly of these parts will be exactly as removed.

2. The Powertrol Valve inspection or maintenance can be accomplished without removal of the valve body from the line. Shut off pressure to the valve, both inlet, outlet and independent operating pressure when used.

**WARNING:** Maintenance personnel can be injured and equipment and property damaged if disassembly is attempted with pressure in the system.

3. After pressure has been released from the valve control system and operating chambers of the valve, remove the controls and tubing. Obtain a schematic of the assembly or note and sketch position of tubing and controls for reassembly. Replacing tubing into the control ports exactly as removed is necessary. Failure to reassemble properly will cause the valve to malfunction and possibly cause serious damage.

4. Remove cover nuts and cover. If the valve has been in service for any length of time, chances are the cover will have to be loosened by driving upward along the edge of the cover with a dull cold chisel. See Figure 1.

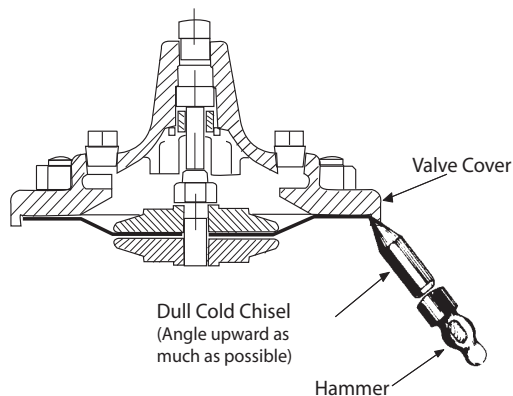

When block and tackle or a power hoist is to be used to lift the valve cover insert a proper size eye bolt in place of the center cover plug. Pull cover straight up to keep from damaging the power unit stem bearing and upper stem.

On valves 1" and larger remove the power unit retaining nuts. The power unit body can now be lifted from the valve body. The stem with diaphragm assembly and disc retainer assembly will be removed with the power unit body.

**CAUTION:** During service performed on the stem assembly, the stem surfaces must not be damaged. If a vice or other holding device is used to grip the stem, soft jaws of brass or copper must be used to protect the precision ground surface of the stainless steel stem. If the stem is marred no amount of careful dressing can restore the stem to its original condition.

6. Inspect the threads on the stem. Mineral deposits that prevent the nuts from turning must be cleaned from the threads. A 5C.h solution of muriatic acid will soften mineral or scale deposits to assist in removal of nuts and general cleaning of parts. Flush the parts thoroughly with water immediately after cleaning.

Care must always be exercised when handling acid. Read the warning label on the acid container to be sure of correct method of use and disposal after use.

7. Remove the upper stem nut, upper diaphragm washer, diaphragm and lower diaphragm washer. The stem with the disc retainer assembly can now be removed from the power unit body.

8. Hold the stem in a vice with soft jaws and remove the lower stem nut. Remove the lock washer, disc retainer, space washer(s) and disc. Refer to the sectional view of the valve size being serviced. This will assist in the disassembly procedure outlined above. The reassembly instructions outlining proper procedure and quantity of space washers. This is especially important if the disc is replaced.

### Inspection of Parts

1. Returning to the valve body in the line, the seat should now be inspected for damage. If the seat requires removal use the following tools. Seats in valve sizes 1/2" and 3/4" can be removed with a hex socket wrench. Seats in valve sizes 1" through 6" should be removed with accessory X-109 Seat Removing Tool available from the factory. Seats in valve sizes 3" through 16" may be removed with a screw driver. If upon removal of the screws the seat cannot be lifted out, it will be necessary to use a hard rubber mallet and tap the seat loose.

2. Any buildup of mineral or scale should be cleaned from the valve body at this time. Inspection of the cover and power unit body surfaces that contact the diaphragm is important. Clean and smooth, with wet or dry emery paper, any roughness that could damage the diaphragm. Inspect and recondition the surface on the upper and lower diaphragm washers. The perimeter of the diaphragm washers is the most likely area to cause diaphragm wear if the surface is not smooth. Take extra care to make this a smooth finish.

3. Inspect the power unit body bearing insert o-ring that is in contact with the stem. If it is worn, nicked or cut, replace it.

4. Inspect the diaphragm for cracks or chafing. Replace the diaphragm if damaged.

Inspect the disc and replace if the surface is damaged or worn. If a new disc is not available, the existing disc can be turned over, exposing the unused surface for contact with the seat.

6. The disc guide should be checked and cleaned of scales and mineral deposits. Due to the close tolerance between the outer periphery of the disc guide and the inner area of the valve seat, no scale or mineral deposits should be overlooked.

## REASSEMBLY

To reassemble, reverse the order of disassembly.

1. If the disc has been removed, it is important that correct pressure be on the disc from the disc guide when the lower stem nut is tight. Use sufficient spacer washers to obtain slight pressure (by visual indentation) on the disc. This applies to 1" through 16" valves. Refer to seat and disc detail drawings for location of spacer washers for various valve sizes.

**Note:** New discs will usually require a different number of spacer washers to obtain the right amount of 'grip (slight indentation) on the disc.

1. If the disc has been removed, it is important that correct pressure be on the disc from the disc guide when the lower stem nut is tight. Use sufficient spacer washers to obtain slight pressure (by visual indentation) on the disc. Indentation should be slight and no looseness evident. This adjustment applies to 1" through 16". Refer to seat and disc detail drawings for location of spacer washers for various valve sizes.

NOTE: New discs will usually require a different number of spacer washers to obtain the right amount of "grip" on the disc.

2. The stem, with the disc assembly, can now be inserted through the power unit body. Note sectional view for correct position of the power unit body and stem assembly

3. Install on the cover end of the stem the lower diaphragm washer, the diaphragm, the upper diaphragm washer, then screw on the upper stem nut.

4. Tighten the upper stem nut securely so the diaphragm and upper and lower diaphragm washer cannot be turned on the stem. During the tightening of the upper stem nut the lower stem nut can be held in a vice, or with a second wrench.

5. Replace the gasket on the body. If an o-ring seal is used as a gasket, valve size 4" through 16", a light coating of grease can be applied to the power unit body groove to hold the o-ring in place while installing on the body. The power unit body must be replaced so that the index marks applied in Disassembly Step 1 align. The control tubing will then be able to be reassembled without difficulty.

6. Replace cover chamber spring on the upper diaphragm washer. NOTE: Some valves may not have a cover chamber spring.

7. Place the cover on the power unit body aligning the index marks. Secure the cover with 8 stud nuts. Tighten the nuts firmly with a cross-over pattern until all nuts are tight:

8. Reinstall the control system and tubing exactly as it was before disassembly.

9. The Powertrol Valve can be tested for tight closure as well as the tightness of the seal across the diaphragm.

a. The downstream or outlet shutoff valve remains closed

b. If the control system has a pilot or control that can position the valve to a closed position, put the control in a position to close the Powertrol. Lacking a control, inlet pressure must be tubed to the Powertrol cover.

c. Open upstream gate or line block valve just enough to allow flow.

d. Have the power unit body, center section, open to atmosphere. The power unit body will be atmospheric if the control is being used.

e. Partially disconnect a fitting on the discharge side of the valve. Do not remove fully unless there is no pressure.

f. After the valve is in the closed position for a few minutes, all draining of the power unit body should stop. This will indicate a good seal across the valve seat and the diaphragm.

**100-02 POWERTRON**  
VALVE SIZES 1/2" & 3/4"

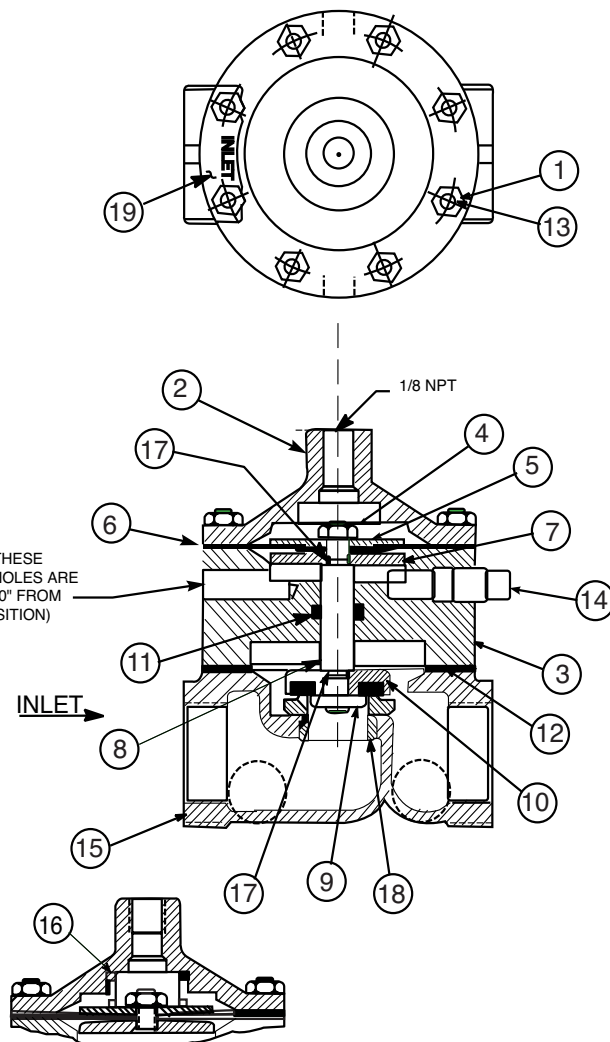

ITEM NO.	DESCRIPTION
1	HEX NUT 10-32 (8)
2	COVER
3	POWER UNIT BODY
4	HEX NUT 1/4-28-NF-2 A.S.F. JAM
5	DIAPHRAGM WASHER (UPPER)
6	DIAPHRAGM
7	DIAPHRAGM WASHER (LOWER)
8	STEM
9	DISC GUIDE
10	DISC RETAINER ASSEMBLY
11	"O" RING
12	BODY TO BODY GASKET
13	STUD 10-32 (8)
14	PIPE PLUG 1/8 NPT
15	BODY
16	SPRING (USED ON 100-02KHR & 100-02KH)
17	"O" RING
18	SEAT
19	NAMEPLATE



**USEFUL INFORMATION OR HINTS**

1. The approximate volume of liquid discharged from the chamber above the diaphragm when the valve moves from the fully closed positions to the fully open is as follows:

VALVE SIZE	DISPLACEMENT	
1/2"	0.340 Fl. Oz.	.01 Liters
3/4"	0.340 Fl. Oz.	.01 Liters
1"	0.700 Fl. Oz.	.02 Liters
1 1/4"	0.020 Gal.	.10 Liters
1 1/2"	0.020 Gal.	.10 Liters
2"	0.032 Gal.	.10 Liters
2 1/2"	0.043 Gal.	.20 Liters
3"	0.080 Gal.	.30 Liters
4"	0.169 Gal.	.60 Liters
6"	0.531 Gal.	2.00 Liters
8"	1.260 Gal.	4.75 Liters
10"	2.510 Gal.	9.50 Liters
12"	4.000 Gal.	15.14 Liters
14"	6.500 Gal.	24.60 Liters
16"	9.570 Gal.	36.20 Liters

**100-02 POWERROL  
VALVE SIZES 1" - 3"**

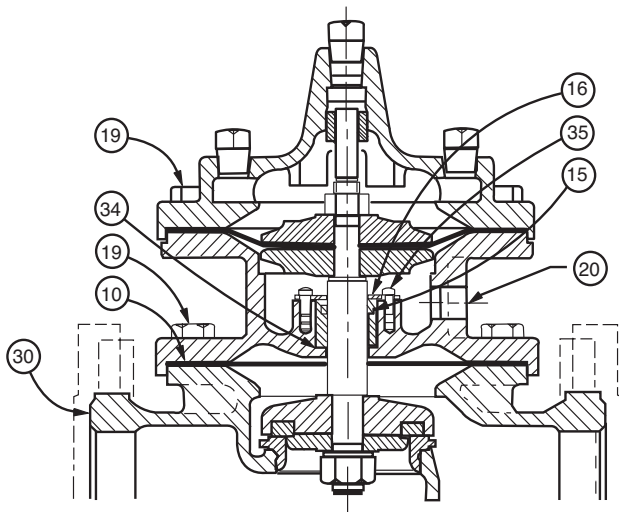
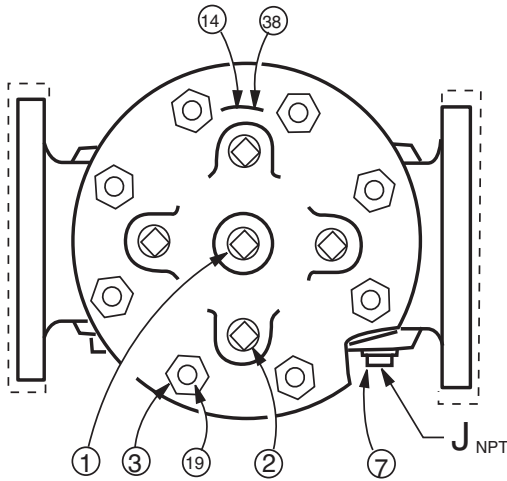

ITEM NO.	PART DESCRIPTION
1	CENTER COVER PLUG
2	COVER PLUG
3	STUD NUT
7	PLUG, PIPE, BODY
10 *	GASKET "O" RING
14	NAMEPLATE
15 *	O-RING, STEM
16	RETAINER BEARING (1"-3" ONLY)
19	BOLT, HEX HD. (1"-3" ONLY)
20	POWER UNIT BODY
21	LOWER STEM NUT
22	SPACER WASHER
24	DISC GUIDE
25	DISC RETAINER
30	BODY
31	SPRING (100-02KH/100PAKH ONLY)
32	LOCK WASHER - SPRING
33 *	SEAT O-RING
34 *	GASKET BEARING GASKET (1"-3" ONLY)
35	Screw Fil. HD. (1'-2 1/2") / BOLT HEX. (3")
36	UPPER WASHER SPRING (100PKCH)
37	LOWER WASHER SPRING (100PAKCH)
38	DRIVE SCREW

\* RECOMMENDED SPARE PARTS

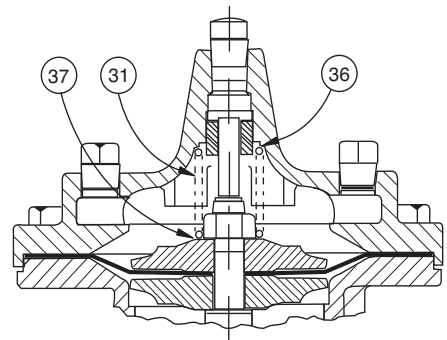

Model 100-02KH

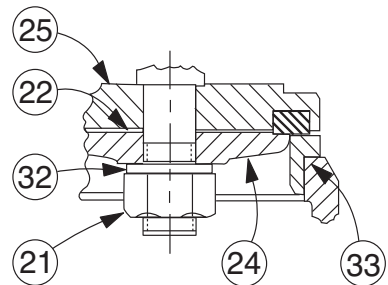

Seat & Disc Details

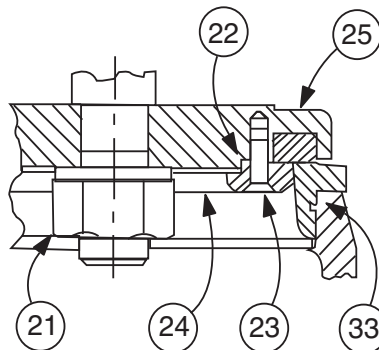
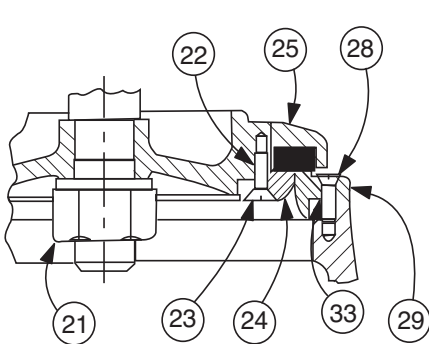
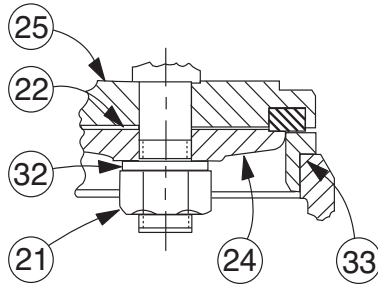
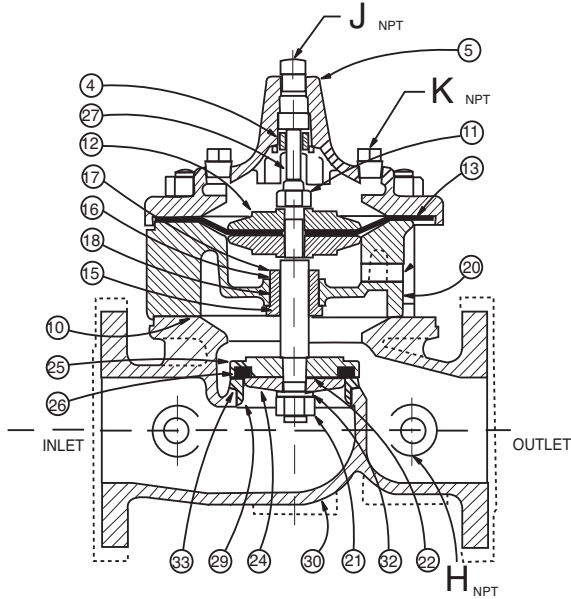
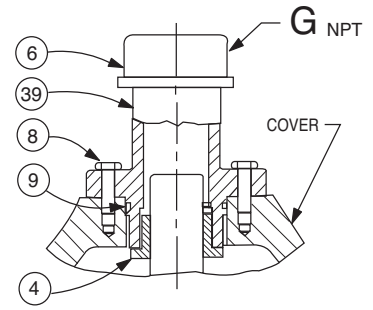
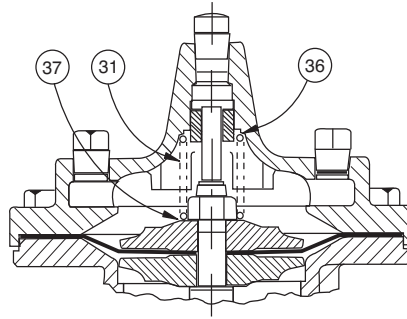
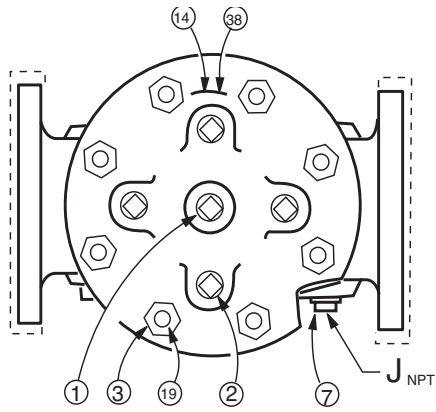

ITEM NO. PART DESCRIPTION

1	CENTER COVER PLUG
2	COVER PLUG
3	STUD NUT
4	COVER BEARING
5	COVER
6	PIPE CAP (16" ONLY)
7	PLUG, PIPE, BODY
8	BOLT HEX HD (16" ONLY)
9 *	O-RING (16" ONLY)
10 *	GASKET "O" RING
11	UPPER STEM NUT
12	UPPER DIAPHRAGM WASHER
13 *	DIAPHRAGM
14	NAMEPLATE
15 *	O-RING, STEM
16	RETAINER BEARING (1"-3" ONLY)
	RING RETAINER BEARING (4"-16" ONLY)
17	POWER UNIT BEARING
18 *	O-RING BEARING (4"-16" ONLY)
19	BOLT, HEX HD. (1"-3" ONLY)
	STUD (4"-16" ONLY)
20	POWER UNIT BODY
21	LOWER STEM NUT
22	SPACER WASHER
23	DISC GUIDE SCREW (6" - 16" ONLY)
24	DISC GUIDE
25	DISC RETAINER
26 *	DISC
27	STEM
28	SEAT SCREW (8"-16" ONLY)
29	SEAT
30	BODY
31	SPRING (100-02KH/100PAKH ONLY)
32	LOCK WASHER - SPRING
33 *	SEAT O-RING
34 *	GASKET BEARING GASKET (1"-3" ONLY)
35	Screw Fil. HD. (1'-2 1/2") / BOLT HEX. (3")
36	UPPER WASHER SPRING (100PKCH)
37	LOWER WASHER SPRING (100PAKCH)
38	DRIVE SCREW
39	COVER BEARING HOUSING (16" ONLY)

\* RECOMMENDED SPARE PARTS



— MODEL — **100-21**  
600 Series  
**Powertrol Valve**

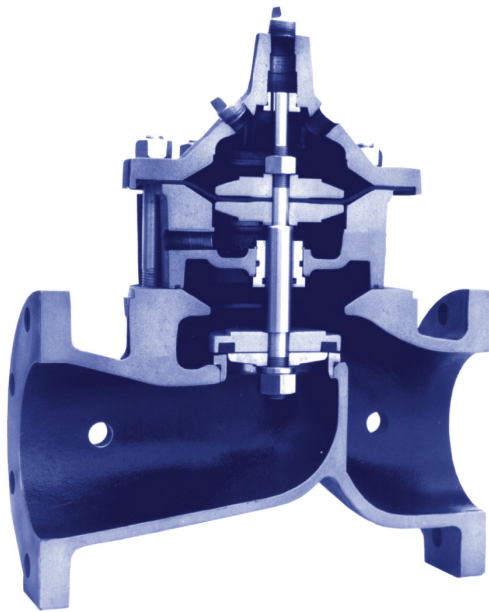

see page 2 for approvals

- **Reduced Cavitation Design**
- **Drip-tight, Positive Seating**
- **Service Without Removal From Line**
- **Globe or Angle Pattern**
- **Every Valve Factory-Tested**

The Cla-Val Model 100-21 is a hydraulically operated, diaphragm actuated, globe or angle pattern valve. It consists of four major components: the body, intermediate chamber, diaphragm assembly and cover. The diaphragm assembly is the only moving part.

The diaphragm assembly, which is guided top and center by a precision machined stem, utilizes a non-wicking diaphragm of nylon fabric bonded with synthetic rubber. The diaphragm forms a seal between the cover chamber and intermediate chamber. A synthetic rubber disc retained on three and one-half sides forms a drip-tight seal with the renewable seat when pressure is applied above the diaphragm. As pressure above the diaphragm is relieved and pressure is applied below the diaphragm, the valve opens wide for full flow. The rate of closing or opening can be controlled by modulating the pressure above or below the diaphragm.

The Model 100-21 is recommended where independent operating pressure is desired. The valve's packless construction and simplicity of design assures a long life and dependable operation. Available in various materials and in a wide range of sizes. Its applications are many and varied.

### Principle of Operation

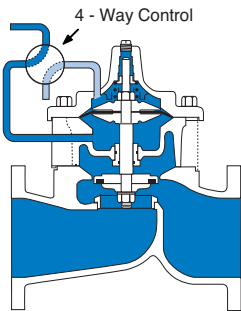

**Full Open Operation**

When operating pressure below the diaphragm is greater than the pressure in the cover chamber, the valve is held open, allowing full flow.

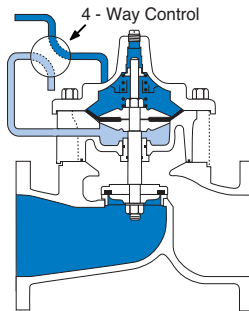

**Tight Closing Operation**

When pressure below the diaphragm is relieved and operating pressure is applied to the cover chamber, the valve closes drip-tight.

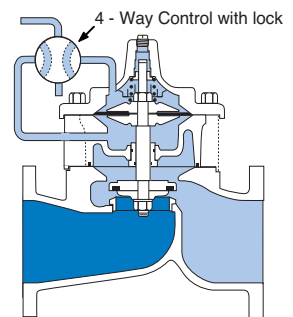

**Modulating Action**

The valve holds any intermediate position when operating pressure is equal above and below the diaphragm. A Cla-Val four-way pilot control with "lock" position can maintain this balance by stopping flow in the pilot control system.

## 100-21 Powerrol Main Valve Specifications

### Available Sizes

Pattern	Flanged
Globe (inches)	3", 4", 6", 8", 10", 12", 14", 16", 18", 20", 24", 30"
Globe (mm)	80mm - 750mm (all sizes)
Angle (inches)	4", 6", 8"
Angle (mm)	100, 150 and 200 mm

### Operating Temp. Range

Fluids
-40° to 180° F -40° to 82° C



4 1/2"/100 mm Globe, Flanged



6"/150 mm Globe, Flanged

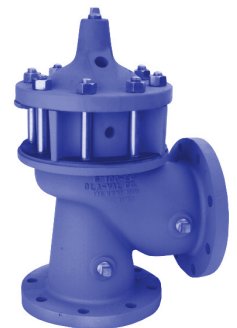

6"/150 mm Angle, Flanged

### Pressure Ratings (Recommended Maximum Pressure - psi)

Valve Body & Cover		Pressure Class		
		Flanged		
Grade	Material	ANSI Standards*	150 Class	300 Class
ASTM A536	Ductile Iron	B16.42	250	400
ASTM A216-WCB	Cast Steel	B16.5	285	400
UNS 87850	Bronze	B16.24	225	400

Note: \* ANSI standards are for flange dimensions only.  
Flanged valves are available faced but not drilled.  
**Valves for higher pressure are available; consult factory for details**

### Materials

Component	Standard Material Combinations		
Body & Cover	Ductile Iron	Cast Steel	Bronze
Available Sizes (inches)	3" - 30"	3" - 16"	3" - 16"
Available sizes (mm)	80 - 750 mm	80 - 400 mm	80 - 400 mm
Disc Retainer & Diaphragm Washer	Cast Iron	Cast Steel	Bronze
Trim: Disc Guide, Seat & Cover Bearing	Bronze is Standard Stainless Steel is optional		
Disc	Buna-N® Rubber		
Diaphragm	Nylon Reinforced Buna-N® Rubber		
Stem, Nut & Spring	Stainless Steel		

For material options on sizes not listed, consult factory.  
Cla-Val manufactures valves in more than 50 different alloys.

### Options

#### Epoxy Coating - suffix KC

An FDA approved fusion bonded epoxy coating for use with cast iron, ductile iron or steel valves. This coating is resistant to various water conditions, certain acids, chemicals, solvents and alkalies. Epoxy coatings are applied in accordance with AWWA coating specifications C116-03. Do not use with temperatures above 175°F/80° C.

#### Viton® Rubber Parts - suffix KB

Optional diaphragm, disc and o-ring fabricated with Viton® synthetic rubber. Viton® is well suited for use with mineral acids, salt solutions, chlorinated hydrocarbons, and petroleum oils; and is primarily used in high temperature applications up to 250° F/120°C. Do not use with epoxy coating above 175°F/80° C.

#### Heavy Spring - suffix KH

The heavy spring option is used in applications where there is low differential pressure across the valve, and the additional spring force is needed to help the valve close. This option is best suited for valves used in on-off (non-modulating) service.

**For assistance in selecting appropriate valve options or valves manufactured with special design requirements, please contact our Regional Sales Office or Factory.**

### Approvals



**NSF/ANSI 372: National Lead Free Mandate "Reduction of Lead in Drinking Water Act"**



**NSF International recognizes Cla-Val as complying with NSF/ANSI 61 and all applicable requirements.**

Valve Size	Inches	3	4	6	8	10	12	14	16	18	20	24	30	
	mm	80	100	150	200	250	300	350	400	460	510	610	750	
C <sub>V</sub> Factor	Globe Pattern	Gal./Min. (gpm.)	62	136	229	480	930	1458	1725	2110	2940	3400*	3500*	7900*
		Litres/Sec. (l/s.)	15	32.5	55	115	223	350	414	506	705	816	840	1895
	Angle Pattern	Gal./Min. (gpm.)	—	135	233	545	—	—	—	—	—	—	—	—
		Litres/Sec. (l/s.)	—	32	56	132	—	—	—	—	—	—	—	—
Equivalent Length of Pipe	Globe Pattern	Feet (ft.)	293	251	777	748	621	654	750	977	983	1125	3005	2130
		Meters (m.)	89.3	76.4	237.1	228.1	189.5	199.4	228.7	298.1	299.9	343.2	916.6	649.6
	Angle Pattern	Feet (ft.)	—	254	751	580	—	—	—	—	—	—	—	—
		Meters (m.)	—	77.6	229	176.9	—	—	—	—	—	—	—	—
K Factor	Globe Pattern	20.6	12.7	23.1	15.7	10.4	8.5	8.9	10.2	8.4	8.8	19.1	10.5	
	Angle Pattern	—	12.9	22.3	12.2	—	—	—	—	—	—	—	—	
Liquid Displaced from Diaphragm Chamber When Valve Opens	Fl. Oz	—	—	—	—	—	—	—	—	—	—	—	—	
	U.S. Gal.	.032	.08	.17	.53	1.26	2.51	4	4	9.6	9.6	9.6	29.0	
	ml	—	—	—	—	—	—	—	—	—	—	—	—	
	Litres	.12	.30	.64	2.0	4.8	9.5	15.1	15.1	36.2	36.2	36.2	110	

\*Estimated

**C<sub>V</sub> Factor**

Formulas for computing C<sub>V</sub> Factor, Flow (Q) and Pressure Drop (ΔP):

$$C_V = \frac{Q}{\sqrt{\Delta P}} \quad Q = C_V \sqrt{\Delta P} \quad \Delta P = \left(\frac{Q}{C_V}\right)^2$$

**K Factor (Resistance Coefficient)**

The Value of K is calculated from the formula:  $K = \frac{894d^4}{C_V^2}$  (U.S. system units)

**Equivalent Length of Pipe**

Equivalent lengths of pipe (L) are determined from the formula:  $L = \frac{Kd}{12f}$  (U.S. system units)

**Fluid Velocity**

Fluid velocity can be calculated from the following formula:  $V = \frac{.4085 Q}{d^2}$  (U.S. system units)

**Where:**

C<sub>V</sub> = U.S. (gpm) @ 1 psi differential at 60° F water  
or  
= (l/s) @ 1 bar (14.5 PSIG) differential at 15° C water

d = inside pipe diameter of Schedule 40 Steel Pipe (inches)

f = friction factor for clean, new Schedule 40 pipe (dimensionless) (from Cameron Hydraulic Data, 18th Edition, P 3-119)

K = Resistance Coefficient (calculated)

L = Equivalent Length of Pipe (feet)

Q = Flow Rate in U.S. (gpm) or (l/s)

V = Fluid Velocity (feet per second) or (meters per second)

ΔP = Pressure Drop in (psi) or (bar)

**Model 100-21 Flow Chart** (Based on normal flow through a wide open valve)

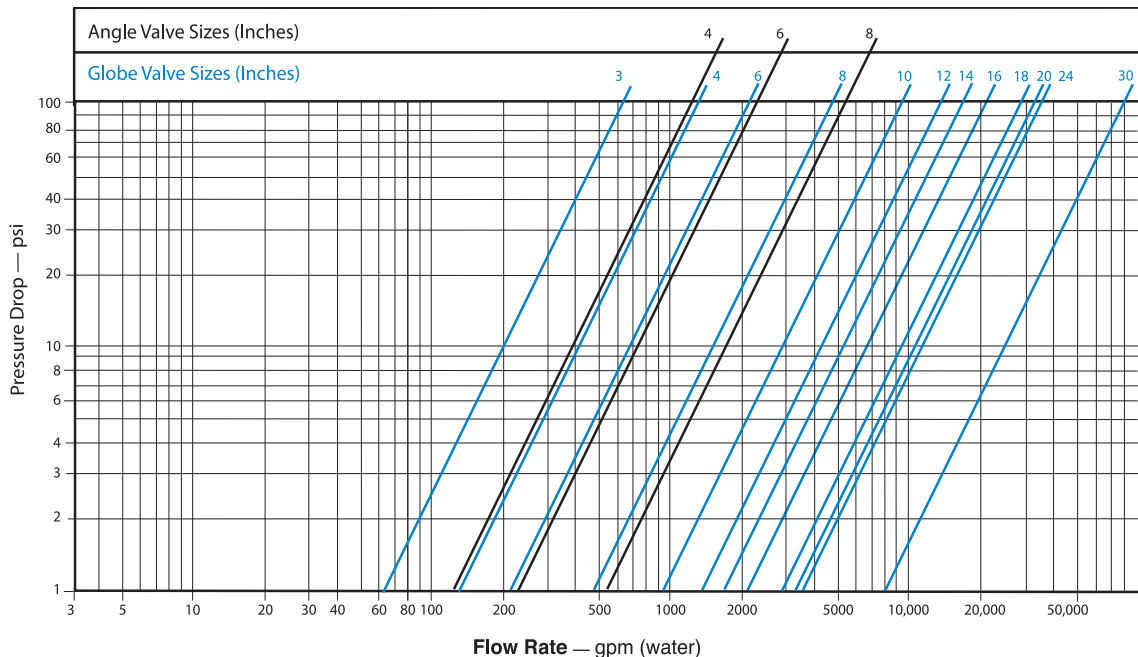

## Cla-Val 100-21 Powertrol Main Valve Dimensions

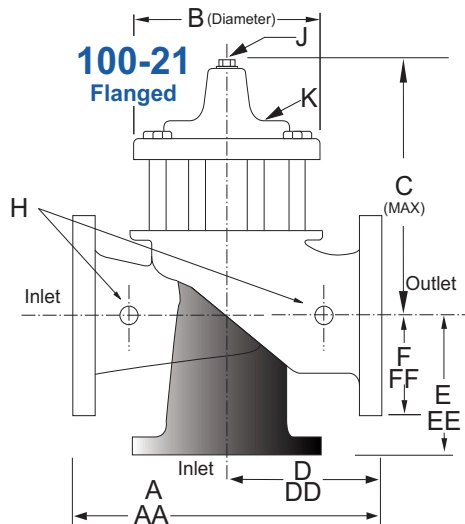

Valve Size (Inches)	3	4	6	8	10	12	14	16	18	20	24	30
A 150 ANSI	10.25	13.88	17.75	21.38	26.00	30.00	34.25	35.00	42.12	48.00	48.00	63.25
AA 300 ANSI	11.00	14.50	18.62	22.38	27.38	31.50	35.75	36.62	43.62	49.62	49.75	—
B Diameter	6.62	9.12	11.50	15.75	20.00	23.62	28.00	28.00	35.44	35.44	35.44	53.19
C Maximum	9.25	11.75	15.25	20.25	23.75	27.25	29.31	34.12	35.00	40.25	40.25	56.50
D 150 ANSI	—	6.94	8.88	10.69	—	—	—	—	—	—	—	—
DD 300 ANSI	—	7.25	9.38	11.19	—	—	—	—	—	—	—	—
E 150 ANSI	—	5.50	6.75	7.25	—	—	—	—	—	—	—	—
EE 300 ANSI	—	5.81	7.25	7.75	—	—	—	—	—	—	—	—
F 150 ANSI	3.25	4.50	5.50	6.75	8.00	9.50	11.00	11.75	15.88	14.56	17.00	19.88
FF 300 ANSI	4.12	5.00	6.25	7.50	8.75	10.25	—	12.75	15.88	16.06	19.00	—
H NPT Body Tapping	0.38	0.50	0.75	0.75	1.00	1.00	1.00	1.00	1.00	1.00	1.00	1.00
J NPT Cover Center Plug	0.50	0.50	0.75	0.75	1.00	1.00	1.25	1.25	2.00	2.00	2.00	2.00
K NPT Cover Tapping	0.38	0.50	0.75	0.75	1.00	1.00	1.00	1.00	1.00	1.00	1.00	1.00
Stem Travel	0.60	0.80	1.10	1.70	2.30	2.80	3.40	3.40	4.50	4.50	4.50	6.50
Approx. Ship Weight (lbs)	70	135	230	480	785	1410	2215	2215	2300	3400	3600	7700

Valve Size (mm)	80	100	150	200	250	300	350	400	450	500	600	750
A 150 ANSI	260	353	451	543	660	762	870	889	1070	1219	1219	1607
AA 300 ANSI	279	368	473	568	695	800	908	930	1108	1260	1264	—
B Diameter	168	232	292	400	508	600	711	711	900	900	900	1351
C Maximum	235	298	387	514	603	692	744	867	889	1022	1022	1435
D 150 ANSI	—	176	226	272	—	—	—	—	—	—	—	—
DD 300 ANSI	—	184	238	284	—	—	—	—	—	—	—	—
E 150 ANSI	—	140	171	184	—	—	—	—	—	—	—	—
EE 300 ANSI	—	148	184	197	—	—	—	—	—	—	—	—
F 150 ANSI	95	114	140	171	203	241	279	298	403	370	432	505
FF 300 ANSI	105	127	159	191	222	260	—	324	403	408	483	—
H NPT Body Tapping	0.38	0.50	0.75	0.75	1.00	1.00	1.00	1.00	1.00	1.00	1.00	1.00
J NPT Cover Center Plug	0.50	0.50	0.75	0.75	1.00	1.00	1.25	1.25	2.00	2.00	2.00	2.00
K NPT Cover Tapping	0.38	0.50	0.75	0.75	1.00	1.00	1.00	1.00	1.00	1.00	1.00	1.00
Stem Travel	15	20	28	43	58	71	86	86	86	114	114	165
Approx. Ship Weight (kgs)	32	61	104	218	356	640	1006	1006	1044	1544	1634	3496

## Service and Installation

Cla-Val Control Valves operate with maximum efficiency when mounted in horizontal piping with the main valve cover UP, however, other positions are acceptable. Due to component size and weight of 10 inch/250 mm and larger valves, installation with cover UP is advisable. We recommend isolation valves be installed on inlet and outlet for maintenance. Adequate space above and around the valve for service personnel should be considered essential. A regular maintenance program should be established based on the specific application data. However, we recommend a thorough inspection be done at least once a year. Consult factory for specific recommendations.

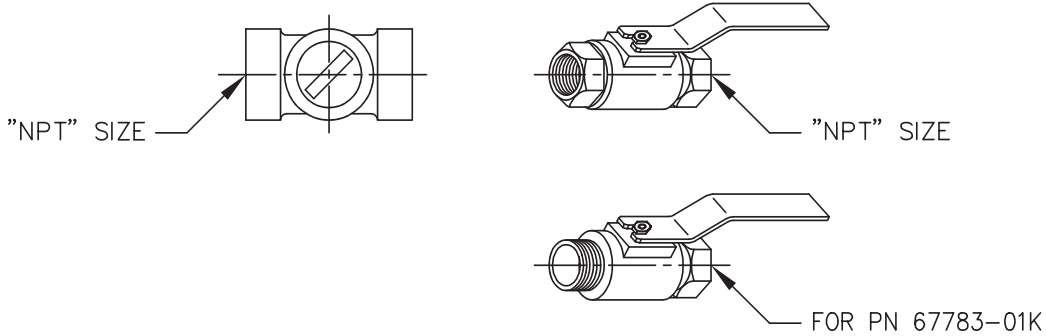

AK	07-10-08	AK	08-14-08	PC	10-1-2008			
	 <b>CLA-VAL CO.</b> NEWPORT BEACH, CALIFORNIA		CATALOG NO.		DRAWING NO. <b>67783</b>	REV <b>BD</b>		
	TYPE OF VALVE AND MAIN FEATURES  <b>CK2 COCK/BALL VALVE</b>					DESIGN DRAWN MGR 4-02-80 CHK'D KD 4-03-80 APV'D CH 4-07-80		
SCALE: NONE								
								
CLA-VAL PART NO. AND MATERIAL								
BRONZE WITH HANDLE	STEEL WITH HANDLE	IRON WITH HANDLE	316 SST WITH HANDLE	316 SST W/ LOCKING HANDLE	BRONZE WITH HANDLE	MONEL WITH HANDLE	MONEL W/ LOCKING HANDLE	SIZE "NPT"
67783-01K*	-09C	-17F	-25J SUPSD BY-26G		-41F SUPSD BY-01K			1/8"
-02H	-10A	-18D	-26G	-51E SUPSD BY-26G -52C	-42D SUPSD BY-02H	-55F		1/4"
-03F * -59H***	-11J	-19B	-27E	-46E SUPSD BY-27E -53A	-45G -57B**	-48A SUPSD BY-49J	-63K	3/8"
-04D -60F***	-12G	-20K	-28C	-54J	-43B SUPSD BY-04D	-49J	-62B	1/2"
-05A -61D***	-13E	-21H	-29A	-64H	-44K SUPSD BY-05A	-56D		3/4"
-06J	-14C	-22F	-30J			-58K		1"
-07G	-15K	-23D	-31G					1 1/4"
-08E	-16H	-24B	-32E					1 1/2"
-50G			-47C					2"
* SEE ENGINEERING APPROVED VENDORS TABLE (SHEET 2 OF 2). ** HAMMOND VALVE 8501 ONLY. *** WILKINS CK2 (SEE SHEET 2 OF 2)								

"THIS DRAWING IS THE PROPERTY OF CLA-VAL CO. AND SAME AND COPIES MADE THEREOF, IF ANY, SHALL BE RETURNED TO IT UPON DEMAND. DELIVERY AND DISCLOSURE HEREOF ARE SOLELY UPON CONDITION THAT THE SAME SHALL NOT BE USED, COPIED OR REPRODUCED, NOR SHALL THE SUBJECT HEREOF BE DISCLOSED IN ANY MANNER TO ANYONE FOR ANY PURPOSE, EXCEPT AS HEREIN AUTHORIZED, WITHOUT PRIOR WRITTEN APPROVAL OF CLA-VAL CO. THIS DRAWING IS SUBMITTED CONFIDENTIALLY AND MAY NOT BE USED IN THE MANUFACTURE OF ANY MATERIAL OR PRODUCT OTHER THAN SUCH MATERIALS AND PRODUCTS FURNISHED TO CLA-VAL CO. WHETHER OR NOT THE EQUIPMENT OR INFORMATION SHOWN HEREON IS PATENTED OR OTHERWISE PROTECTED, FULL TITLE AND COPYRIGHTS, IF ANY, IN AND TO THIS DRAWING AND/OR INFORMATION DELIVERED OR SUBMITTED ARE FULLY RESERVED CLA-VAL CO."



—MODEL— **REPAIR KITS**

**Model 100-01 Hytrol Main Valve**

BUNA-N MATERIAL				
	RUBBER KIT STOCK #	REPAIR KIT STOCK #	REBUILD ASSEMBLY STOCK #	STUD & NUT KIT STOCK #
3/8"	9169801K		21176614B	21176633J
1/2"	9169802H	21176602F	21176615A	21176634H
3/4"	9169802H	21176602F	21176615A	21176634H
1" Non-Guided	9169803F	21176601G	21176616K	21176636F
1"	9169804D	21176603E	21176617J	21176636F
1 1/4"	9169804D	21176603E	21176617J	21176636F
1 1/2"	9169804D	21176603E	21176617J	21176636F
2"	9169805A	21176608K	21176618H	21176637E
2 1/2"	9169811J	21176609J	21176619G	21176638D
3"	9169812G	21176604D	21176620D	21176639C
4"	9169813E	21176605C	21176621C	21176640K
6"	9169815K	21176606B	21176622B	21176641J
8"	9817901D	21176607A	21176623A	21176642H
10"	9817902B	21176610F	21176654C	21176643G
12"	9817903K	21176611E	21176625J	21176644F
14"	9817904H	21176612D	21176626H	21176645E
16"	9817905E	21176613C	21176627G	21176645E

**Model 100-20 Hytrol Main Valve**

BUNA-N MATERIAL				
	RUBBER KIT STOCK #	REPAIR KIT STOCK #	REBUILD ASSEMBLY STOCK #	STUD & NUT KIT STOCK #
3"	9169805A	21176608K	21176618H	21176637E
4"	9169812G	21176604D	21176620D	21176639C
6"	9169813E	21176605C	21176621C	21176640K
8"	9169815K	21176606B	21176622B	21176641J
10"	9817901D	21176607A	21176623A	21176642H
12"	9817902B	21176610F	21176624K	21176643G
14"	9817903K	21176611E	21176625J	21176644F
16"	9817903K	21176611E	21176625J	21176644F

**Model 100-30 Hytrol Main Valve**

BUNA-N MATERIAL		
	RUBBER KIT STOCK #	REBUILD ASSEMBLY STOCK #
2 1/2"	21112704H	21235401C
3"	21112702K	21235402B
4"	21112703J	21235403A
6"	27496886J	21235404K
8"	21112701A	21235405J
10"	CF	21235406H

**Rubber Kit Includes:** Diaphragm, Disc, Spacer Washers. **Model 100-30 also includes:** Stem O-Ring, Seal, Bearing O-Ring.

**Repair Kit Includes:** Diaphragm, Disc, Spacer Washers, Epoxy Coated Disc Retainer, Epoxy Coated Diaphragm Washer, Protective Washer

**Rebuild Assembly Includes:** Diaphragm, Disc, Spacer Washers, Epoxy Coated Disc Retainer, Epoxy Coated Diaphragm Washer, Protective Washer, Stainless Steel Bolts & Washers (6" & Below), Stainless Steel Studs, Nuts, & Washers (8" & Above), Stem, Stem Nut, Disc Guide, Standard Cover Spring, Cover Washer. **Model 100-30 also includes:** Upper and Lower Stem and Stem Nut, Stem O-Ring, Seal, Lower Spring, PU Bearing, Bearing O-Ring, Bearing Retainer Ring.

**Stud & Nut Kit Includes:** Stainless Steel Bolts & Washers (6" & Below), Stainless Steel Studs, Nuts, & Washers (8" & Above)



## Repair Kits for 100-02/100-21 Powertrol and 100-03/100-22 Powercheck Main Valves

**For:** Powertrol and Powercheck Main Valves—150 Pressure Class Only

**Includes:** Diaphragm, Disc (or Disc Assembly) and O-rings and full set of spare Spacer Washers.

Valve Size	Kit Stock Number 100-02	Valve Size	Kit Stock Number	
			100-02 & 100-03	100-21 & 100-22
3/8"	9169901H	2 1/2"	9169910J	N/A
1/2" & 3/4"	9169902F	3"	9169911G	9169905J
1"	9169903D	4"	9169912E	9169911G
1 1/4" & 1 1/2"	9169904B	6"	9169913C	9169912E
2"	9169905J	8"	9169950E	9169913C
		10"	9169939H	9169950E
		12"	9169937B	9169939H

Larger Sizes: Consult Factory.

## Repair Kits for 100-04/100-23 Hy-Check Main Valves

**For:** Hy-Check Main Valves—150 Pressure Class Only

**Includes:** Diaphragm, Disc and O-Rings and full set of spare Spacer Washers.

Valve Size	Kit Stock Number		Valve Size	Kit Stock Number	
	100-04	100-23		100-04	100-23
4"	20210901B	N/A	12"	20210905H	20210904J
6"	20210902A	20210901B	14"	20210906G	N/A
8"	20210903K	20210902A	16"	20210907F	20210905H
10"	20210904J	20210903K	20"	N/A	20210907F
			24"	N/A	20210907F

Larger Sizes: Consult Factory.

## Repair Kits for Pilot Control Valves (In Standard Materials Only)

**Includes:** Diaphragm, Disc (or Disc Assembly), O-Rings, Gaskets or spare Screws as appropriate.

BUNA-N® (Standard Material)				VITON (For KB Controls)	
Pilot Control	Kit Stock Number	Pilot Control	Kit Stock Number	Pilot Control	Kit Stock Number
CDB	9170006C	CFM-7A	1263901K	CDB-KB	9170012A
CDB-30	9170023H	CFM-9	12223E	CRA-KB	N/A
CDB-31	9170024F	CRA (w/bucking spring)	9170001D	CRD-KB (w/bucking spring)	9170008J
CDB-7	9170017K	CRD (w/bucking spring)	9170002B	CRL-KB	9170013J
CDH-2	18225D	CRD (no bucking spring)	9170003K	CDHS-2BKB	9170010E
CDHS-2	44607A	CRD-18	20275401K	CDHS-2FKB	9170011C
CDHS-2B	9170004H	CRD-22	98923G	CDHS-18KB (no bucking spring)	9170009G
CDHS-2F	9170005E	CRL (55F, 55L)	9170007A	102C-KB	1726202D
CDHS-3C-A2	24657K	CRL60/55L-60	9170033G		
CDHS-8A	2666901A	CRL60/55L60 1"	9170042H		
CDHS-18	9170003K	CRL-4A	43413E		
CDS-4	9170014G	CRL-5 (55B)	65755B		
CDS-5	14200A	CRL-5A (55G)	20666E		
CDS-6	20119301A	CRL-18	20309801C		
CDS-6A	20349401C	Universal CRL	9170041K		
CDS-7	20349402B	CV	9170019F		
CDS-7DO	20349403A	X105L (O-ring)	00951E		
CFCM-M1	1222301C	102B-1	1502201F	Buna-N®	
CFM-2	12223E	102C-2	1726201F	CRD Disc Ret. (Solid)	C5256H
CFM-7	1263901K	102C-3	1726201F	CRD Disc Ret. (Spring)	C5255K

## Repair Assemblies (In Standard Materials Only)

Control	Description	Stock Number
CF1-C1	Pilot Assembly Only	89541H
CF1-CI	Complete Float Control less Ball and Rod	89016A
CFC2-C1	Disc, Distributor and Seals	2674701E
CSM 11-A2-2	Mechanical Parts Assembly	97544B
CSM 11-A2-2	Pilot Assembly Only	18053K
33A 1"	Complete Internal Assembly and Seal	2036030B
33A 2"	Complete Internal Assembly and Seal	2040830J

When ordering, please give complete nameplate data of the valve and/or control being repaired. MINIMUM ORDER CHARGE APPLIES

**CLA-VAL**

1701 Placentia Ave • Costa Mesa CA 92627 Phone: 949-722-4800 • E-mail: info@cla-val.com • www.cla-val.com

© Copyright Cla-Val Printed in USA Specifications subject to change without notice.

N-RK (R-06/2022)