



# — MODEL — 60-BT Pump Control Valve with High Capacity CSM11-HC



- Built-in Check Valve
- Valve Uses Line Pressure for Operation
- Opening and Closing Rates Adjusted Separately
- Solenoid Control Can Be Operated Manually
- Can be integrated with SCADA when controlled by the UP-22D Electronic Pump Control Panel

The Cla-Val Model 60-BT Pump Control Valve is a pilot-operated valve designed for installation on the discharge of booster pumps to eliminate pipeline surges caused by the starting and stopping of the pump.

The pump starts against a closed valve. When the pump is started, the solenoid control is energized and the valve begins to open slowly, gradually increasing line pressure to full pumping head. When the pump is signaled to shut-off, the solenoid control is de-energized and the valve begins to close slowly, gradually reducing flow while the pump continues to run. When the valve is closed, a limit switch assembly, which serves as an electrical interlock between the valve and the pump, releases the pump starter and the pump stops.

Should a power failure occur, a built-in lift-type check valve closes the moment flow stops, preventing reverse flow regardless of solenoid or diaphragm assembly position.

## Schematic Diagram

Item	Description
1	100-03 Powercheck Main Valve
2	CV Flow Control
3	CSM11-HC Solenoid Control
4	X105LCW Switch Assembly
5	CVS-1 Shuttle Valve



## Optional Features

Item	Description
A	X46A Flow Clean Strainer
B	CK2 Isolation Valve
P	X141 Pressure Gauge
Y	X43 "Y" Strainer
PC-22D	Pump Control Panel

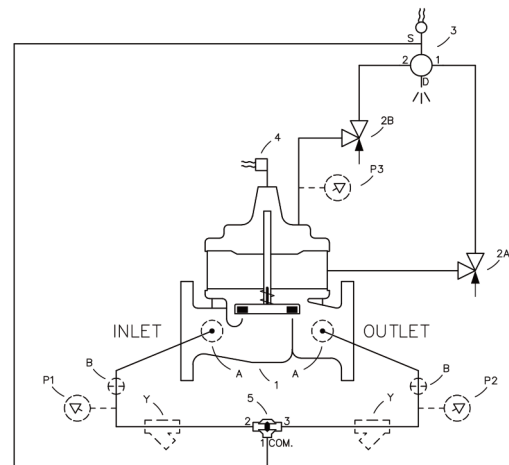

## Typical Installation

Install the valve as shown to help prevent pipelines surges during pump starting and stopping. Flexible conduit should be used for electrical connections to the solenoid control and the limit switch. A Cla-Val Model 52-03 Surge Anticipator Valve is recommended for power failure protection or the Model 652-03 if a reduced port valve is required.

Use the PC-22D Electronic Pump Control Panel for applications where electronic control and integration with SCADA is desired.

Note: Installation with valve stem vertical up is recommended. For horizontal stem installation use Cla-Val Model 60-73 or, if a reduced port valve is required, Model 660-73.

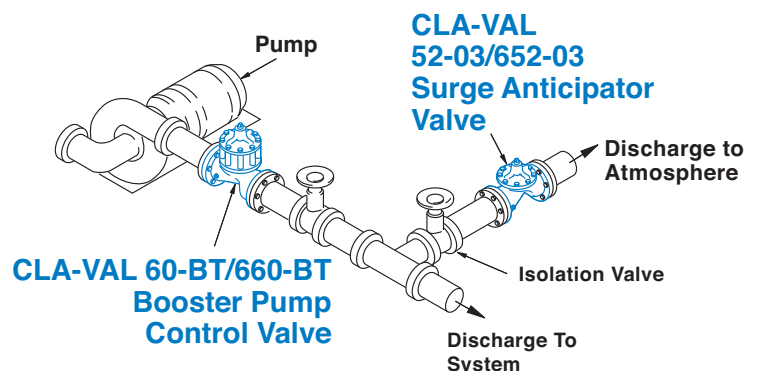

## Pressure Ratings (Recommended Maximum Pressure - psi)

Valve Body & Cover		Pressure Class			
		Flanged			Threaded
Grade	Material	ANSI Standards*	150 Class	300 Class	End† Details
ASTM A536	Ductile Iron	B16.42	250	640	400
ASTM A216-WCB	Cast Steel	B16.5	285	720	400
UNS 87850	Bronze	B16.24	225	500	400

Note: \* ANSI standards are for flange dimensions only.  
 Flanged valves are available faced but not drilled.  
 † End Details machined to ANSI B2.1 specifications.  
**Valves for higher pressure are available; consult factory for details**

## Materials

Component	Standard Material Combinations		
Body & Cover	Ductile Iron	Cast Steel	Bronze
100-03 Available Sizes	65 - 200mm	65 - 250mm	65 - 200mm
Disc Retainer & Diaphragm Washer	Cast Iron	Cast Steel	Bronze
Trim: Disc Guide, Seat & Cover Bearing	Bronze is Standard Stainless Steel is Optional		
Disc	Buna-N® Rubber		
Diaphragm	Nylon Reinforced Buna-N® Rubber		
Stem, Nut & Spring	Stainless Steel		

For material options not listed, consult factory.  
 Cla-Val manufactures valves in more than 50 different alloys.

## Model 60-BT (uses 100-03 Powercheck Main Valve)

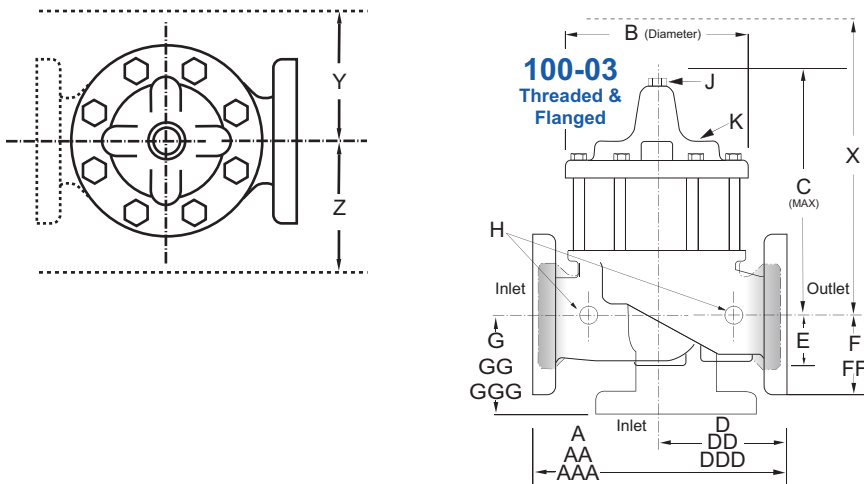

## Valve & Pilot Approvals

**NSF/ANSI 372: National Lead Free Mandate "Reduction of Lead in Drinking Water Act"**

**NSF International recognizes Cla-Val as complying with NSF/ANSI 61 and all applicable requirements.**

**Cla-Val fulfills the requirements described in the American Water Works Association's (AWWA) Standard for Pilot-Operated Control Valves: C530:12**



## 60-BT Series Dimensions (mm)

Valve Size (mm)	250	300	350	400
A Threaded	not available	not available	not available	not available
AA 150 ANSI	756	864	991	1051
AAA 300 ANSI	790	902	1029	1105
B Dia.	600	711	832	902
C Max.	594	744	816	889
D Threaded	not available	not available	not available	not available
DD 150 ANSI	378	432	495	526
DDD 300 ANSI	395	451	514	552
E	235	273	321	394
F 150 ANSI	203	241	267	298
FF 300 ANSI	222	260	292	324
G Threaded	not available	not available	not available	not available
GG 150 ANSI	219	349	378	399
GGG 300 ANSI	236	368	397	419
H NPT Body Tapping	1	1	1	1
J NPT Cover Center Plug	1	1.25	1.50	2
K NPT Cover Tapping	1	1	1	1
Stem Travel	71	86	102	114
Approx. Ship Wt. (kgs)	354	528	726	1406
X Pilot System	788	915	1016	*
Y Pilot System	559	661	737	*
Z Pilot System	559	661	737	*

60-BT Valve Selection	100-03 Pattern: Globe (G), Angle (A), End Connections: Threaded (T), Flanged (F) Indicate Available Sizes				
	Inches	10	12	14	16
	mm	250	300	350	400
Basic Valve 100-03	Pattern	G, A	G, A	G, A	G, A
	End Detail	F	F	F	F
Suggested Flow (gpm)	Maximum	4900	7000	8400	11000
	Maximum Intermittent	6150	8720	10540	13700
Suggested Flow (Liters/Sec)	Maximum	309	442	530	694
	Maximum Intermittent	387	549	664	863

**100-03 Series is the full internal port Powercheck**

## CSM11-HC Solenoid Control Power Consumption



Volts	Amperes		Coil Resistance Ohms
	Holding	Inrush	
AC 60 Hz			
24	2.88	25.4	0.5
120	.575	5.1	14.1
208	.330	2.93	40
240	.288	2.54	58
440	.156	1.38	174
440	.143	1.27	233
Volts	Amperes		Coil Resistance Ohms
	Holding	Inrush	
(AC 50 Hz)			
110	.48	4.6	15.7
220	.24	2.3	66
240	.22	2.1	88

## How to Order

### When Ordering, Specify:

1. Catalog No. 60-BT
2. Valve Size
3. Pattern - Globe or Angle
4. Pressure Class
5. Trim Material
6. Electrical Selection
7. Desired Options
8. When Vertically Installed

## CSM11-HC Specifications

Enclosure General purpose NEMA Type 3; Aluminum  
Note: For other enclosures and NEMA Types, consult factory

Housing Body — Aluminum  
Trim — Stainless Steel

Operating Pressure: Maximum pressure 300 psi, for higher pressure consult factory.

Coil Insulation Class A (molded)

AC voltage 15.4 watts

## Pilot System Specifications

### Temperature Range

Water to 180°F Max

### Materials

#### Standard Pilot System Materials

Pilot Control: Low Lead Bronze  
Trim: Stainless Steel Type 303  
Rubber: Buna-N® Synthetic Rubber

#### Optional Pilot System Materials

Pilot Systems are available with optional Aluminum, Stainless Steel or Monel materials.

## Approvals

**NSF/ANSI 372: National Lead Free Mandate "Reduction of Lead in Drinking Water Act"**

**NSF International recognizes Cla-Val as complying with NSF/ANSI 61 and all applicable requirements.**

**Cla-Val fulfills the requirements described in the American Water Works Association's (AWWA) Standard for Pilot-Operated Control Valves: C530:12**

## Wiring Diagram

Auto-Off-Hand	= Selector Switch
1CR	= Relay, DPST Normally Open
2CR	= Relay, DPST Normally Open
3CR	= Relay, TPST Normally Open
SW <sub>1</sub>	= Switch, Remote Start, Automatic
SW <sub>2</sub>	= Switch, SPDT, Valve Limit Switch Connect to N.C. Terminal
PVS	= Pilot Valve Solenoid
M	= Pump Motor Starter

Note: SW<sub>2</sub> and PVS supplied by Cla-Val. All other electrical items supplied by customer. SW<sub>2</sub> is included in the X105L switch assembly which is mounted on the pump control valve cover.

Shown In Pump Off Position

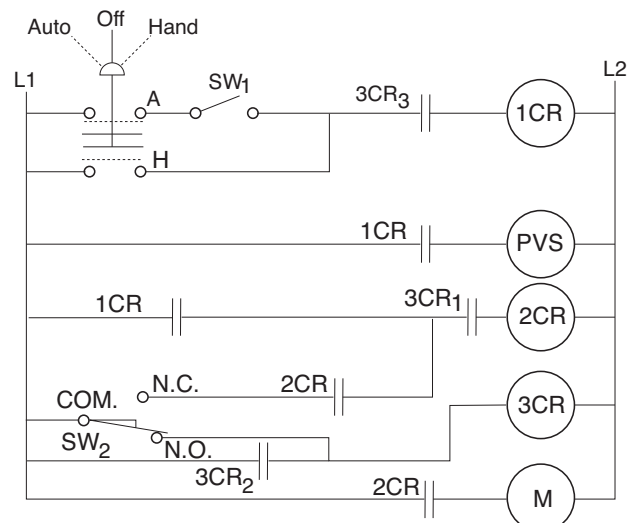

## Sequence Of Operation

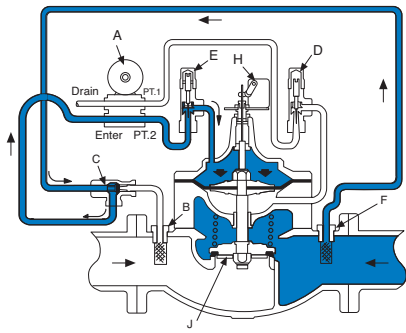

### Pump Off...

With pump off, line pressure exists above the diaphragm holding the main valve closed.

Shuttle valve C always supplies highest pressure to solenoid control A through strainers B and F.

If power failure occurs when valve is open, the built-in check valve J closes immediately to prevent reverse flow.

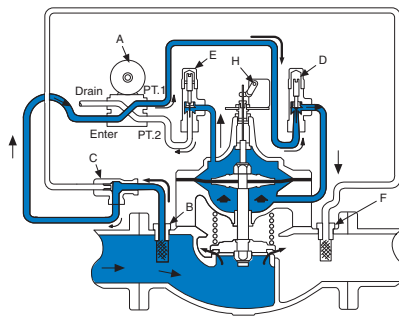

### Starting Cycle...

Starting switch closes, pump starts, solenoid control energizes.

Upstream fluid flows to chamber below main valve diaphragm through strainer B, shuttle valve C, solenoid control A, and closing rate flow control D. Valve opens slowly as fluid from diaphragm chamber is gradually released to atmosphere through opening rate flow control E and solenoid control A.

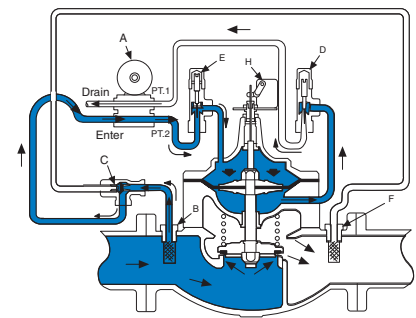

### Stopping Cycle...

Starting switch opens, solenoid control de-energizes.

Upstream fluid flows to valve diagram through strainer B, shuttle valve C, solenoid control A and opening rate Flow Control E. Valve closes slowly as fluid below diaphragm chamber is gradually released to atmosphere through closing rate flow control D and solenoid control A.

## Model 60-BT Flow Chart (Uses 100-03 Powercheck Main Valve)

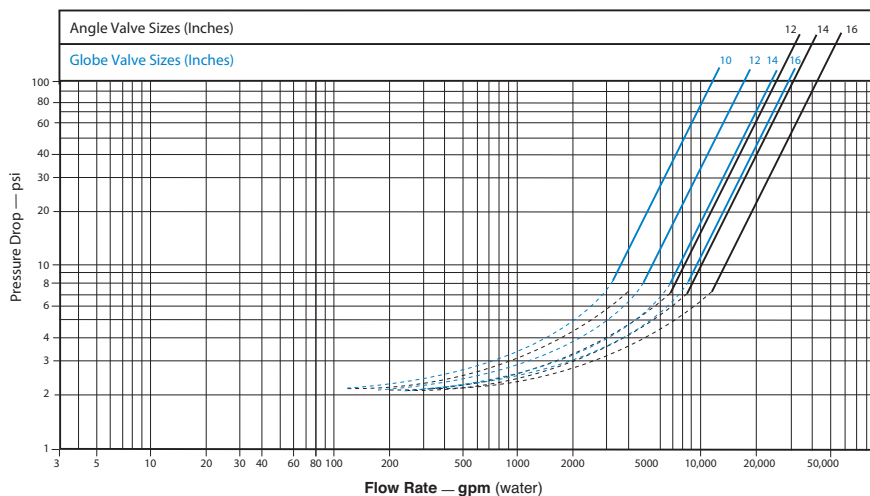

### Liquid Volume Displaced from Diaphragm Chamber When Valve Opens or Closes

Sizes (Inches)	10"	12"	14"	16"
60-BT Displacement (Liters)	9.50	15.14	24.61	36.23

## Optional Electronic Control



The Cla-Val PC-22D provides control of the pump and pump control valve, preventing surges in the system when the pump starts or stops. It consists of a pre-wired electrical control panel employing a programmable valve controller to sequence the pump and pump control valve during all modes of operation. Provides added protection to the pumping system from damage caused by mechanical, hydraulic or power failure.

The PC-22D offers all the control features found in the recommended wiring diagrams for Cla-Val pump control valves, plus alarms, automatic shutdown and adjustable timers.

## Valve Sizing

Sizing Model 60-BT Pump Control Valves is similar to sizing non-modulating type valves. Simply select the smallest size valve that will handle the pump output at an acceptable head loss for the application.

**Do not oversize.** Oversizing a Pump Control Valve will nullify its ability to prevent surges caused by the starting and/or stopping of the pump. Maximum flow values are given in the selection table above. Flow characteristics are shown on flow charts (over leaf) for these valve.

### Example:

A booster pump with a rated output of 700 gpm and 4 psi is an acceptable head loss for the application. The flow chart for the 100-03 (60-BT) indicates that a 8" globe valve has less than 4 psi pressure drop at 700 gpm.

### Drain Provisions

Each time the valve opens or closes, water is discharged from the solenoid exhaust port, the amount varying with the valve size. Provisions should be made for the disposal of this water. Exhaust tube must be free of any back pressure. Provide an air gap between the solenoid exhaust tube and drain facility.